

Top 100
Global
Innovator
for 10 years

Xmotion

Servo System



vector
Energy

LS ELECTRIC

High Performance

Intelligent control

Reliability

Convenience

Easy to use

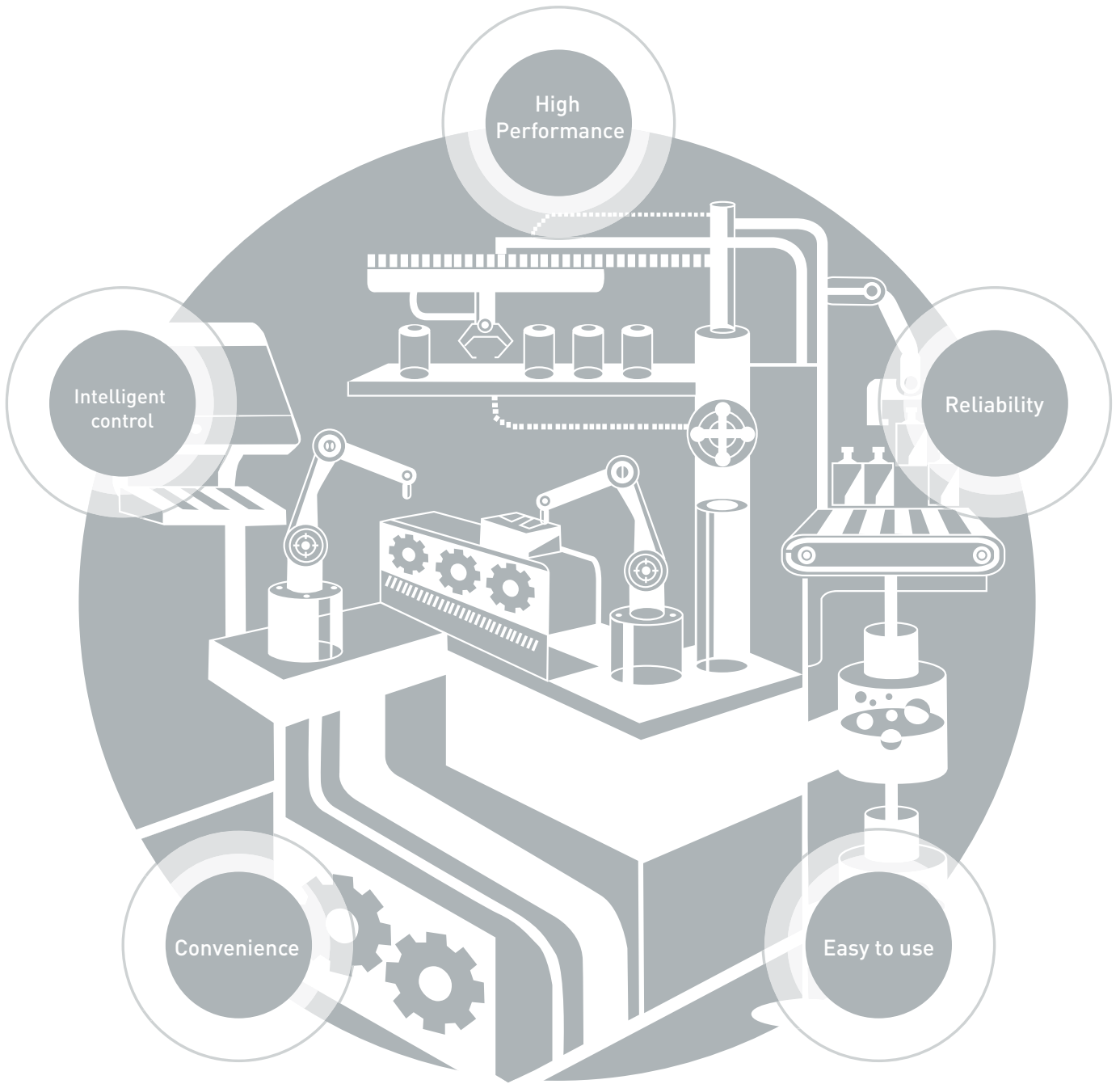

Xmotion

Servo System



Features
4 ~ 13

Features

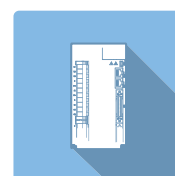

Servo Drive
14 ~ 85

Servo Drive



Servo Motor
86 ~ 139

Servo Motor

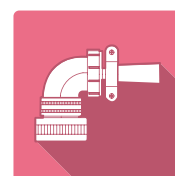

Options and Accessories
140 ~ 177

Options and Accessories

With more features and power than you ever imagined, the Xmotion Servo System is your optimal solution.



Xmotion Series

The LS Xmotion Servo System realizes your optimal solution through user-oriented features such as high-performance vector, precision, and speed control; and a diverse product line that offers the best drives suiting your extensive field applications.



Features

It's Slim

145.2mm

Minimized Width to 38mm
Increase equipment utilization
through Zero Stack application,
light weight, and miniaturization



Reliability

Improved Main Capacitor Quality

- Long-life type capacitor applied (2.5x improvement)

Convenient DC Reactor Installable

- Power connection to DC-link
- Easier wiring and smaller size compared to 3-phase AC reactor
- Connection for DC input (PI, N)

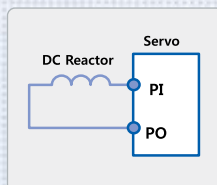

Stable Turn-off Function Based on Detection of Control Power Turn-off

Upgraded Protection Function(I)

- Triple protection functions for power module : IPM fault, CL detecting, over current detecting with S/W
- Main power mis-wiring detecting function : Selectable between 3-phase or single phase, alarm and warning available
- Overheat protection with thermal sensor in the drive and motor
- Alarm code grouping and exclusive output contacts (AL00, AL01, AL02)
- Warning function (digital output, warning output) : Mis-wiring of power, low voltage for encoder battery, over speed command, over torque command, over load, mis-matched motor and drive



Upgraded Protection Function(II)

- Supports accumulated overload detection for regenerative transistors
 - : Protect algorithm is provided with embedded resistor characteristic
 - : Protection by capacity (P0-11) and resistance (P0-10)
 - : Supports derating factor for radiant heat
- Continuous overload capacity configurable according to operating conditions
 - : Protect with separated overload table at stall & operation
 - : Overload check level customizable (P0-12)
 - : Warning signal output level customizable (P0-13)

CE, RoHS, UL Certified

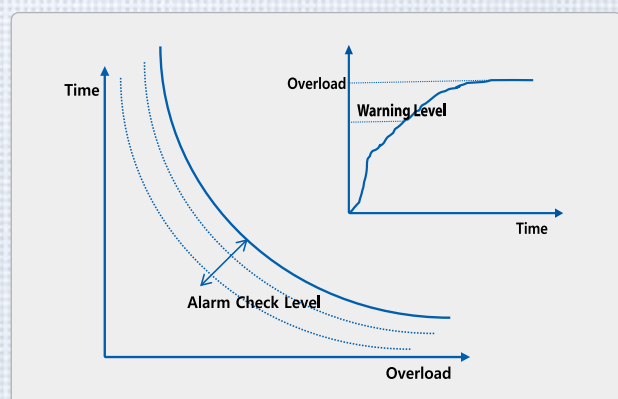

Features

Easy to USE

Complete with user-oriented manipulability and specifications optimized for the global environment, our products will become your reliable partner.



Easy Gain Tuning With Automatic Inertia Estimating Function

- Quick & Accurate Inertia Estimating
- Off-Line Tuning
- Parameter for Estimation (Speed & Distance)

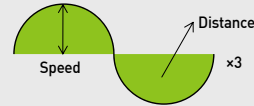

Encoder With Bi-directional High Speed Serial Communication

- Auto-recognition of motors and encoders
- BiSS protocol
- Reduced wires(7 wires) for easy wiring, noise resistant



Sufficient Input/Output Contacts and Various Functions

- iX7M: Digital input contacts : 3 (each axis) , 1 (common) / Output contacts : 2 (each axis) , 1 (common)
- iX7NH: Digital input contacts: 6, output contacts: 3 / Analog input contacts: 1 and output contacts: 2
- L7NH: Digital input contacts: 8, output contacts: 4 / Analog input contacts: 1 and output contacts: 2
- L7S: Digital input contacts: 10, output contacts: 8 / Analog input contacts: 2 and output contacts: 2
- L7C: Digital input contacts: 10, output contacts: 5 / Analog input contacts: 2 and output contacts: 0
- L7P: Digital input contacts: 16, output contacts: 8 / Analog input contacts: 2 and output contacts: 2
- PEGASUS: Digital input contacts: 4, output contacts: 2 / Analog input contacts: 1 and output contacts: 1
- Flexible assignment of input/output signals by parameters and contact setting based on the input/output contact type (N.O / N.C contacts)

Drive Node Address Configurable Through Rotary Switch [iX7NH, L7NH, L7P, PEGASUS]

- Rotary switch enables easy configuration of drive node addresses
- iX7M : 0~99, iX7NH : 0~99, L7NH : 0~99, L7P : 0~31, PEGASUS : 0~15

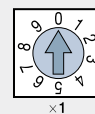
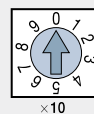

Screw-type Power Connection

- Expanded to 1kW - 3.5kW (400V) for improved wiring convenience



Various Homing Functions [iX7M, iX7NH, L7NH, L7P, PEGASUS]

- Homing function provided with each drives
- You can specify the speed, acceleration, offset, and homing method.

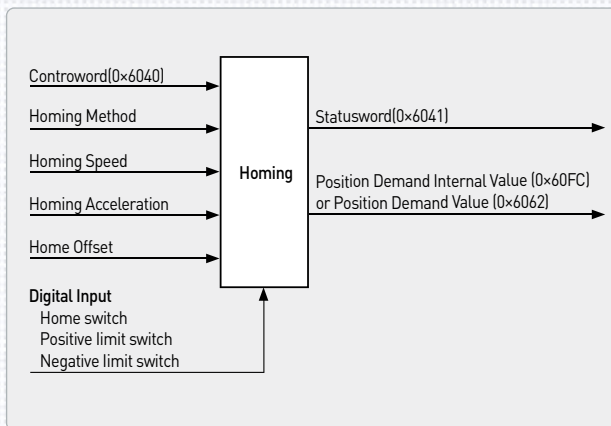

Easy Firmware Upgrade [iX7M, iX7NH, L7NH, L7P, PEGASUS]

- USB OTG enables firmware download using USB flash drives
- Useful where space is limited or environmentally unfavorable



Built-in Regenerative Braking Resistance in the Drive

- Drive installed inside to improve user convenience
- Provides connection for external installation
- Enhanced protection algorithm



Features

The Xmotion Servo is the ultimate servo system, complete with high speed, incredible performance and convenience.

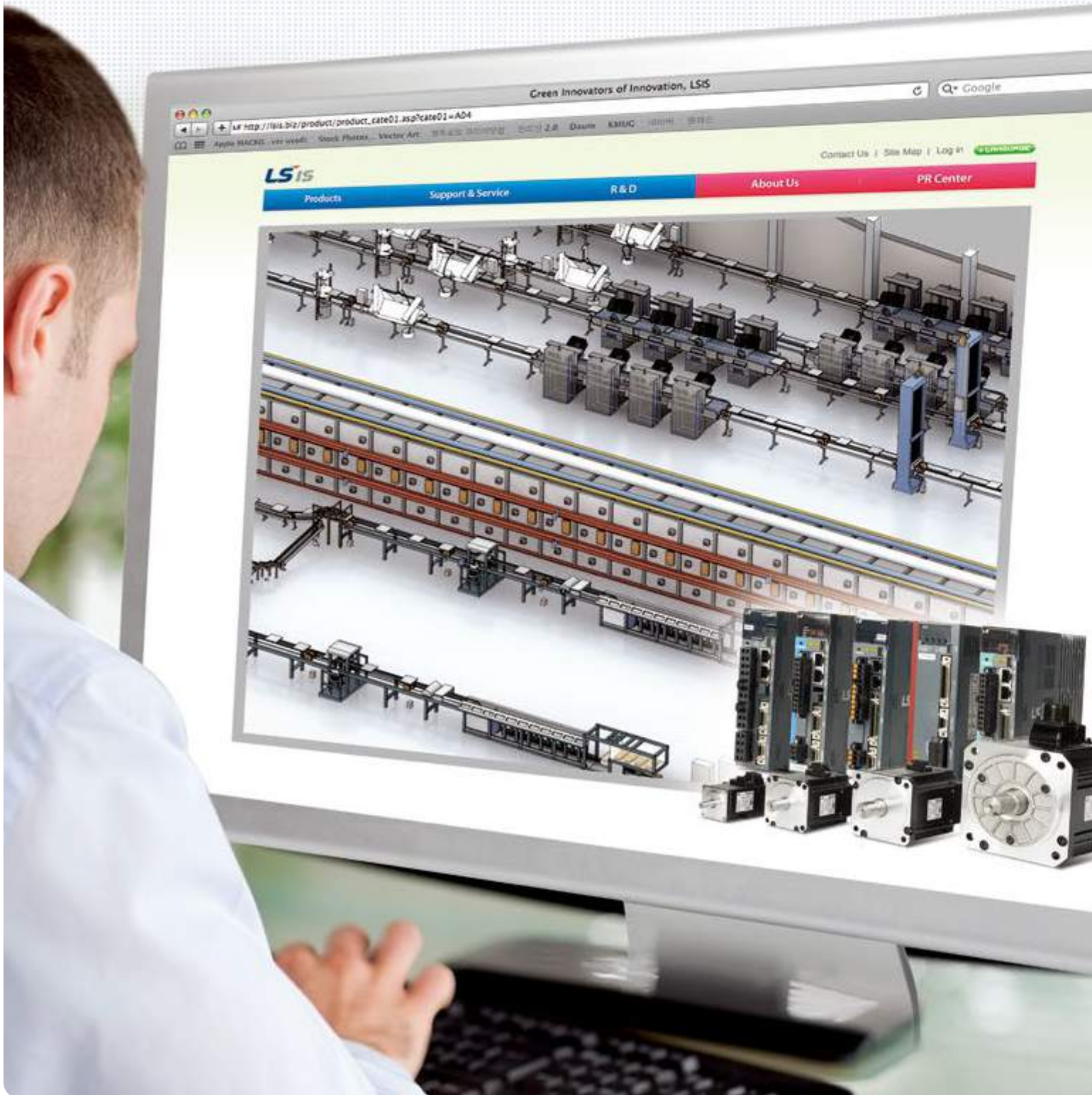

High Performance

Serial Encoder of High Resolution (16 bit - 21 bit)

- Stability improved during precision position control and low-speed operation

Stable Low-speed Properties Based on Precise Speed Measurement

- Stable speed measurement at low speed

Calculation Speed Improved [iX7M, iX7NH, L7NH, L7P, PEGASUS]

- FPU (Floating Point Unit) for reliable precision calculation
- Maximum 16kHz switching frequency for precision current control
- 32 bit operation for increased synchronous command processing rate (MIPS)

Dedicated PC Program

- L7S : LIVE-I.C.E
iX7M, iX7NH, L7NH, L7NHf, L7C, L7P, PEGASUS, PHOX : Drive CM
- PC program for shortens equipment tuning time and debugging
- Supports monitoring for speed, torque, current feedback, position values, positional error values and alarm occurrence time

Intelligent Control

Notch Filter for Resonance Suppression

- 4-step notch filter
- 2-step vibration suppression filter at the load position
- FFT function for real-time frequency analysis

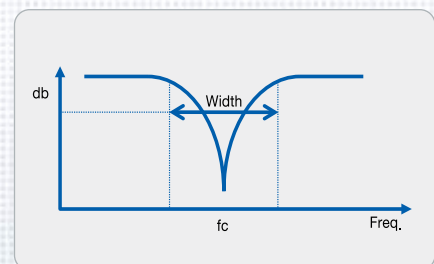

Various Gain Switching Modes for Improved Control Performance

- P/PI auto-switching function to reduce overshooting during acceleration/deceleration
- Various Gain1 ↔ Gain2 switching modes

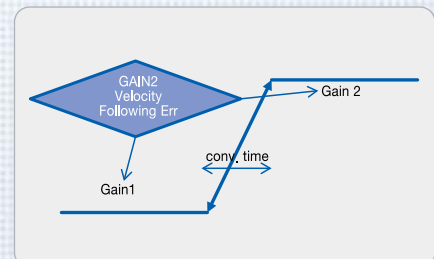

Various Dynamic Brake Control Modes

- Configurable operation mode at stop and after stop

Convenience

Our products provide differentiated customer experiences through powerful features such as backup, network diagnosis and monitoring.



High Performance

- High speed, real-time communication and synchronization mechanism

Cost Effective

- Standard Ethernet cabling and connectors, reduced cost of implementation for masters and slaves

Easy to Use

- Supports versatile topology for easy diagnostics

L7 Drive With Built-in EtherCAT Interface

- 100BASE-TX(100Mbps) Ethernet based real-time communication
- Supports CiA402(IEC61800-7) drive profile
- Supports connection with various masters and slaves
- Max. 100m between nodes
- Precise synchronization mechanism (1us)
- Freely adjustable PDO mapping
- Four status indication LEDs (L/A0, L/A1, RUN, ERR)
- Standard RJ45 connector and cabling(CAT5)
- Supports fifteen homing modes
- Support Full-closed control (L7NHF)

Various Operation Modes

- iX7NH, L7NH and PEGASUS: Uses EtherCAT communication to support Cyclic & Profile (P/S/T) modes, EOE, COE, and FOE

Safe Torque Off Function

- Torque-off forced by hardware signals without drive CPU and FPGA (ASIC) involvement; international standards adopted

High Speed Position Capture Function

- Touch probe function (PROBE1, PROBE2)

Supports Adjustment in Tandem with XGT Series

- Inertia detection, position/speed gain manual adjustment, gain switching setup, etc.

EtherCAT Drive Compatibility

- In-house test using CTT(Conformance Test Tool)

Open Network

- International standard network with over 1600 members

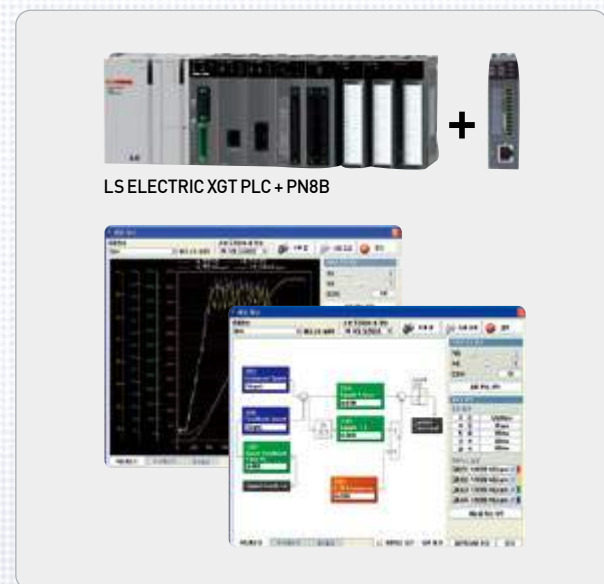
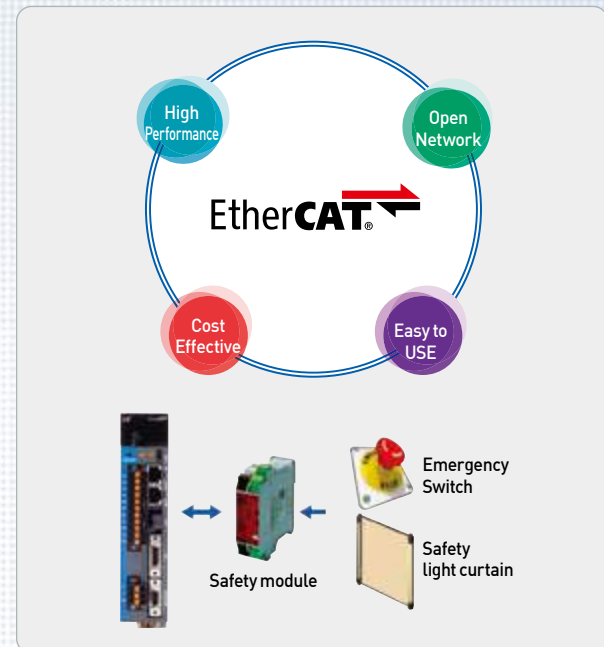

Gain Tuning Tools and Software Package Provided

- Automatic inertia tuning and PI gains
- Gain conversion setting
- Manual fine gain tuning tool
- Adjustment, saving and initialization of parameters
- Alarm history

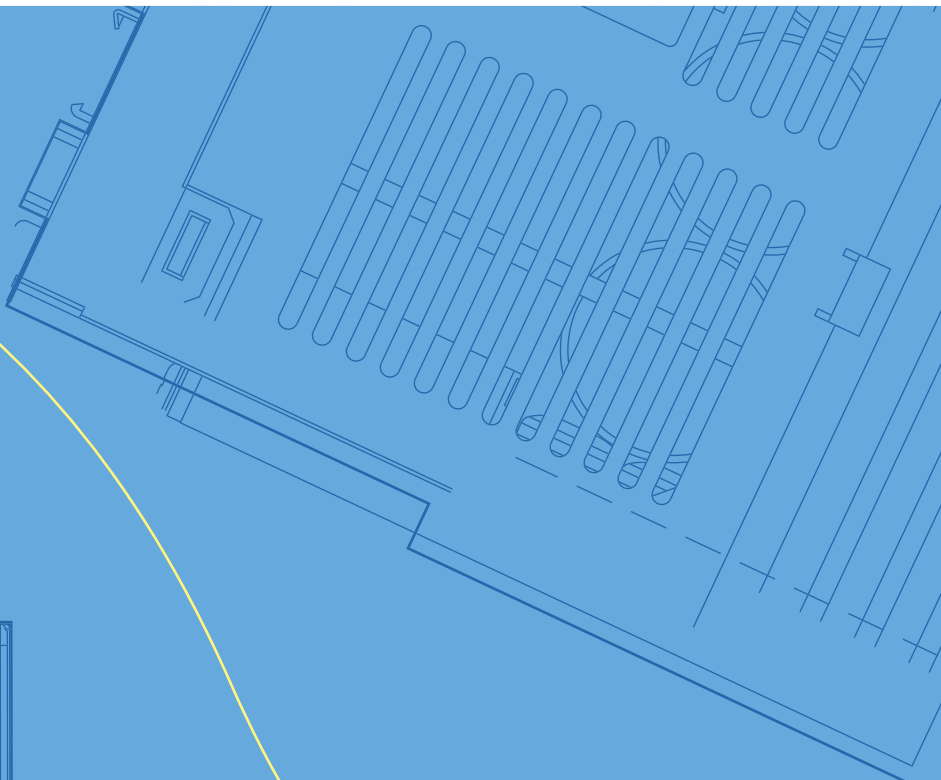
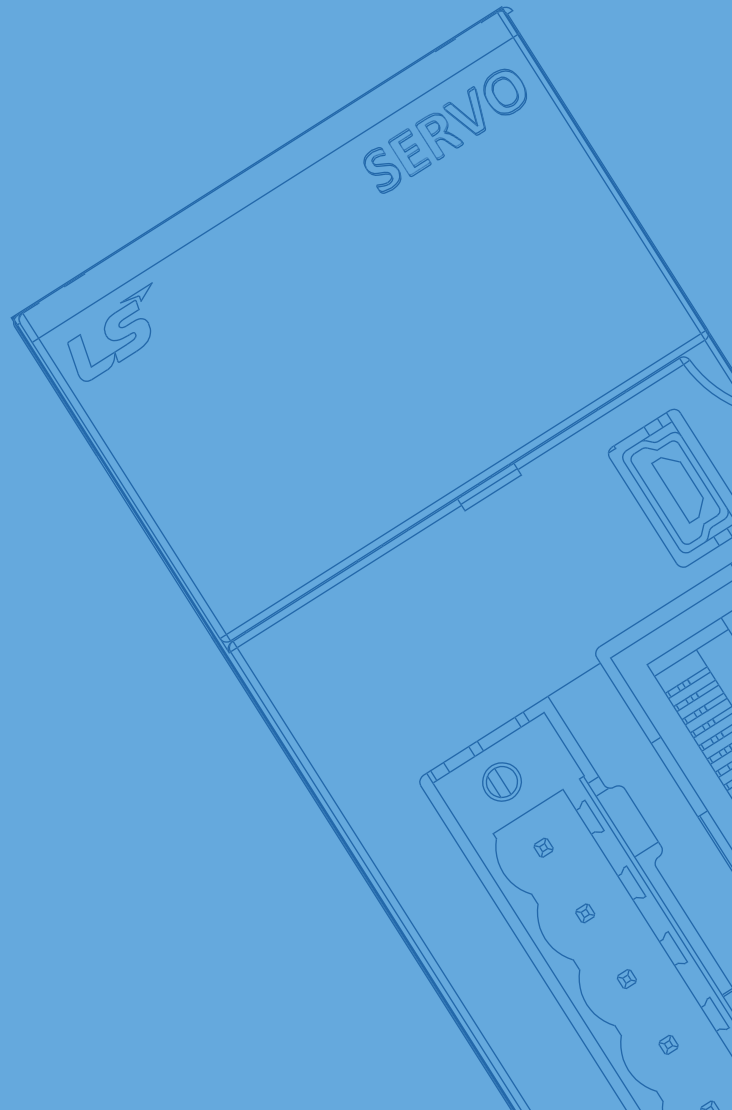
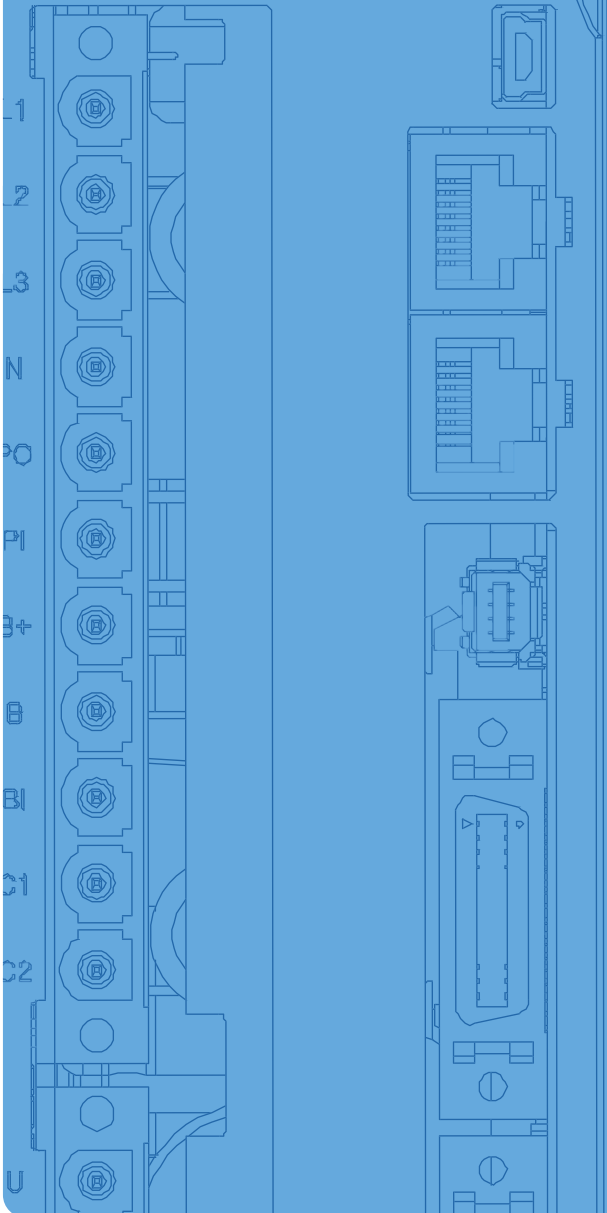
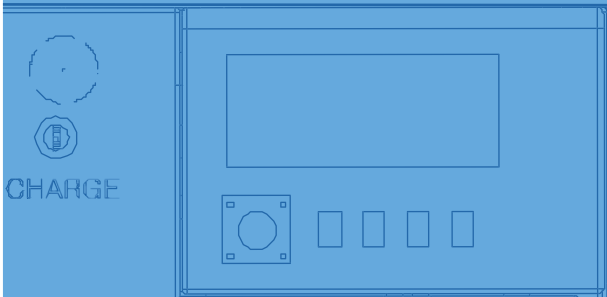

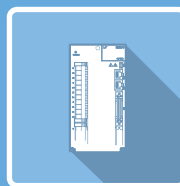

Servo Drive

Contents

iX7M Series

High-Performance Multi Purpose Servo Drive 16

iX7NH Series

Next Generation EtherCAT Network Command Type 22

L7NH Series

All-in-One EtherCAT Communication Type 28

L7NHF Series

EtherCAT Communication + Full Closed Type 38

L7S Series

Standard Pulse and Analog Command Type 44

L7C Series

Economical Pulse and Analog Command Type 54

L7P Series

Standard Pulse and Indexer Type 58

PEGA Series

Integrated Drive-Motor EtherCAT Type 66

PHOX Series

Low Voltage DC Drive Type 74

Drive Combination Table 80

iX7M Series



Servo Drive Designation

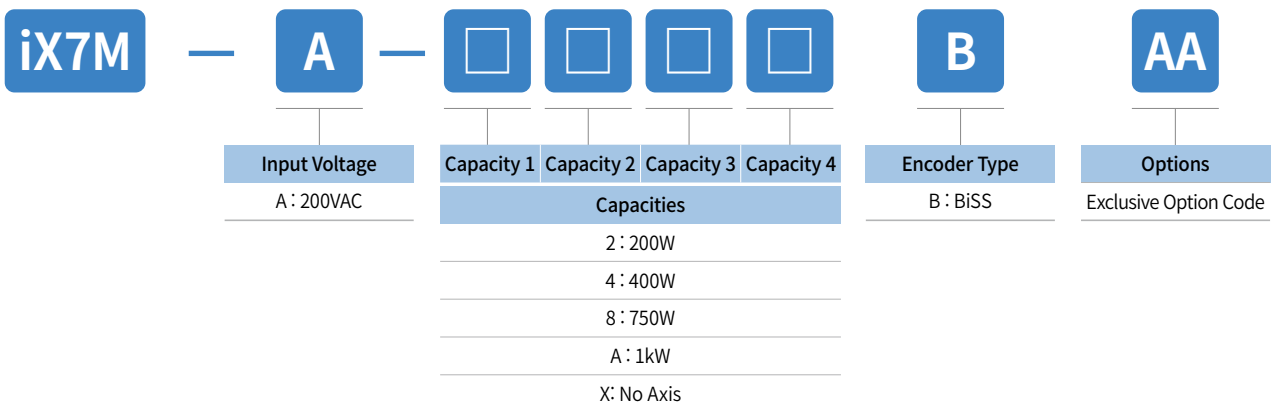

Capacity Designation

- 1. Capacities are marked on descending order
- 2. Number of digits indicate number of axes

Example)

iX7M-A-222XB ⇒ 3-axis, 200W-200W-200W
 iX7M-A-4444B ⇒ 4-axis, 400W-400W-400W-400W
 iX7M-A-AAXXB ⇒ 2-axis, 1KW-1KW

High-Performance Multi Purpose Servo Drive **iX7M**

One Servo Drive Controls Up To Four Axes

- High space efficiency and low price
- Three platforms (2-, 3- and 4-axis) provided
- Applicable to various areas, such as robot, CNC machining, 3D printing and automotive manufacturing

Minimized Installation Space & Maximized User Convenience

- Up to 40% reduced space compared to single-axis configuration
- Minimized cable wiring reduces installation space

High Precision, High Response Control Solution

- EtherCAT-based communication supports up to 125 μ s communication cycle
- Encoder supports 23-bit resolution

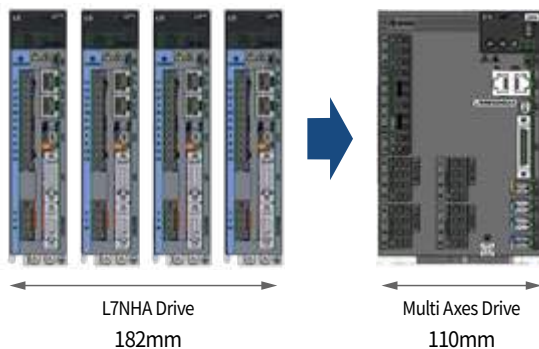

[Up to 40% reduced space]
[Compared to our L7NHA 4-axis model]

- 1 Main Power / Control Power
- 2 Motor Power (1 Axis)
- 3 Motor Power (2 Axis)
- 4 Motor Power (3 Axis)
- 5 Motor Power (4 Axis)
- 6 Fixed-type Window
- 7 USB
- 8 EtherCAT
- 9 STO
- 10 I/O
- 11 Motor Encoder (1 Axis)
- 12 Motor Encoder (2 Axis)
- 13 Motor Encoder (3 Axis)
- 14 Motor Encoder (4 Axis)
- 15 Ground Terminal (PE)

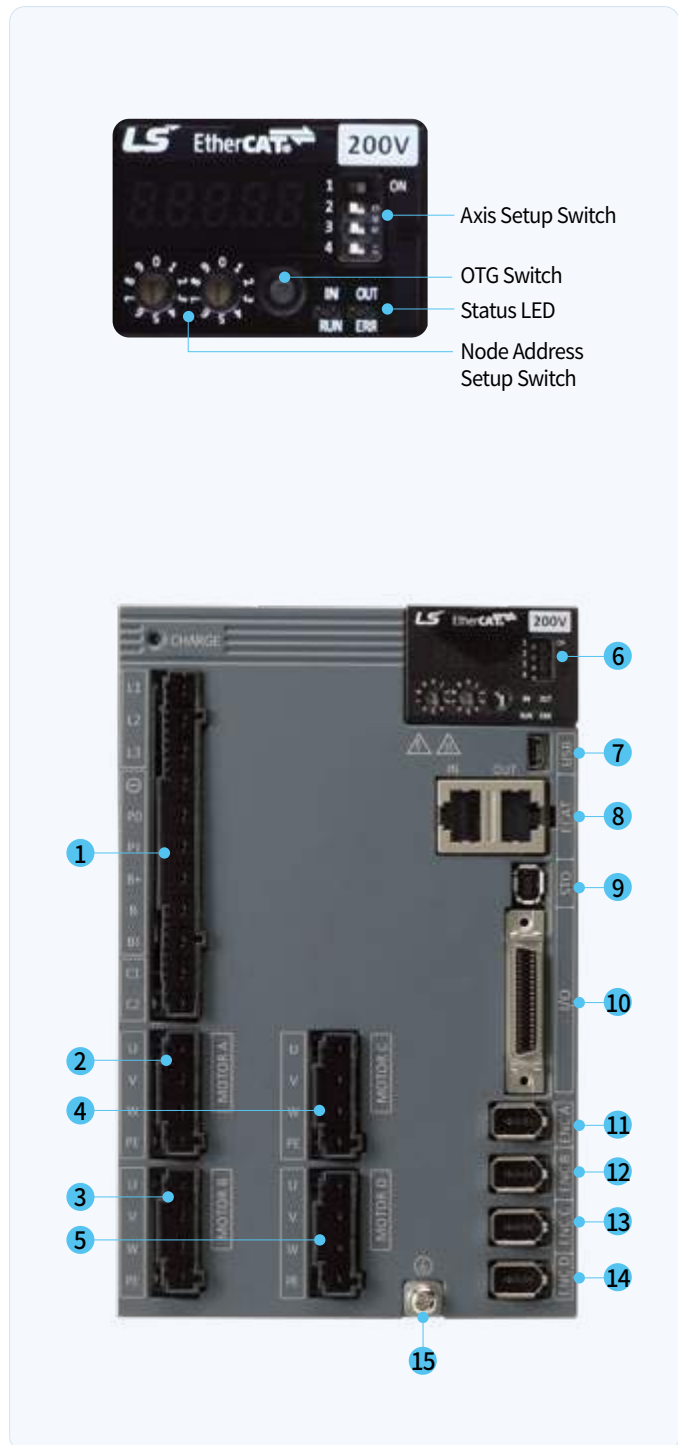

Enhanced Auto-Tuning

- ONE parameter tuning
- Vibration control
- FRF and adaptive filter (frequency detection and resonance removal)

Enhanced Connectivity

- Supports Modbus TCP
- Supports FoE
- Real-time motion library included

Enhanced Diagnosis

- Collects various predictive maintenance data
- Monitors encoder temperature
- Alarm tracing
 - Date, time and tracing data for up to 4 channels saved for alarms

New Features

- Encoder decimation output
- Diverse USB OTG features
 - Backup/restoration of drive parameters and alarm history backup

Enhanced User Convenience

- Clamp-type power connector and motor connectors for easy wiring
 - 4P motor connectors enable easy 4P wiring
- Supports PC software for status monitoring, parameter edit and OS update

Multi-Axis EtherCAT Servo Drive Product Line

Drive	Frame	Size (W×D×H)	Capacity				Specifications		
			1Axis	2Axis	3Axis	4Axis	Rated Current [Arms, Per Axis]	Max. Current [Arms, Per Axis]	Overload Rate [%]
4-Axis Drive	Frame-1	110×198×174	400W	400W	400W	400W	3	10.5	350
			200W	200W	200W	200W	1.7	5.95	350
3-Axis Drive	Frame-2	90×198×174	400W	400W	400W	-	3	10.5	350
			200W	200W	200W	-	1.7	5.95	350
2-Axis Drive (Medium Capacity)	Frame-2	90×198×174	1kW	1kW	-	-	6.75	23.62	350
			750W	750W	-	-	5.2	18.2	350
2-Axis Drive (Small Capacity)	Frame-3	70×198×174	400W	400W	-	-	3	10.5	350
			200W	200W	-	-	1.7	5.95	350

※ Please inquire if linear motors are used.

iX7M Drive

		Part Number	iX7M-A-22XXB iX7M-A-222XB iX7M-A-2222B	iX7M-A-44XXB iX7M-A-444XB iX7M-A-4444B	iX7M-A-88XXB	iX7M-A-AAXXB
Input Power	Main Power	3-Phase AC200 ~ 240[V], (-15 ~ +10[%]), 50 ~ 60[Hz]				
	Control Power	1-Phase AC200 ~ 240[V], (-15 ~ +10[%]), 50 ~ 60[Hz]				
Rated Current [A], Per Axis		1.7	3	5.2	6.75	
Max. Current [A], Per Axis		5.95	10.5	18.2	23.63	
Encoder Type		BiSS-C(Absolute, Incremental)				
Control Performance	Speed Control Range	Max. 1 : 5,000				
	Speed Variation Ratio	±0.01[%] or less (Load variation 0~100[%]), ±0.1[%] or less (temperature: 25±10[°C])				
	Torque Control Repetition Accuracy	±1[%] or less				
EtherCAT Communication	Communication Standard	FoE (firmware download) EoE (parameter setting by UDP, tuning, secondary function, parameter copy) CoE (IEC 61158 Type12, IEC 61800-7 CiA 402 Drive profile)				
	Physical Layer	100BASE-TX(IEEE802.3)				
	Connector	RJ45 x 2				
	Communication Distance	Distance between nodes 100[m] or less				
	DC (Distributed Clock)	Synchronization by DC(Distributed Clock) mode. Minimum DC cycle: 125[μs]				
	LED Display	Link Act IN, Link Act OUT, RUN, ERR				
	CiA402 Drive Profile	Profile Position Mode Profile Velocity Mode Profile Torque Mode Cyclic Synchronous Position Mode Cyclic Synchronous Velocity Mode Cyclic Synchronous Torque Mode Homing Mode				
Digital Input / Output	Digital Input	Input voltage range: DC 12[V] ~ DC 24[V] 3 input channels per axis (allocable) / 1 shared input channel (EMG fixed for all axes) Inputs of total 15 functions are selectively allocable (*POT, *NOT, *HOME, STOP, PCON, GAIN2, P_CL, N_CL, PROBE1, PROBE2, EMG, A_RST, SV_ON, LVSF1, LVSF2) <i>Note</i> *: Fundamentally allocated signals				
	Digital Output	Service rating: DC 24[V] ±10%, 40[mA] 2 output channels per axis (allocable) / 2 shared output channel (allocable) Outputs of total 11 functions are selectively allocable (*BRAKE, **ALARM, **READY, ZSPD, INPOS1, TLMT, VLMT, INPOS2, INSPD, WARN, TGOON) <i>Note</i> *: Fundamentally allocated signals, **: Default allocated signals for shared and per-axis output				
Encoder Decimation Output		Differential Line Driver 3 channels AO, /AO, BO, /BO, ZO, /ZO up to 6.5 [Mpps] on 4x interpolation on 2-axis models. Not supported on 2- or 3-axis models.				
Safety Features		2 input channels(STO1 and STO2), 1 output channel(EDM)				
USB Communication	Function	Firmware download, tuning, test drive, monitoring and parameter duplication				
	Communication Standard	Complies with USB 2.0 Full Speed and OTG 2.0 standards				
	Accessible Device	PC or USB Storage device				
Integrated Features	Dynamic Braking	Standard built-in brake (activated when the servo alarm goes off or when the servo is off)				
	Regenerative Braking	Built-in by default, external installation available				
	Display Function	7-segment display (5 digits)				
	Self-Setting Function	Drive node address setting is possible using rotary switch				
	Additional Function	Gain tuning, alarm history, jog operation, home searching				
Operation Environment	Protection Function	Overcurrent, overload, overheat, overvoltage, insufficient voltage, overspeed, abnormal state of encoder, regenerative braking error, DC fan error, position following error, current detecting error				
	Operating Temperature / Storage Temperature	0 ~ +50[°C] / -20~ +65[°C]				
	Operating Humidity / Storage Humidity	Under 90[%]RH (noncondensing)				
Environment		Keep indoors. Avoid corrosive / flammable gas or liquid.				

*Unit [mm]

**iX7M-A-22XXB /
iX7M-A-44XXB**
[Weight: 1.9kg
(With Cooling Fan)]

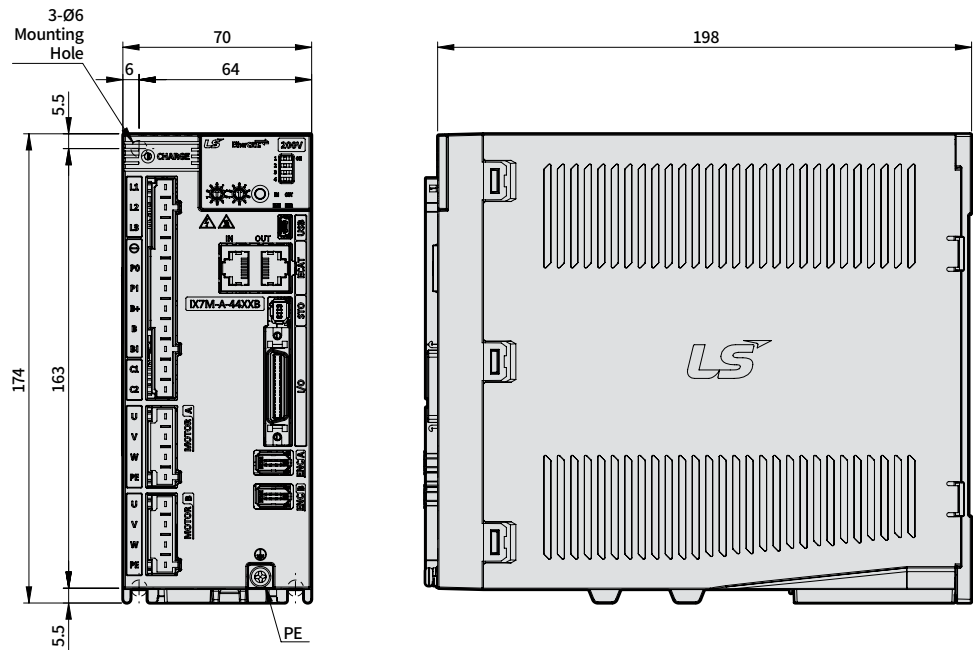

*Unit [mm]

**iX7M-A-88XXB /
iX7M-A-AAXXB**
**iX7M-A-222XB/
iX7M-A-444XB**
[Weight: 2.4kg
(With Cooling Fan)]

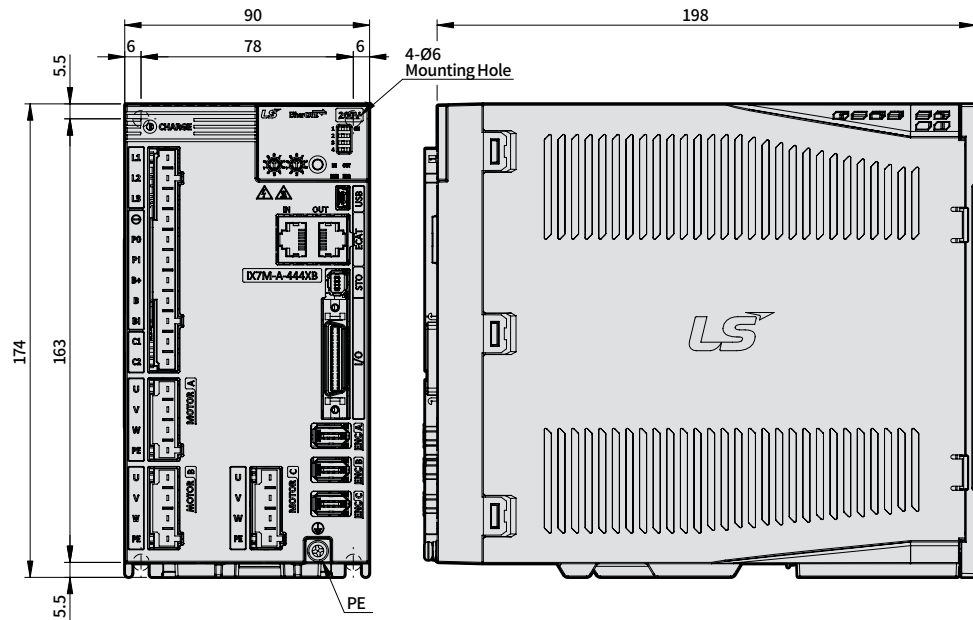

ix7NH Series



Servo Drive Designation

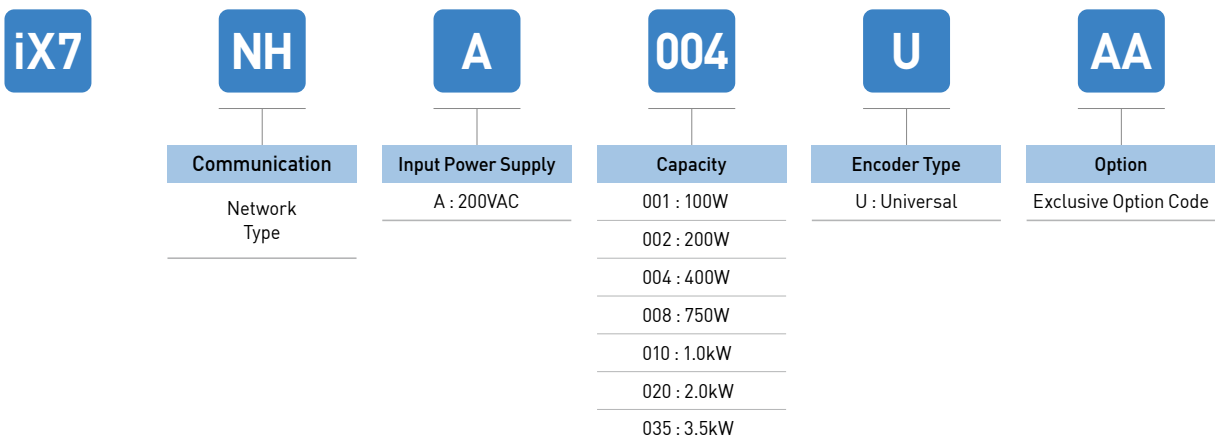

Next Generation EtherCAT Network Command Type **iX7NH**

Compact & Convenience

- Zero-stack installation space achieved through highly efficient heat dissipation
 - 100W ~ 1kW Drive
- Minimized drive depth for 100W and 200W drives through development and application of smaller heat sinks
 - 172.5mm → 145.2mm ; volume reduced by 16%
- Easy-to-open parameter display cover
- Spring clamp connector applied for easier wiring

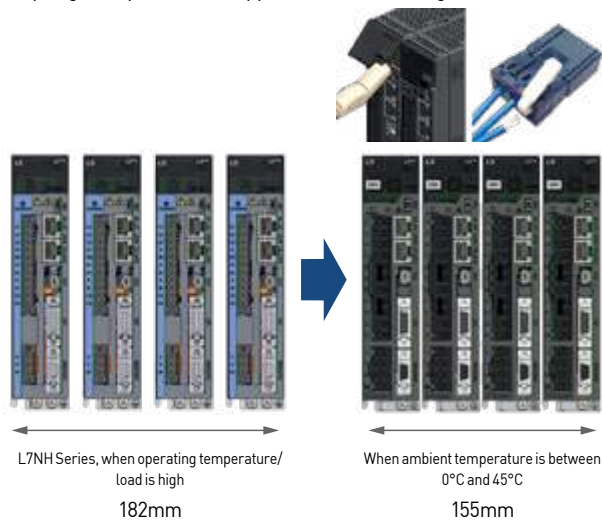

[Small-capacity Model Shown]

- 1 Display
- 2 Node address configuration switch
- 3 OTG switch
- 4 Charge indicator
- 5 Main power connector [L1, L2, L3]
- 6 DC Reactor connector [P0, PI]
- 7 Regenerative resistance connector [B+, B, BI]
 - Short-circuit B and BI terminals when using standard type
 - Use B+ and B terminals when using external resistor
- 8 Control power connector [C1, C2]
- 9 Servo motor connecting terminal [U,V,W]
- 10 Ground terminal
- 11 Connector for analog monitor
- 12 State LED
- 13 USB Connector(USB)
- 14 EtherCAT communication port(IN)
- 15 EtherCAT communication port(OUT)
- 16 Safety connector(STO)
- 17 Input/Output signal connector(I/O)
- 18 Encoder connector(ENCODER)

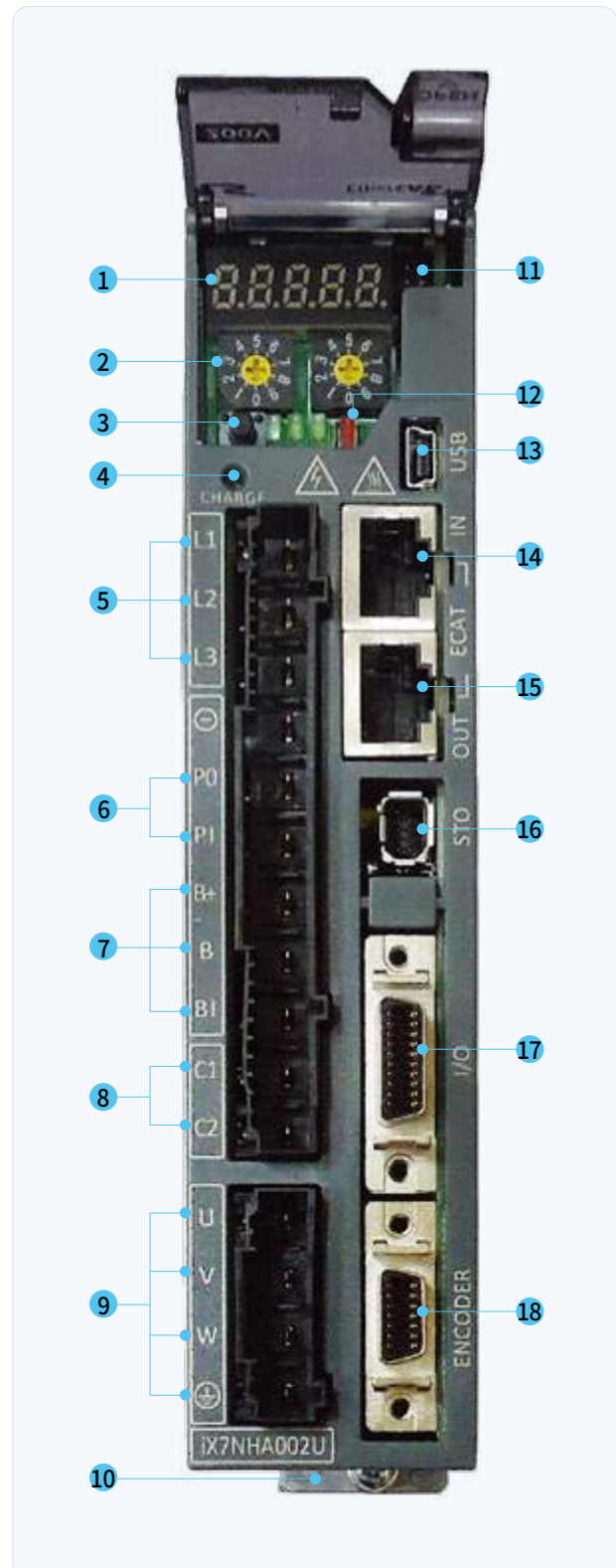

Minimized drive depth for 100W and 200W drives through development and application of smaller heat sinks

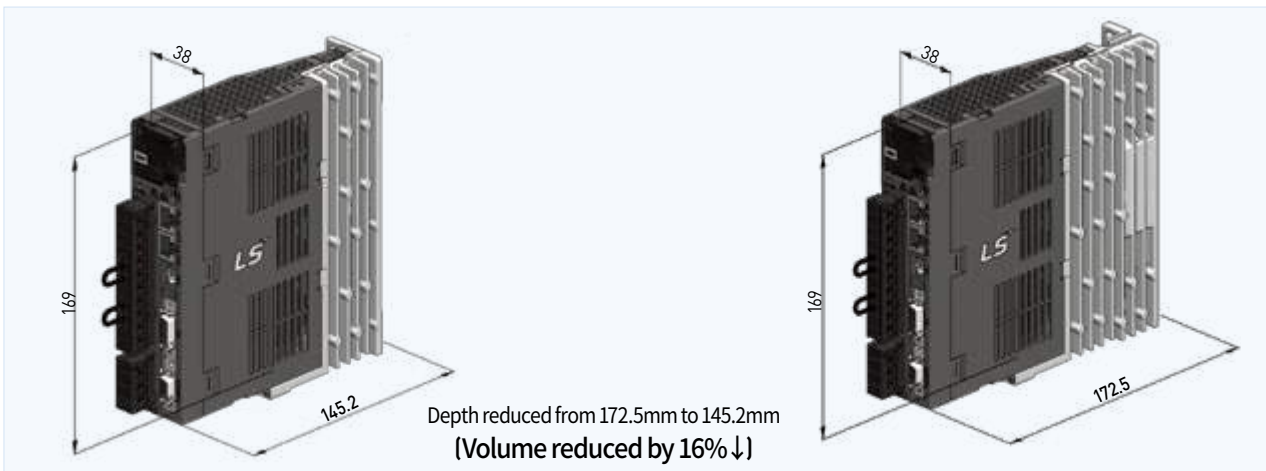

Enhanced Encoder Support & Improved Control Functionalities

- More types of encoders supported on top of high resolution encoder
 - BiSS, Quadrature, Tamagawa, Panasonic, EnDat 2.2, SSI, Nikon and Sinusoidal (Optional)
- Supports temperature monitoring through encoders
- Enhanced disconnection check function of quadrature encode
 - Disconnection check circuit added
 - No dummy wiring needed
- Improved control cycle
 - Position: 125 μ s - Speed: 62.5 μ s
 - Current: 31.25 μ s
- Enhanced alarm trace function
 - Capable of saving up to 4 maximum channels such as alarm code & alarm occurrence time/date
- Enhanced USB OTG(On-The-Go) function
 - Drive parameter backup on USB thumb drives (Drive \rightarrow USB flash drive)
 - Drive parameter restoration from USB thumb drives (Drive \leftarrow USB flash drive)
 - Drive alarm history backup (Drive \rightarrow USB flash drive)
 - Firmware update (Drive \leftarrow USB flash drive)
 - Added buttons for user convenience

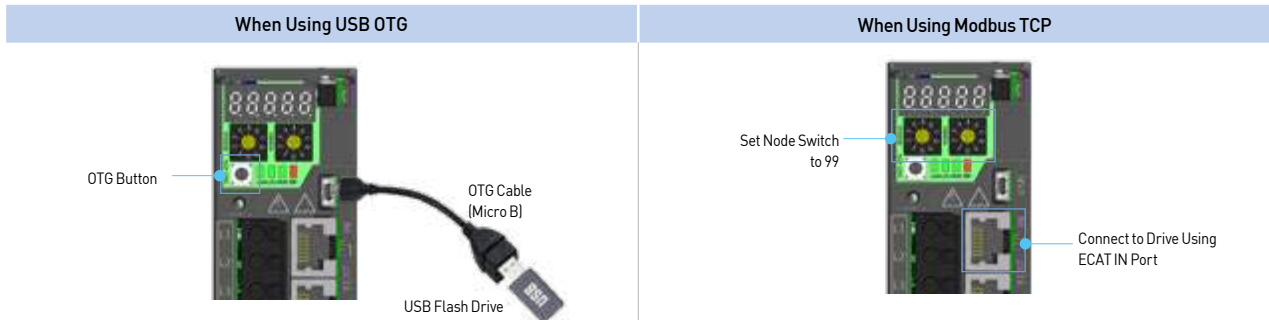

Faster Communication Provided in More Diverse Methods

- Fieldbus Supported: EtherCAT & Modbus TCP
- Min. Communication Cycle Time: 0.125ms
- Advanced EtherCAT functionality
 - Minimum communication cycle time improved to 0.125 ms from 0.250 ms
 - FoE function supported
- Built-in web server function
 - With web server embedded in servo drive, no drive CM (Configuration software) is needed other than web browser environment
 - Enhanced remote commissioning function through Ethernet connection



iX7NHA Drive

Item		Part Number	iX7NHA001U	iX7NHA002U	iX7NHA004U	iX7NHA008U	iX7NHA010U	iX7NHA020U	iX7NHA035U
Input Power	Main Power		1-Phase AC100 ~ 120[V], 1-Phase AC200 ~ 240[V], 3-Phase AC200 ~ 240[V], [-15 ~ +10[%]], 50 ~ 60[Hz]			1-Phase AC200 ~ 240[V], 3-Phase AC200 ~ 240[V], [-15 ~ +10[%]], 50 ~ 60[Hz]	3-Phase AC200 ~ 240[V], [-15 ~ +10[%]], 50 ~ 60[Hz]		
	Control Power		1-Phase AC100 ~ 120[V] 1-Phase AC200 ~ 240[V] [-15 ~ +10[10%]], 50 ~ 60[Hz]			1-Phase AC200 ~ 240[V] [-15 ~ +10[10%]], 50 ~ 60[Hz]			
Rated Current [A]			1.4	1.7	3.0	5.2	6.75	13.5	16.0
Peak Current [A]			4.9	5.95	10.5	18.2	20.25	40.5	48.0
Encoder Type			Quadrature (Incremental) , BiSS-B, BiSS-C(Absolute, Incremental) Tamagawa Serial(Absolute, Incremental), EnDat 2.2, Sinusoidal, Analog Hall, SSI, Nikon, Panasonic						
Control Performance	Speed Control Range		Max. 1 : 5000						
	Speed Variation Ratio		±0.01[%] or less (Load variation 0~100[%]), ±0.1[%] or less (temperature: 25±10[°C])						
	Torque Control Repetition Accuracy		±1[%] or less						
EtherCAT Specification	Communication Standard		FoE (Firmware download) EoE (Parameter setting by UDP, Tuning, Secondary function, Parameter copy) CoE (IEC 61158 Type12, IEC 61800-7 CiA 402 Drive profile)						
	Physical Layer		100BASE-TX(IEEE802.3)						
	Connector		RJ45 x 2						
	Communication Distance		Distance between nodes 100[m] or less						
	DC (Distributed Clock)		Synchronization by DC(Distributed Clock) mode. Minimum DC cycle: 125[us]						
	LED Display		Link Act IN, Link Act OUT, RUN, ERR						
	CiA 402 Drive Profile		Profile Position Mode, Profile Velocity Mode, Profile Torque Mode, Cyclic Synchronous Position Mode Cyclic Synchronous Velocity Mode, Cyclic Synchronous Torque Mode, Homing Mode						
Digital Input, Digital Output	Digital Input		Input Voltage range: DC 12[V] ~ DC 24[V] / Total 6 input channels (allocable) Inputs of total 15 functions are selectively allocable (*POT, *NOT, *HOME, *STOP, *PCON, *GAIN2, P_CL, N_CL, PROBE1, PROBE2, EMG, A_RST, SV_ON, LVSF1, LVSF2) Note) *: Fundamentally allocated signals						
	Digital Output		Service rating: DC 24[V] ±10%, 120[mA] total 3 channels (allocable) Total 11 outputs are selectively allocable (*BRAKE, *ALARM, *READY, ZSPD, INPOS, TLMT, VLMT, INPOS2, INSPD, WARN, TGON) Note)* Automatically allocated signals						
Encoder Decimation Output			Differential Line Driver 3 channels AO, /AO, BO, /BO, ZO, /ZO up to 6.5 [Mpps] on 4x interpolation						
Analog Input & Output	Analog Input		Input voltage range: -10 ~ +10[V], Function: analog torque limit (1 channel, unallocable)						
	Analog Output		Total 2 channels (Allocable): able to selectively allocate total 25 types of output						
Safety Function			2 Input Channels(STO1 and STO2), 1 Output Channel(EDM)						
USB Communication	Function		Firmware download, tuning, test drive, monitoring, parameter duplication						
	Communication Standard		Complies with USB 2.0 Full Speed and OTG 2.0 standards						
	Accessible Device		PC or USB Storage device						
Embedded Function	Dynamic Braking		Standard built-in brake (Activated when the servo alarm goes off or when the servo is off).						
	Regenerative Braking		Built-in by default (100W & 200W excluded)						
	Display Function		7-segment display (5 digits)						
	Self-setting Function		Drive node address setting is possible using rotary switch						
	Additional Function		Gain tuning, alarm history, jog operation, home searching						
Protection Function			Overcurrent, overload, overheat, overvoltage, insufficient voltage, overspeed, abnormal state of encoder, position following error, current detecting error						
Operation Environment	Operating Temperature / Storage Temperature		0 ~ +50[°C] / -20 ~ +65[°C]						
	Operating Humidity / Storage Humidity		Under 80[%]RH / Under 90[%]RH (noncondensing)						
	Environment		Keep indoors. Avoid corrosive / flammable gas or liquid.						

*Unit [mm]

iX7NHA001U / iX7NHA002U
[Weight : 0.8kg]

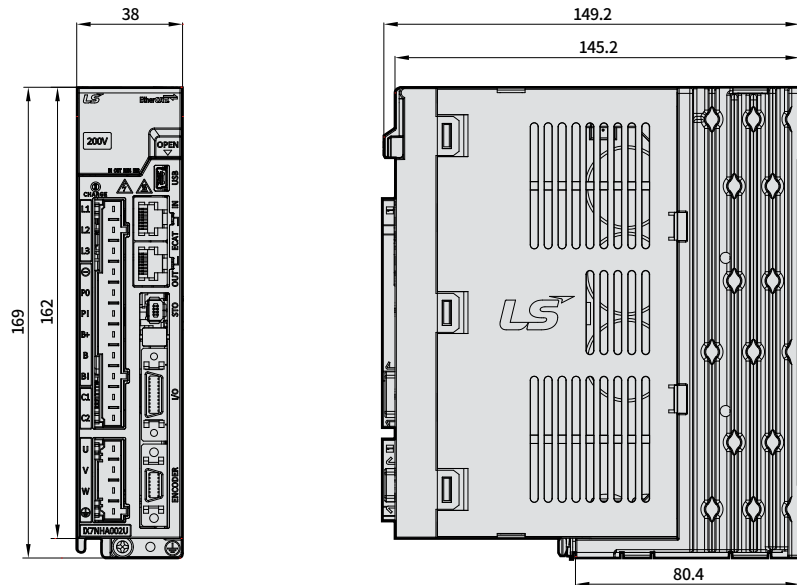

*Unit [mm]

iX7NHA004U
[Weight : 1.0kg]

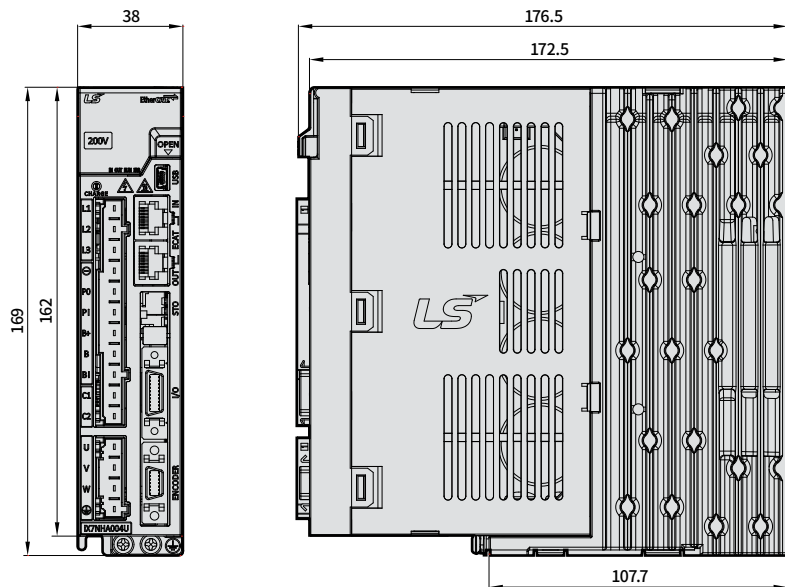

*Unit [mm]

ix7NHA008U / ix7NHA010U

[Weight : 1.6kg
[Fan-Cooling included]]

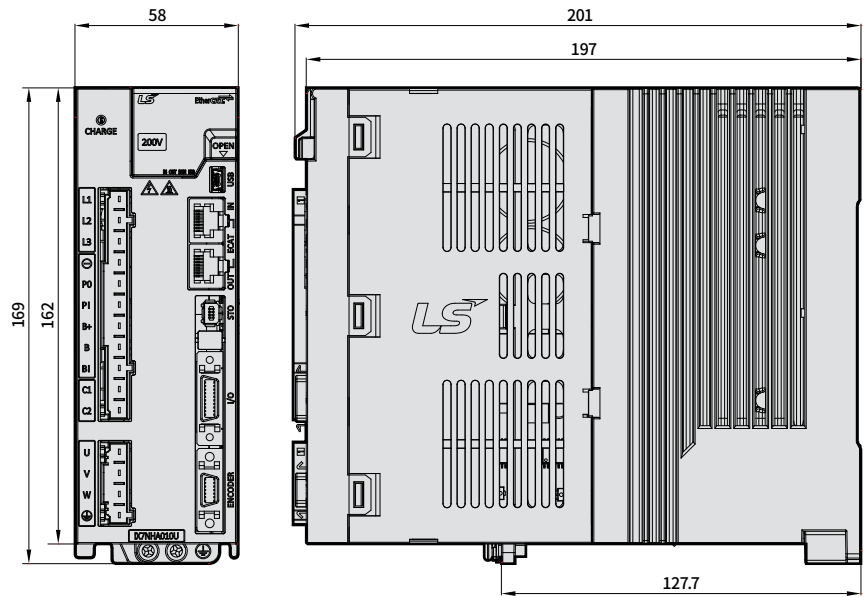

*Unit [mm]

ix7NHA020U / ix7NHA035U

[Weight : 2.4kg
[Fan-Cooling included]]

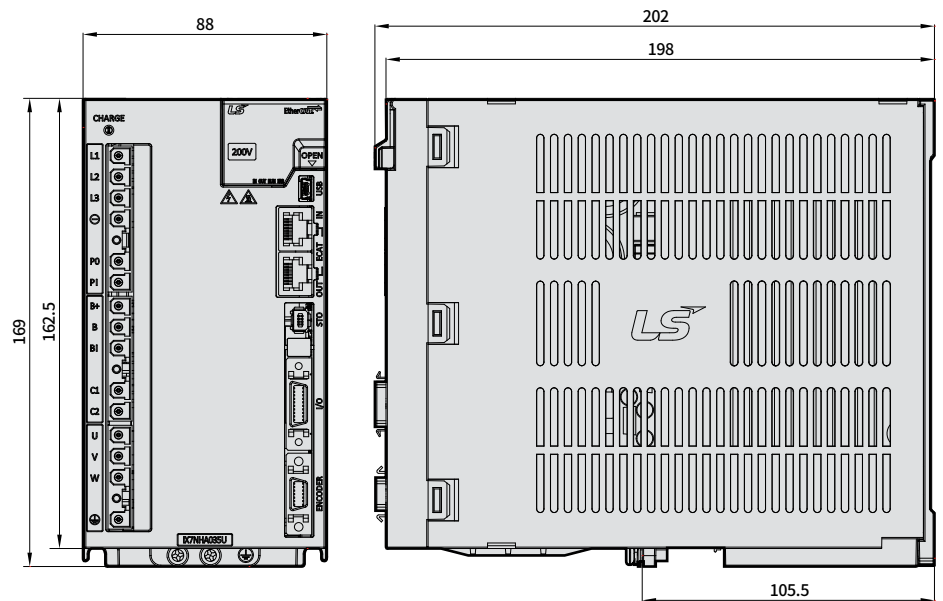

L7NH Series



Servo Drive Designation

L7	NH	A	004	U	AA
Communication	Input Power Supply	Capacity	Encoder Type	Option	
Network Type	A : 200VAC B : 400VAC	001 : 100W 002 : 200W 004 : 400W 008 : 750W 010 : 1.0kW 020 : 2.0kW 035 : 3.5kW 050 : 5.0kW 075 : 7.5kW 150 : 15kW	U : Universal	Exclusive Option Code	

EtherCAT Communication Type **L7NH**

Real-time Control Through EtherCAT

- High speed, Real-time capability and Synchronization mechanism
- Improved EtherCAT communication speed (min. 250µs, DC support)
- Supports CoE, EoE and FoE
- Improved frequency response(≈1kHz)

Compatible with Various Motors and Encoders

- Operates with rotary, DD and linear motors (3rd-party motors supported)
- Quadrature, BiSS-C, Tamagawa serial abs, EnDat 2.2, Panasonic serial abs, Sinusoidal

Improved Control Performance

- Improved control bandwidth
- 4-step notch filter provided
- Vibration control by Real-time FET
- Real-time gain tuning function

- 1 Display
- 2 State LED
- 3 Charge indicator
- 4 Main power connector (L1, L2, L3)
- 5 DC Reactor connector (PO, PI)
 - Short-circuit when not in use
- 6 Regenerative resistance connector (B+, B, BI)
 - Short-circuit B and BI terminals when using standard type
 - Use B+ and B terminals when using external resistor
- 7 Control power connector (C1, C2)
- 8 Servo motor connecting terminal (U,V,W)
- 9 Connector for analog monitor
- 10 Node address setting switch
- 11 USB connector (USB)
- 12 EtherCAT Communication port(IN)
- 13 EtherCAT Communication port(OUT)
- 14 Safety connector(STO)
- 15 Control signal connector (I/O)
- 16 Encoder connector(ENCODER)
- 17 Ground terminal

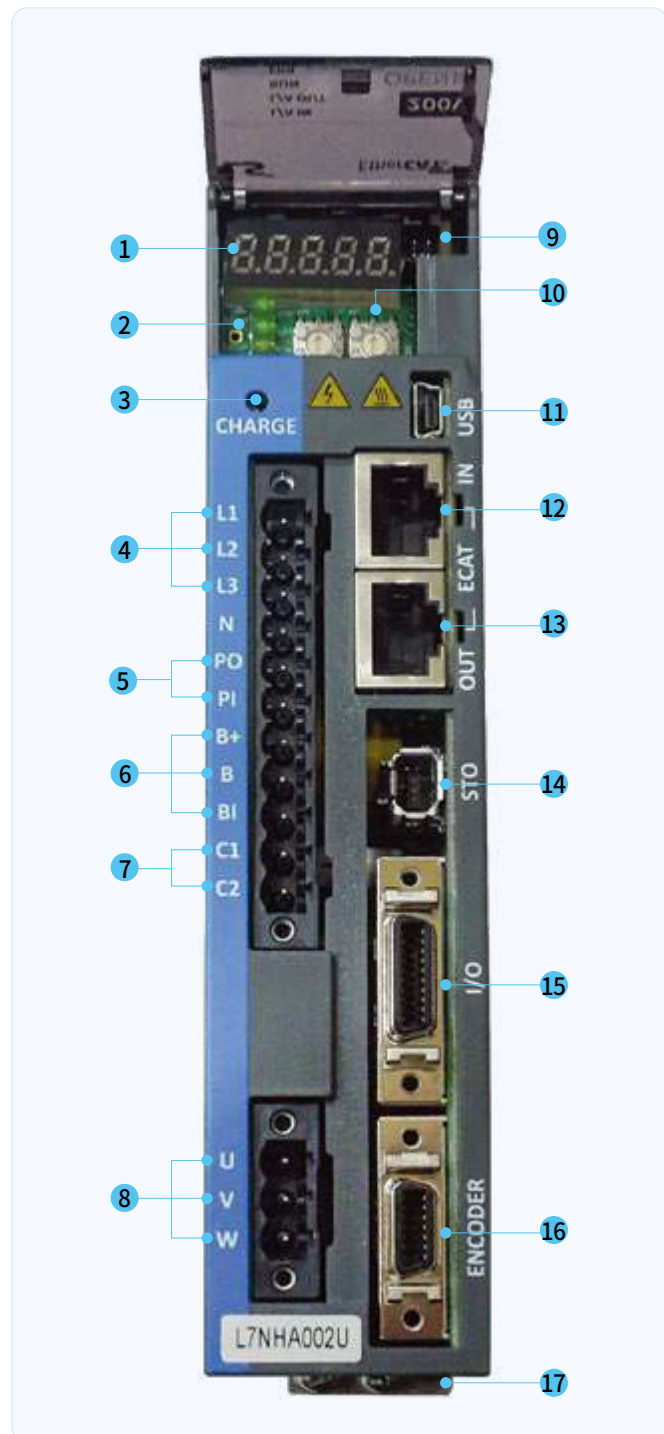

L7NHA Drive

Item	Type Name	L7NHA001U	L7NHA002U	L7NHA004U	L7NHA008U	L7NHA010U	L7NHA020U	L7NHA035U	L7NHA050U	L7NHA075U	L7NHA150U
Input Power	Main Power Supply	3 Phase AC200 ~ 230[V](-15 ~ +10[%]), 50 ~ 60[Hz]									
	Control Power Supply	Single Phase AC200 ~ 230[V](-15 ~ +10[%]), 50 ~ 60[Hz]									
Rated Current[A]		1.4	1.7	3.0	5.2	6.8	13.5	16.7	32.0	39.4	76.0
Peak Current[A]		4.2	5.1	9.0	15.6	20.3	40.5	50.1	90.9	98.5	190.0
Encoder Type		Quadrature(Incremental), BiSS-B, BiSS-C(Absolute, Incremental) Tamagawa Serial(Absolute, Incremental), EnDat 2.2 Sinusoidal, Analog Hall									
Control Performance	Speed Control Range	Maximum 1: 5000									
	Frequency Response	Maximum 1[kHz] or above(When the 19-bit Serial Encoder is applied)									
	Speed Variation Ratio	±0.01[%] or lower(When the load changes between 0 and 100%) ±0.1[%] or less(Temperature of 25°C[±10])									
	Torque Control Repetition Accuracy	Within ±1%									
EtherCAT Communication Specifications	Communication Standard	FoE (Firmware download) EoE (Parameter setting by UDP, Tuning, Secondary function, Parameter copy) CoE (IEC 61158 Type12, IEC 61800-7 CIA 402 Drive profile)									
	Physical Layer	100BASE-TX(IEEE802.3)									
	Connector	RJ45 x 2									
	Communication distance	Within connection between nodes 100[m]									
	DC(Distributed Clock)	Synchronization through DC mode, minimum DC cycle 250[μs]									
	LED Display	LinkAct IN, LinkAct OUT, RUN, ERR									
Cia402 Drive Profile		Profile Position Mode, Profile Velocity Mode, Profile Torque Mode Cyclic Synchronous Position Mode, Cyclic Synchronous Velocity Mode Cyclic Synchronous Torque Mode, Homing Mode									
Digital Input, Output	Digital Input	Input Voltage range : DC 12[V] ~ DC 24[V] Total 8 input channels (allocable) Total 12 functions (below) can be used selectively for assignment. (*POT, *NOT, *HOME, *STOP, *PCON, *GAIN2, *P_CL, *N_CL, PROBE1, PROBE2, EMG, A_RST)									
	Digital Output	Service rating: DC 24[V] ±10%, 120[mA] Total 4 input channels (allocable) Total 11 functions (below) can be used selectively for assignment. (*BRAKE±, *ALARM±, *READY±, *ZSPD±, INPOS±, TLMT±, VLMT±, INSPD±, WARN±, TGON±, INPOS±)									
Safety Function		2 Input Channels (STO1, STO2), 1 Output Channel (EDM±)									
USB Communication	Function	Firmware download, Parameter setting, Tuning, Secondary function, Parameter copy									
	Communication Standard	Complies with USB 2.0 Full Speed standard									
	Connect	PC or USB storing medium									
Internal Function	Dynamic Braking	Standard built-in brake (Activated when the servo alarm goes off or when the servo is off).									
	Regenerative Braking	Default built-in(excluding 15kW), external installation possible									
	Display Function	7-segment display (5 digits)									
	Self-setting Function	Drive node address customizable with rotary switch									
	Additional Function	Gain adjustment, alarm history, JOG operation, home search									
Protection Function		Overcurrent, overload, excessive current restriction, overheat, overvoltage, undervoltage, overspeed, encoder problem, location sensor problem, current sensor problem									
Operation Environment	Operating Temperature / Storage Temperature	0 ~ +50[°C] / -20 ~ +70[°C]									
	Operating Humidity / Storage Humidity	Below 80[%]RH / Below 90[%]RH(Noncondensing)									
	Environment	Keep indoors. Avoid corrosive / flammable gas or liquid, and electrically conductive dust.									

L7NHB Drive

Item	Type Name	L7NHB010U	L7NHB020U	L7NHB035U	L7NHB050U	L7NHB075U	L7NHB150U
Input Power	Main Power Supply	3 Phase AC 380 ~ 480[V](-15 ~ 10[%]), 50 ~ 60[Hz]					
	Control Power Supply	Single Phase AC 380 ~ 480[V](-15 ~ 10[%]), 50 ~ 60[Hz]					
Rated Current[A]		3.7	8.0	10.1	17.5	22.8	39.0
Peak Current[A]		11.1	24.0	30.3	47.3	57.0	97.5
Encoder Type		Quadrature(incremental), BiSS-B, BiSS-C(absolute, incremental), Tamagawa Serial(absolute, incremental), Panasonic Serial(absolute), EnDat 2.2, Sinusoidal, Analog Hall					
Control Performance	Speed Control Range	Maximum 1: 5000					
	Frequency Response	Maximum 1[kHz] or above(When the 19-bit Serial Encoder is applied)					
	Speed Variation Ratio	±0.01[%] or lower(When the load changes between 0 and 100%) ±0.1[%] or less(Temperature of 25°C±10)					
	Torque Control Repetition Accuracy	Within ±1%					
EtherCAT Communication Specifications	Communication Standard	FoE (Firmware download) EoE (parameter setting through UDP, tuning, auxiliary functions, parameter copy), Tuning, Secondary function, Parameter copy) CoE (IEC 61158 Type12, IEC 61800-7 CIA 402 Drive profile)					
	Physical Layer	100BASE-TX(IEEE802.3)					
	Connector	RJ45 x 2					
	Communication distance	Within connection between nodes 100[m]					
	DC(Distributed Clock)	Synchronization through DC mode, minimum DC cycle 250[μs]					
	LED Display	LinkAct IN, LinkAct OUT, RUN, ERR					
	Cia402 Drive Profile	Profile Position Mode, Profile Velocity Mode Profile Torque Mode, Cyclic Synchronous Position Mode Cyclic Synchronous Velocity Mode, Cyclic Synchronous Torque Mode, Homing Mode					
Digital Input, Output	Digital Input	Input Voltage range : DC 12[V] ~ DC 24[V] Total 8 input channels (allocable) Total 12 functions (below) can be used selectively for assignment. (*POT, *NOT, *HOME, *STOP, *PCON, *GAIN2, *P_CL, *N_CL, PROBE1, PROBE2, EMG, A_RST)					
	Digital Output	Service rating: DC 24[V] ±10%, 120[mA] Total 4 input channels (allocable) Total 11 functions (below) can be used selectively for assignment. (*BRAKE±, *ALARM±, *READY±, *ZSPD±, INPOS±, TLMT±, VLMT±, INSPD±, WARN±, TGON±, INPOS±)					
Safety Function		2 Input Channels (ST01, ST02), 1 Output Channel (EDM±)					
USB Communication	Function	Firmware download, Parameter setting, Tuning, Secondary function, Parameter copy					
	Communication Standard	Complies with USB 2.0 Full Speed standard					
	Connect	PC or USB storing medium					
Internal Function	Dynamic Braking	Standard built-in brake (activated when the servo alarm goes off or when the servo is off).					
	Regenerative Braking	Default built-in(excluding 15kW), external installation possible					
	Display Function	7-segment display (5 digits)					
	Self-setting Function	Drive node address customizable with rotary switch					
	Additional Function	Gain adjustment, alarm history, JOG operation, home search					
	Protection Function	Overcurrent, overload, excessive current restriction, overheat, overvoltage, undervoltage, overspeed, encoder problem, location sensor problem, current sensor problem					
Operation Environment	Operating Temperature / Storage Temperature	0 ~ +50[°C] / -20~ +70[°C]					
	Operating Humidity / Storage Humidity	Below 80[%]RH / Below 90[%]RH(Noncondensing)					
	Environment	Keep indoors. Avoid corrosive / flammable gas or liquid, and electrically conductive dust.					

*Unit [mm]

L7NHA001U ~ L7NHA004U
[Weight: 1.0kg]

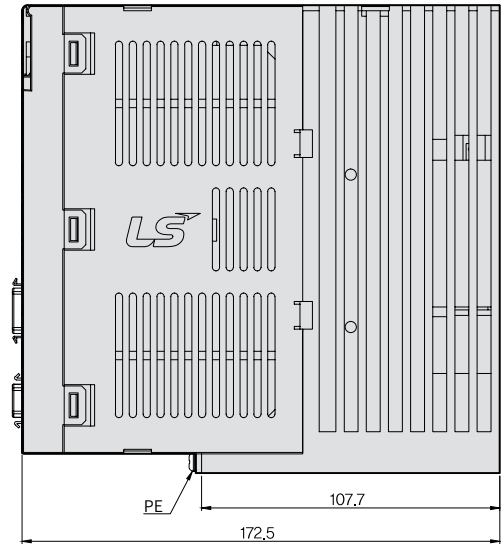
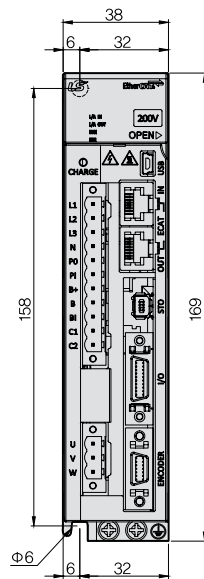

*Unit [mm]

L7NHA008U / L7NHA010U
[Weight: 1.5kg
(Fan-Cooling included)]

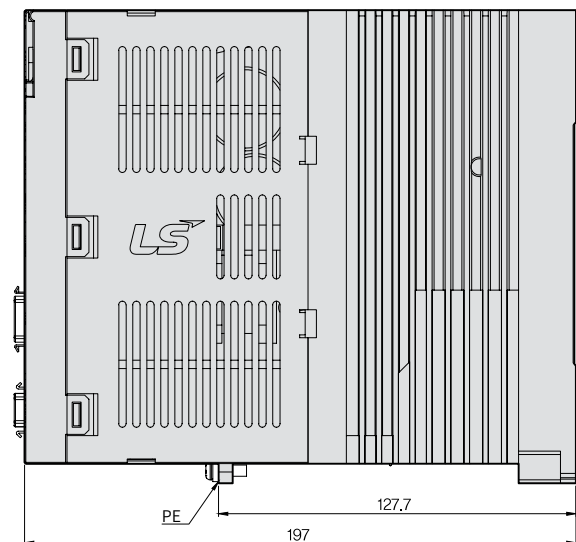
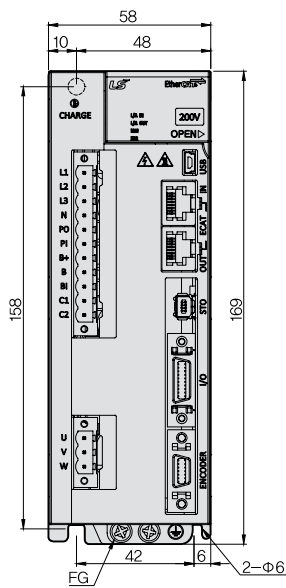

*Unit [mm]

L7NHA020U / L7NHA035U

[Weight: 2.5kg
[Fan-Cooling included]]

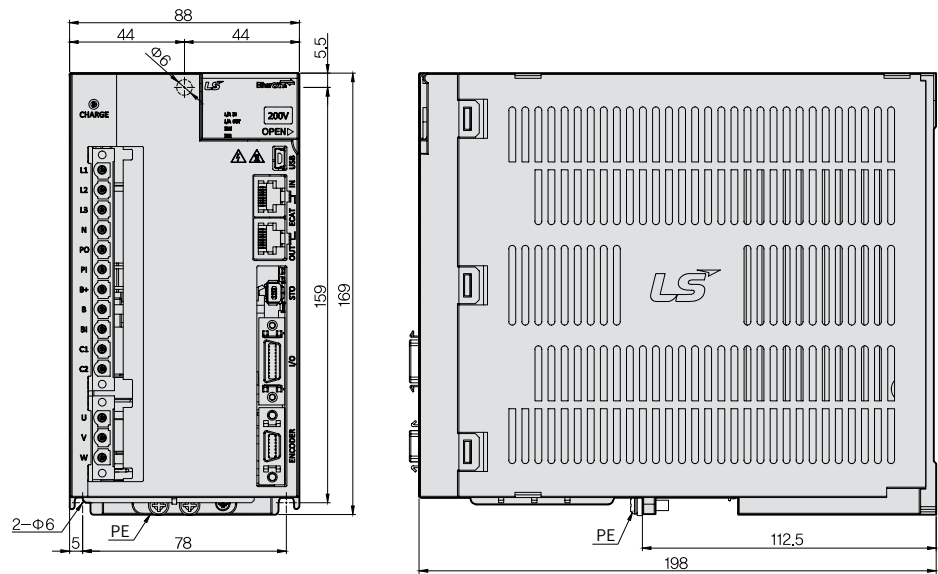

*Unit [mm]

L7NHA050U

[Weight: 5.5kg
[Fan-Cooling included]]

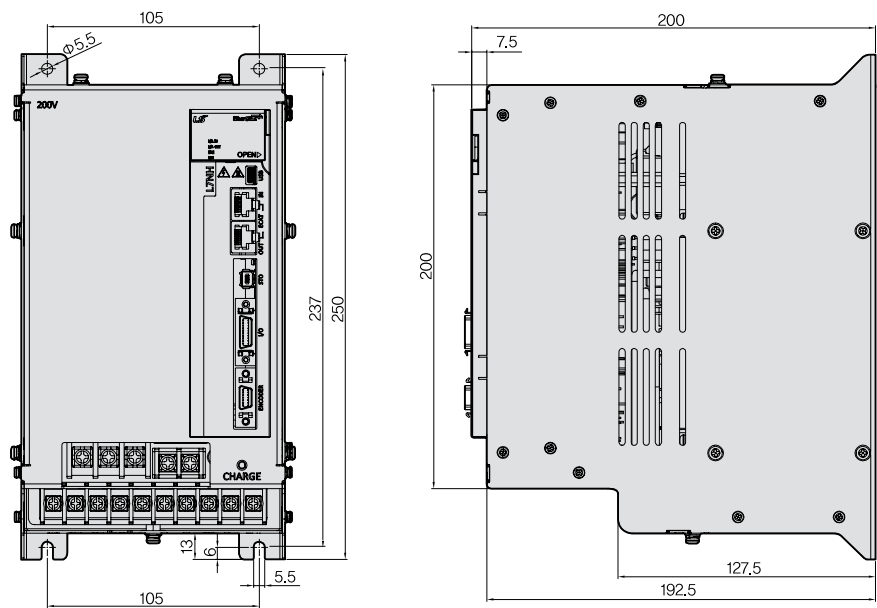

Servo Drive

*Unit [mm]

L7NHA075U

[Weight: 8.5kg
[Fan-Cooling included]]

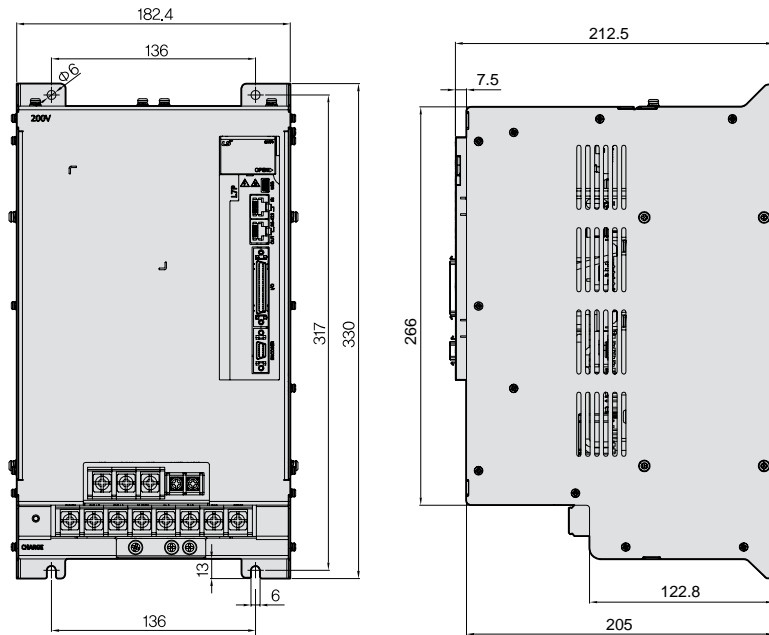

*Unit [mm]

L7NHA150U

[Weight: 16.2kg
[Fan-Cooling included]]

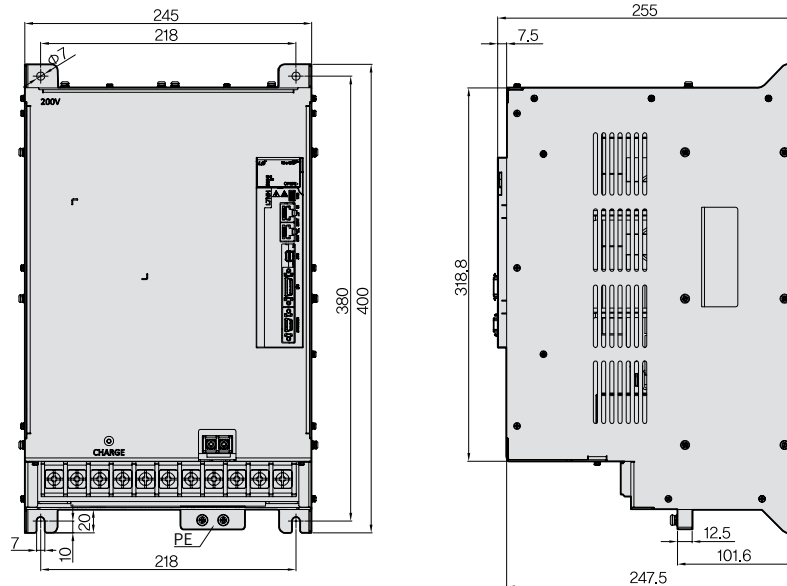

*Unit [mm]

L7NHB010U
 [Weight: 1.5kg
 (Fan-Cooling included)]

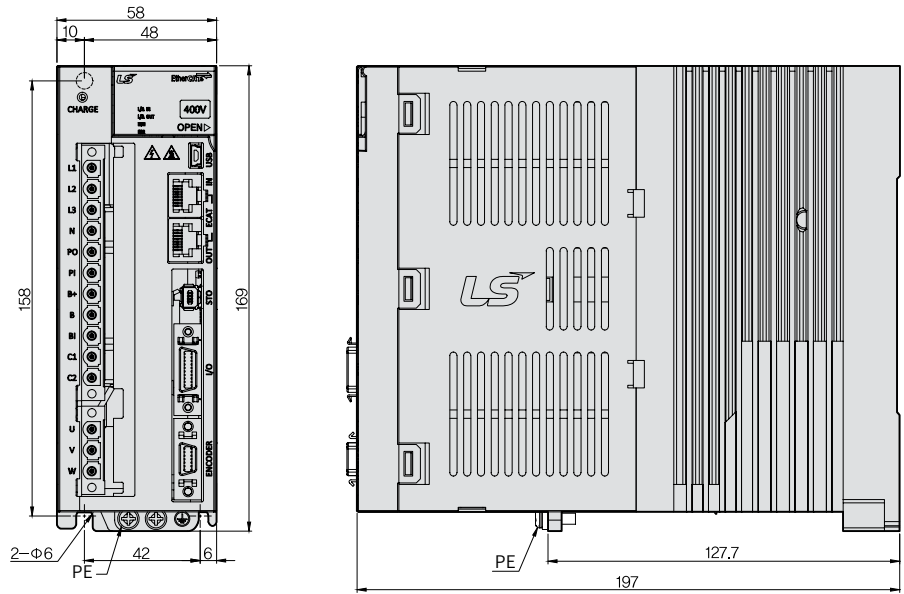

*Unit [mm]

L7NHB020U / L7NHB035U
 [Weight: 2.5kg
 (Fan-Cooling included)]

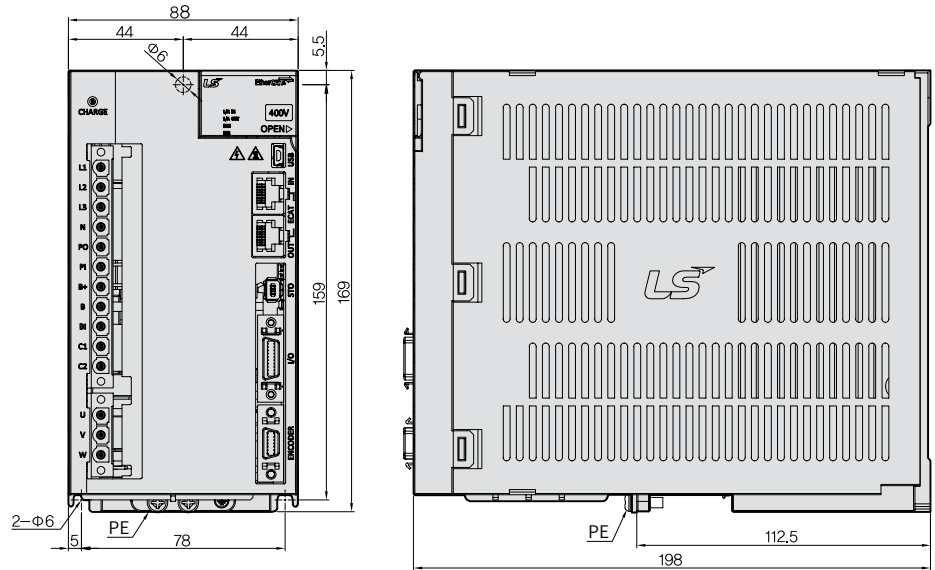

Servo Drive

*Unit [mm]

L7NHB050U

[Weight: 5.5kg
(Fan-Cooling included)]

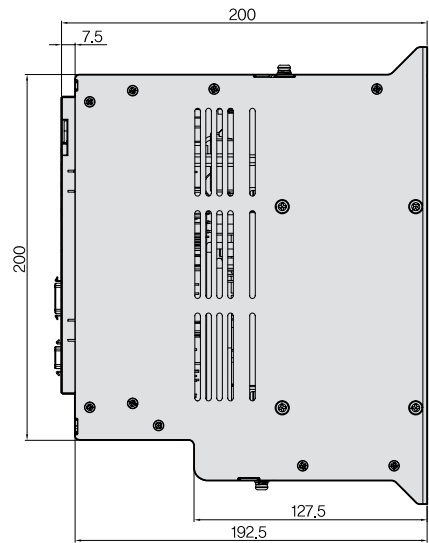
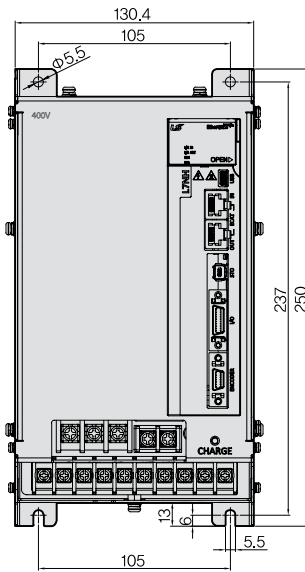

*Unit [mm]

L7NHB075U

[Weight: 8.5kg
(Fan-Cooling included)]

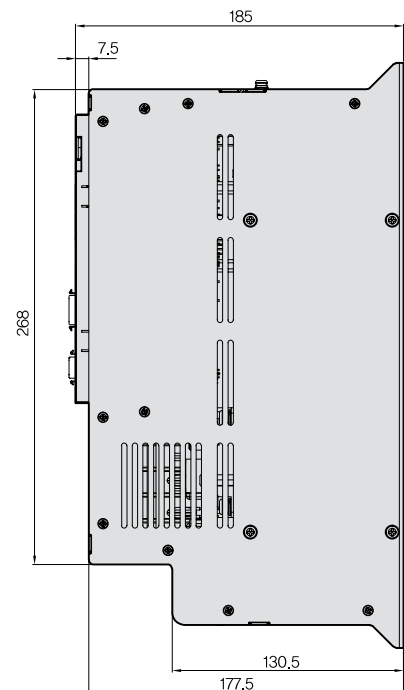
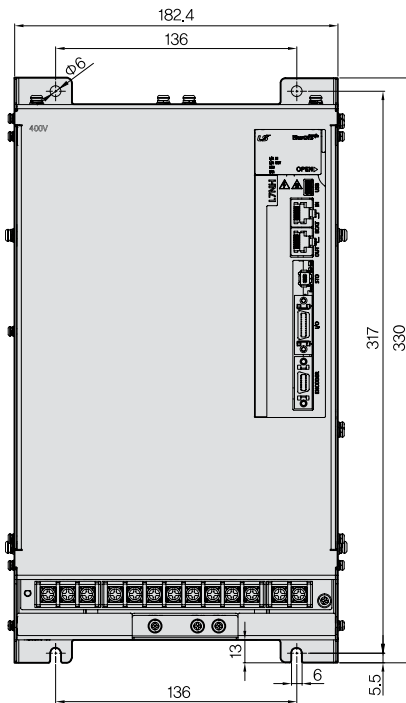

*Unit [mm]

L7NHB150U
 [Weight: 15.5kg
 (Fan-Cooling included)]

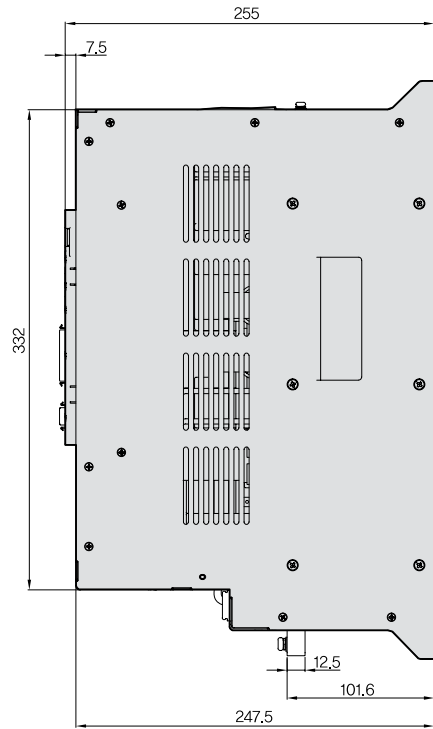
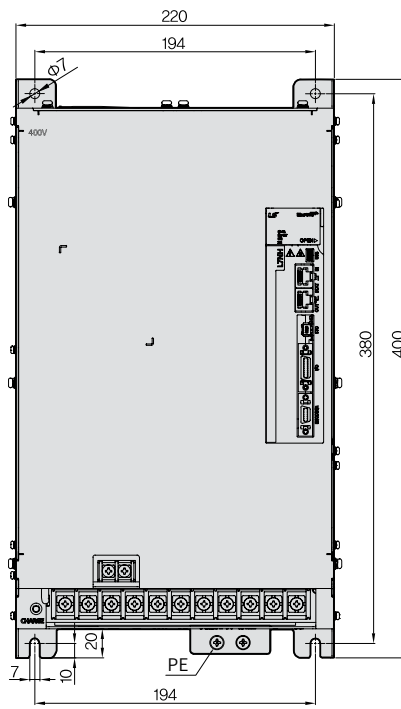

L7NHF Series



Servo Drive Designation

L7	NHF	A	010	U	AA
Communication	Input Power Supply	Capacity	Encoder Type	Option	
EtherCAT Type+ Full-Closed Type	A : 200VAC	004 : 400W 010 : 1.0kW 035 : 3.5kW 050 : 5.0kW 075 : 7.5kW	U : Universal	Exclusive Option Code	

All-in-One EtherCAT, Full-Closed System Control L7NHF

Real-time Control Through EtherCAT

- High speed, Real-time capability and synchronization mechanism
- Supports CoE, EoE and FoE
- Improved speed response($\approx 1\text{kHz}$) frequency
- Improved communication speed through 16-bit bus
 - Improved chip communication speed
 - Improved EtherCAT communication speed

Fully-closed Loop Control

- Switch among Semi-closed loop control, Fully-closed loop control and dual feedback control
- Fully-closed loop control provides quick response with internal and external encoder position values
- Fully-closed loop control ensures high-precision control during machine operation

- 1 Display
- 2 Charge Indicator
- 3 Status LED
- 4 Main power connector (L1, L2, L3)
- 5 DC Reactor connector (PO, PI)
- 6 Regenerative resistance connector (B+, B, BI)
- 7 Control power connector (C1, C2)
- 8 Servo motor connecting terminal (U,V,W)
- 9 Connector for analog monitor
- 10 Switch for node address setting
- 11 USB Connector
- 12 EtherCAT communication port (ECAT IN)
- 13 EtherCAT communication port (ECATOUT)
- 14 Safety connector(STO)
- 15 Input / output signal connector (I/O)
- 16 Encoder2 connector(ENCODER2)
- 17 Encoder connector(ENCODER)

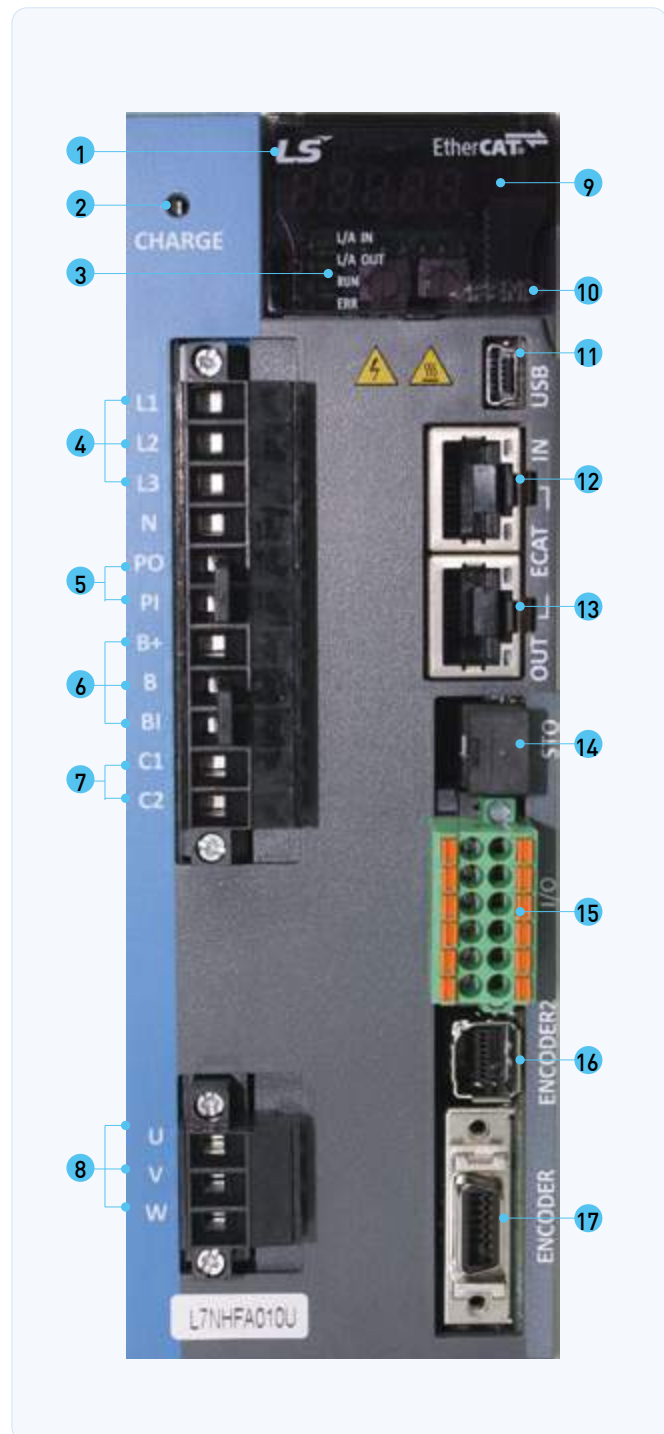

L7NHFA Drive

Item	Type Name	L7NHFA004U	L7NHFA010U	L7NHFA035U	L7NHFA050U	L7NHFA075U
Input Power	Main Power Supply	3 Phase AC200 ~ 230[V](-15 ~ +10[%]), 50 ~ 60[Hz]				
	Control Power Supply	Single Phase AC200 ~ 230[V](-15 ~ +10[%]), 50 ~ 60[Hz]				
Rated Current[A]		3.0	6.8	16.7	32	39.4
Peak Current[A]		9.0	20.3	50.1	90.9	98.5
1st Encoder Encoder A		Quadrature (Incremental), BiSS-B, BiSS-C (Absolute, Incremental) Tamagawa Serial (Absolute, Incremental), EnDat 2.2, Sinusoidal, Analog Hall				
2nd Encoder Encoder B		Quadrature (Incremental), SSI Sinusoidal, Analog Hall (Analog to BiSS converter)				
Control Performance	Speed Control Range	Maximum 1: 5000				
	Frequency Response	Maximum 1[kHz] or above(When the 19-bit Serial Encoder is applied)				
	Speed Variation Ratio	±0.01[%] or lower (When the load changes between 0 and 100%) ±0.1[%] or less(Temperature of 25°C[±10])				
	Torque Control Repetition Accuracy	Within ±1%				
	Input Frequency	4[Mpps], Lind Drive				
	Input Pulse Method	Symbol+Pulse series,CW+CCW,PhaseA/B				
Communication Specifications	Communication Standard	FoE (Firmware download) EoE (parameter setting through UDP, tuning, auxiliary functions, parameter copy) CoE (IEC 61158 Type12, IEC 61800-7 CIA 402 Drive profile)				
	Physical Layer	100BASE-TX (IEEE802.3)				
	Connector	RJ45 x 2				
	Communication distance	Within connection between nodes 100[m]				
	DC(Distributed Clock)	Synchronization through DC mode, minimum DC cycle 250[us]				
	LED Display	LinkAct IN, LinkAct OUT, RUN, ERR				
	Cia402 Drive Profile	Profile Position Mode, Profile Velocity Mode. Profile Torque Mode, Cyclic Synchronous Position Mode Cyclic Synchronous Velocity Mode, Cyclic Synchronous Torque Mode, Homing Mode				
Digital Input, Output	Digital Input	Input Voltage range : DC12[V] ~ DC 24[V] Total 6 input channels(allocable) Total 15 functions (below) can be used selectively for assignment. (*POT, *NOT, *HOME, *STOP, *PCON, *GAIN2, *P_CL, *N_CL, PROBE1, PROBE2, EMG, A_RST, SV_ON, LVSF, LVSF2) * Default signal				
	Digital Output	Total 3 input channels (Allocable) Total 11 functions (below) can be used selectively for assignment. (*BRAKE±, *ALARM±, *READY±, *ZSPD±, INPOS±, TLMT±, VLMT±, INSPD±, WARN±, TGON±, INPOS2±) * Default signal				
	Analog Output	Total 2 channels (Allocable) Total 25 output can be used selectively for assignment.				
Safety Function		2 Input Channels (STO1, STO2)				
USB Communication	Function	Firmware download, Parameter setting, Tuning, Secondary function, Parameter copy				
	Communication Standard	Complies with USB 2.0 Full Speed standard				
	Connect	PC or USB storing medium				
Internal Function	Dynamic Braking	Standard built-in brake (activated when the servo alarm goes off or when the servo is off).				
	Regenerative Braking	Default built-in(excluding 15kW), external installation possible				
	Display Function	7-segment display (5 digits)				
	Self-setting Function	Drive node address customizable with rotary switch				
	Additional Function	Gain adjustment, alarm history, JOG operation, home search				
	Protection Function	Overcurrent, overload, excessive current restriction, overheat, overvoltage, undervoltage, overspeed, encoder problem, location sensor problem, current sensor problem				
Operation Environment	Operating Temperature / Storage Temperature	0 ~ 50[°C] ~ -20 ~ 65[°C]				
	Operating Humidity / Storage Humidity	Below 80[%]RH / Below 90[%]RH(Noncondensing)				
	Environment	Keep indoors. Avoid corrosive / flammable gas or liquid, and electrically conductive dust.				

L7NHF Series I/O & Encoder2 PIN MAP

I/O Connector

PIN No.	Signal	PIN No.	Signal
1	DICOM	7	DI6
2	FG	8	DI5
3	D2	9	DO2
4	DI1	10	DO1
5	DI4	11	DOCOM
6	DI5	12	DO3

DFMC 1.5 / 6-STF-3.5 (PHOENIX)

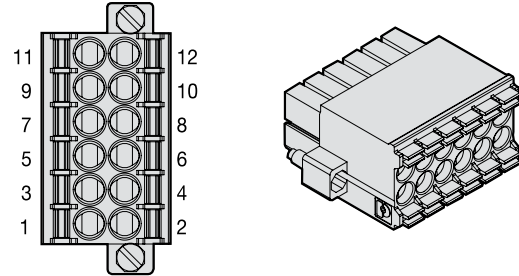

Encoder2 Connector

MUF-PK8K-X (JST)

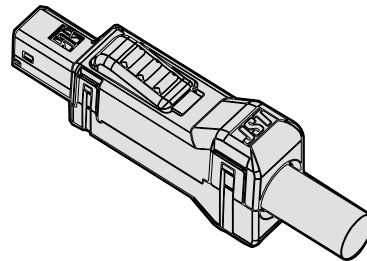
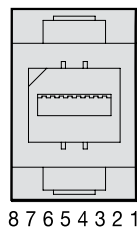

PIN No.	Signal(Quadrature)	Signal(SS1)	PIN No.	Signal(Quadrature)	Signal(SS1)
1	5V	5V	5	B	CLK
2	GND	GND	6	/B	/CLK
3	A	DATA	7	Z	Z
4	/A	/DATA	8	/Z	/Z

*Unit [mm]

L7NHFA004U

[Weight: 1.0kg]

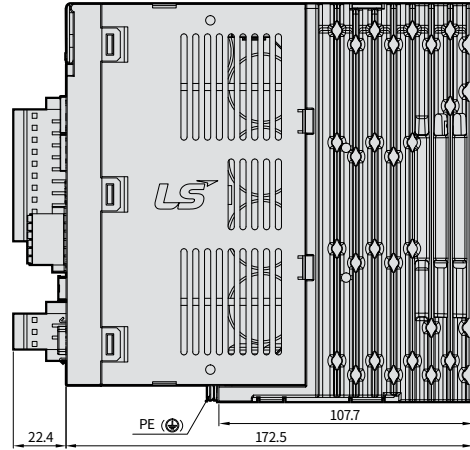
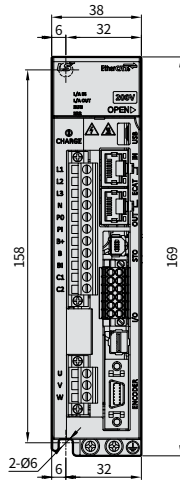

*Unit [mm]

L7NHFA010U

[Weight: 1.5kg]

[Fan-Cooling included]

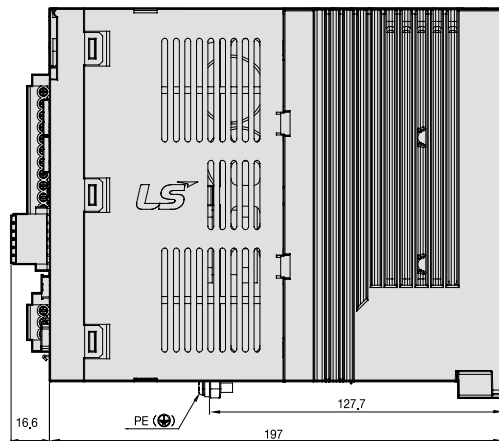
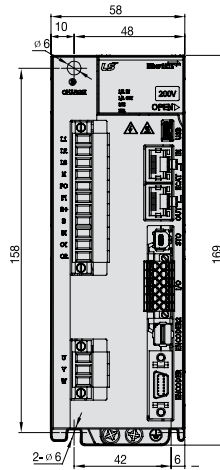

*Unit [mm]

L7NHFA035U

[Weight: 2.5kg]

[Fan-Cooling included]

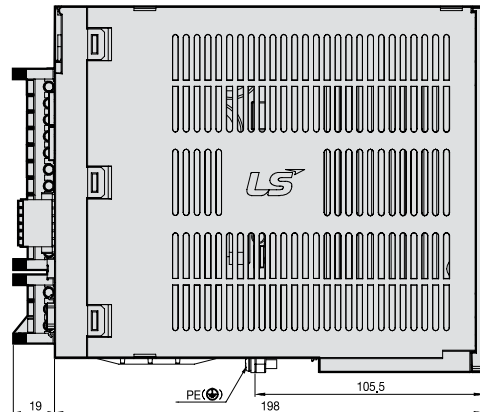
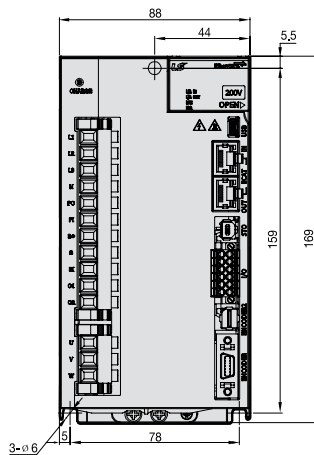

*Unit [mm]

L7NHFA050U

[Weight: 1.5kg
[Fan-Cooling included]]

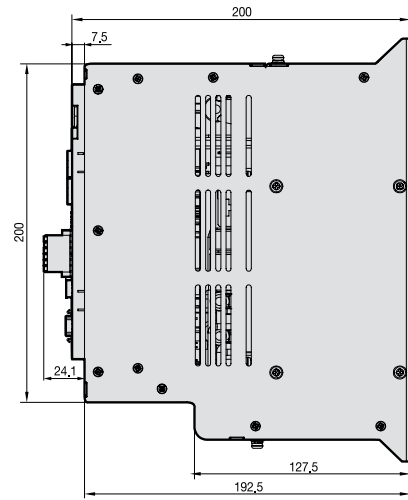
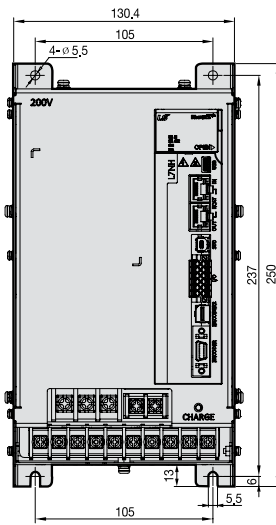

*Unit [mm]

L7NHFA075U

[Weight: 2.5kg
[Fan-Cooling included]]

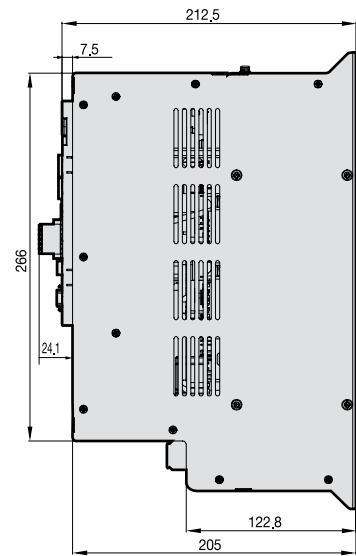
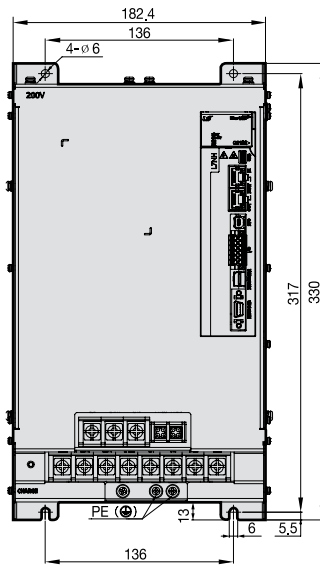

L7S Series



Servo Drive Designation

L7	S	A	004	B	AA
Communication	Input Power Supply	Capacity (A: 200VAC)	Capacity (B: 400VAC)	Encoder Type	Option
Standard I/O Type	A : 200VAC B : 400VAC	001 : 100W 002 : 200W 004 : 400W 008 : 750W 010 : 1.0kW 020 : 20kW 035 : 3.5kW 050 : 5.0kW 075 : 7.5kW 150 : 15kW	010 : 1.0kW 020 : 20kW 035 : 3.5kW 050 : 5.0kW 075 : 7.5kW 150 : 15kW	A : Incremental B : Serial	Exclusive Option Code

Standard Pulse and Analog Command Type **L7S**

Easy to USE

- Easy gain tuning with automatic inertia estimating function
- Easy setting Built-in panel operator
- Many I/O contacts and various functions (Digital input: 10 contacts, Digital output: 8 contacts / Analog input, output: 2 contacts)

Reliability for Protection Function

- CE, RoHS Certificated
- Drive Protection Function and Warn Function

High Response for Precise Control

- High-resolution serial type Serial type Encoder (19Bit, BiSS)
- Improved speed response frequency ($\approx 1\text{kHz}$)

- 1 Operation keys (Mode, Up, Down, Set)
- 2 Charge indicator
- 3 Main power connector (L1, L2, L3)
- 4 DC Reactor connector(PO, PI)
 - Short-circuit when not in use
- 5 Regenerative resistance connector (B+, B, BI)
 - Short-circuit B and BI terminals when using standard type
 - Use B+ and B terminals when using external resistor
- 6 Control power connector (C1, C2)
- 7 Front cover
- 8 Motor power cable connector (U, V, W)
- 9 Heat sink
- 10 Display
- 11 CN5: USB Connector
- 12 CN4: RS-422 communication connector
- 13 CN3: RS-422 communication connector
- 14 CN1: Control signal connector
- 15 CN2: Encoder signal connector
- 16 Ground

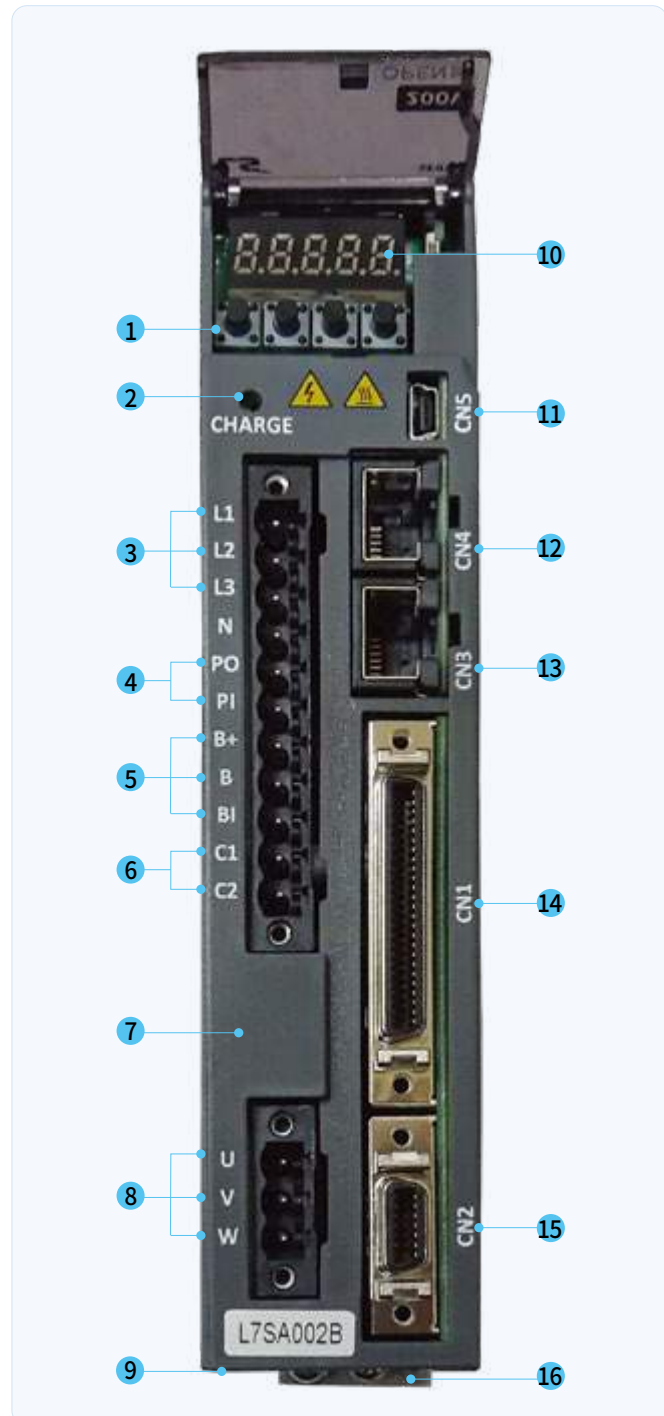

L7SA Drive

Item	Type Name	L7SA001□	L7SA002□	L7SA004□	L7SA008□	L7SA010□	L7SA020□	L7SA035□	L7SA050□	L7SA075B	L7SA150B	
Input Power	Main Power Supply	3 Phase AC200 ~ 230[V](-15 ~ +10[%]), 50 ~ 60[Hz]										
	Control Power Supply	Single Phase AC200 ~ 230[V](-15 ~ +10[%]), 50 ~ 60[Hz]										
Rated Current[A]		1.4	1.7	3.0	5.2	6.8	13.5	16.7	32.0	39.4	76.0	
Peak Current[A]		4.2	5.1	9.0	15.6	20.3	40.5	50.1	96.0	98.5	190.0	
Encoder Type		Quad. type incremental line drive 2,000~10,000[P/R], Serial 18bit 100W (for M8 only), 19Bit, 20Bit (for DD motor only)										
Control Performance	Speed Control	Speed Control Range	Maximum 1: 5000									
		Frequency Response	Maximum 1 [kHz] or above (when using 19bit serial encoder)									
		Speed Command	DC -10 [V]~+10 [V] (Reverse rotation in case of negative voltage)									
		Accel/Decel Time	Straight or S-curve acceleration/deceleration (0-10,000 [ms], possible to be set by one [ms] unit)									
		Speed Variation Ratio	±0.01[%] or lower (when load changes between 0 and 100%), ±0.1[%] or lower									
	Position Control	Input Frequency	1[Mpps], Line driver / 200[kpps], Open Collector									
		Input Pulse Type	Symbol + Pulse series, CW+CCW, A/B Phase									
		Electric Gear Ratio	Four digital gear ratios can be set, selected and tuned.									
	Torque Control	Torque Command	DC-10~+10 [V] (Reverse direction torque in case of negative voltage)									
		Speed Limit	DC 0~10 [V], internal speed command within ±1[%]									
Repetition accuracy		Within ±1[%]										
Input/Output Signal	Analog Input	Input Range	DC -10 ~ +10[V]									
		Resolution	12[bit]									
	Analog Output	Output Range	DC -10 ~ +10[V]									
		Resolution	12[bit]									
	Digital Input	Total 10 Input channels(Assignment available) SVON, SPD1, SPD2, SPD3, ALMRST, DIR, CCWLIM, CWLIM, EMG, STOP, EGEAR1, EGEAR2, PCON, GAIN2, P_CLR, T_LMT, MODE, ABS_RQ, ZCLAMP Above 19 functions can be used selectively for assignment. Signal can be set as positive logic or negative logic										
	Digital Output	Total 5 Channels(Assignment available), 3 Channels(Set as alarm code) ALARM, READY, ZSPD, BRAKE, INPOS, TLMT, VLMT, INSPD, WARN Above 9 outputs can be used selectively for assignment. Signal can be set as positive logic or negative logic										
Communication	RS-422	Accessible to PC software and the RS422 server										
	USB	Status monitoring, JOG operation, parameter upload/download are available with PC Software										
Encoder		Serial BiSS encoder and quadrature encoder supported										
Encoder Output Type		Random pre-scale output through FPGA (Maximum 6.4 Mpps)										
Built-in functions	Dynamic Braking	Standard built-in (Activated when the servo alarm goes off or when the servo is off)										
	Regenerative Braking	Default built-in(excluding 15kW), external installation possible										
	Display	7-segment display (5 digits)										
	Self-setting Function	Loader (SET, MODE, UP, and [DOWN] keys)										
	Additional Function	Auto gain tuning, phase Z detection, manual JOG operation, program JOG operation, automatic analog input calibration										
Protective Function	Overcurrent, overload, overvoltage, insufficient voltage, main power input problem, control power input problem, overspeed, motor cable, overheat(power module overheat, abnormal drive operation's temp), encoder problem, over-regenerative, sensor problem, communication problem											
Operation Environment	Operating Temperature / Storage Temperature	0 ~ +50[°C] / -20 ~ +70[°C]										
	Operating Humidity / Storage Humidity	Below 80[%]RH / Below 90[%]RH(Noncondensing)										
	Environment	Keep indoors. Avoid corrosive / flammable gas or liquid, and electrically conductive dust.										

* L7SA075 and L7SA150 do not support Incremental type

L7SB Drive

Item	Type Name	L7SB010B	L7SB020B	L7SB035B	L7SB050B	L7SB075B	L7SB150B	
Input Power	Main Power Supply	3 Phase AC380 ~ 480[V](-15 ~ +10[%]), 50 ~ 60[Hz]						
	Control Power Supply	Single Phase AC380 ~ 480[V](-15 ~ +10[%]), 50 ~ 60[Hz]						
Rated Current[A]		3.7	8.0	10.1	17.5	22.8	39.0	
Peak Current[A]		11.1	24.0	30.3	52.5	57.0	97.5	
Encoder Type		19Bit						
Control Performance	Speed Control	Speed Control Range	Maximum 1: 5000					
		Frequency Response	Maximum 1 [kHz] or above (when using 19bit serial encoder)					
		Speed Command	DC -10 [V]~+10 [V] (Reverse rotation in case of negative voltage)					
		Accel/Decel Time	Straight or S-curve acceleration/deceleration (0-10,000 [ms], possible to be set by one [ms] unit)					
		Speed Variation Ratio	±0.01 [%] or lower [When load changes between 0 and 100%], ±0.1[%] or lower [Temperature 25 ±10°C]					
	Position Control	Input Frequency	1[Mpps], Line driver / 200[kpps], Open collector					
		Input Pulse Type	Symbol + pulse series, CW+CCW, A/B phase					
		Electric Gear Ratio	Four digital gear ratios can be set, selected and tuned.					
	Torque Control	Torque Command	DC -10~+10 [V] (Reverse direction torque in case of negative voltage)					
		Speed Limit	DC 0~10 [V], internal speed command within ±1[%]					
Repetition accuracy		Within ±1[%]						
Input/Output Signal	Analog Input	Input Range	DC -10 ~ +10[V]					
		Resolution	12[bit]					
	Analog Output	Output Range	DC -10 ~ +10[V]					
		Resolution	12[bit]					
	Digital Input	A total of 10 input channels (Allocable) SVON, SPD1, SPD2, SPD3, ALMRST, DIR, CCWLIM, CWLIM, EMG, STOP, EGEAR1, EGEAR2, PCON, GAIN2, P_CLR, T_LMT, MODE, ABS_RQ, ZCLAMP You can selectively allocate a total of 19 functions. You can set the positive/negative logic of the selected signal.						
	Digital Output	A total of 5 channels (Allocable), 3 channels (Fixed with alarm codes) ALARM, READY, ZSPD, BRAKE, INPOS, TLMT, VLMT, INSPD, WARN You can selectively allocate a total of nine kinds of output. You can set the positive/negative logic of the selected signal.						
Communication	RS-422	Accessible to PC software and the RS422 server						
	USB	Status monitoring through PC software, JOG operation, and parameter uploading/downloading are possible.						
Encoder		Serial BiSS encoder and quadrature encoder supported						
Encoder Output Type		Random pre-scale output through FPGA (Maximum 6.4 Mpps)						
Built-in functions	Dynamic Braking	Standard built-in (Activated when the servo alarm goes off or when the servo is off)						
	Regenerative Braking	Default built-in (excluding 15kW), external installation possible						
	Display	7-segment display (5 digits)						
	Self-setting Function	Loader (SET, MODE, UP, and [DOWN] keys)						
	Additional Function	Auto gain tuning, phase Z detection, manual JOG operation, program JOG operation, automatic analog input calibration						
Protective Function	Overcurrent, overload, overvoltage, voltage lack, main power input error, control power input error, overspeed, motor cable, heating error (power module overheat, drive temperature error), encoder error, excessive regeneration, sensor error, communication error							
Operation Environment	Operating Temperature / Storage Temperature	0 ~ +50[°C] / -20 ~ +70[°C]						
	Operating Humidity / Storage Humidity	Below 80[%]RH / Below 90[%]RH(Noncondensing)						
	Environment	Keep indoors. Avoid corrosive / flammable gas or liquid, and electrically conductive dust.						

*Unit [mm]

L7SA001□~L7SA004□

[Weight: 1.0kg]

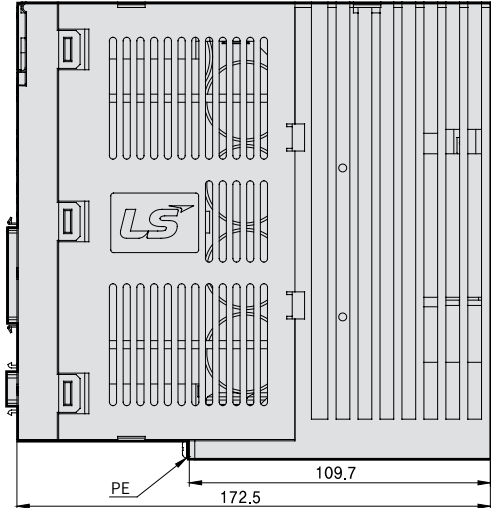
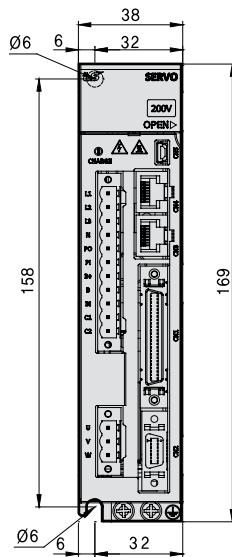

*Unit [mm]

L7SA008□~L7SA010□

[Weight: 1.5kg
[Fan-Cooling included]]

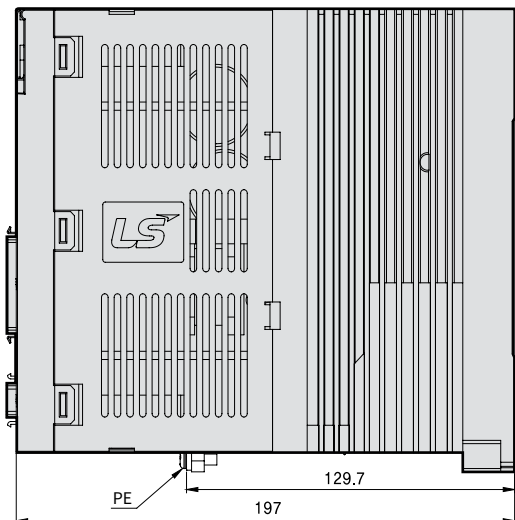
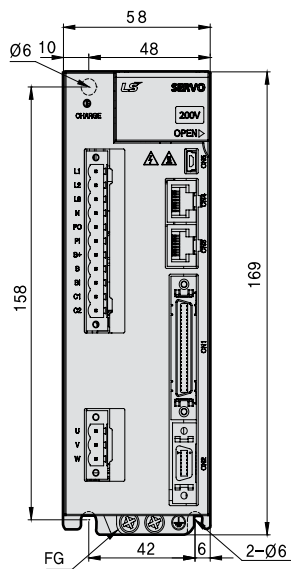

*Unit [mm]

L7SA020□~L7SA035□

[Weight: 2.5kg
[Fan-Cooling included]]

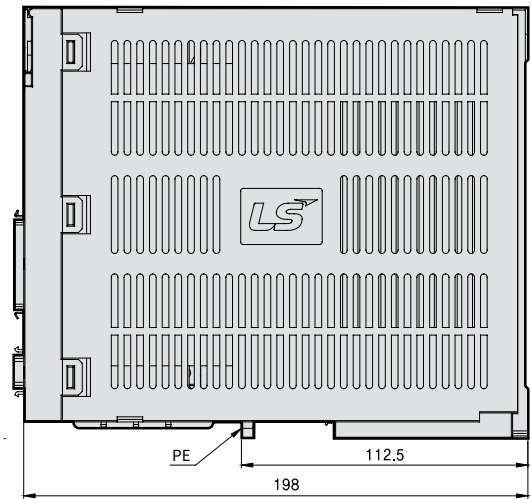
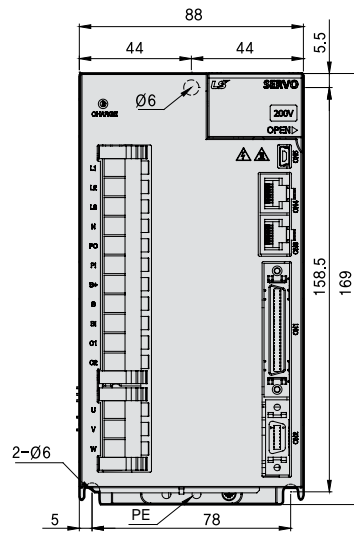

*Unit [mm]

L7SA050□

[Weight: 5.5kg
[Fan-Cooling included]]

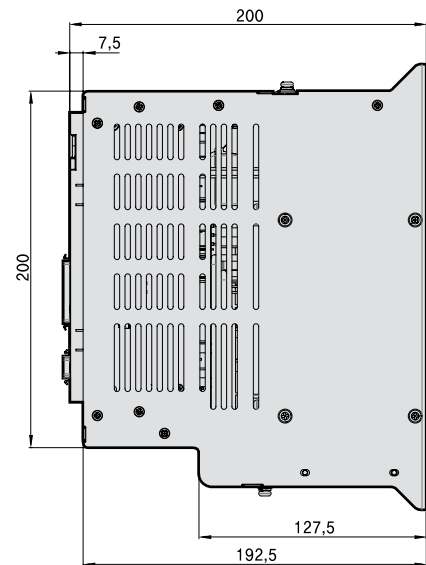
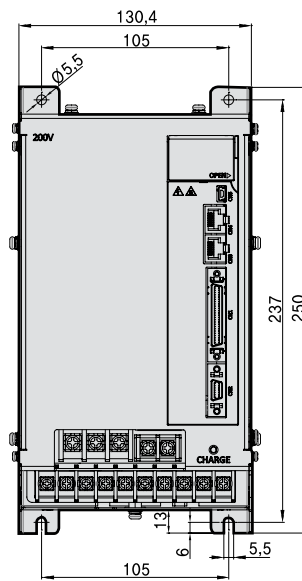

*Unit [mm]

L7SA075B

[Weight: 8.5kg
[Fan-Cooling included]]

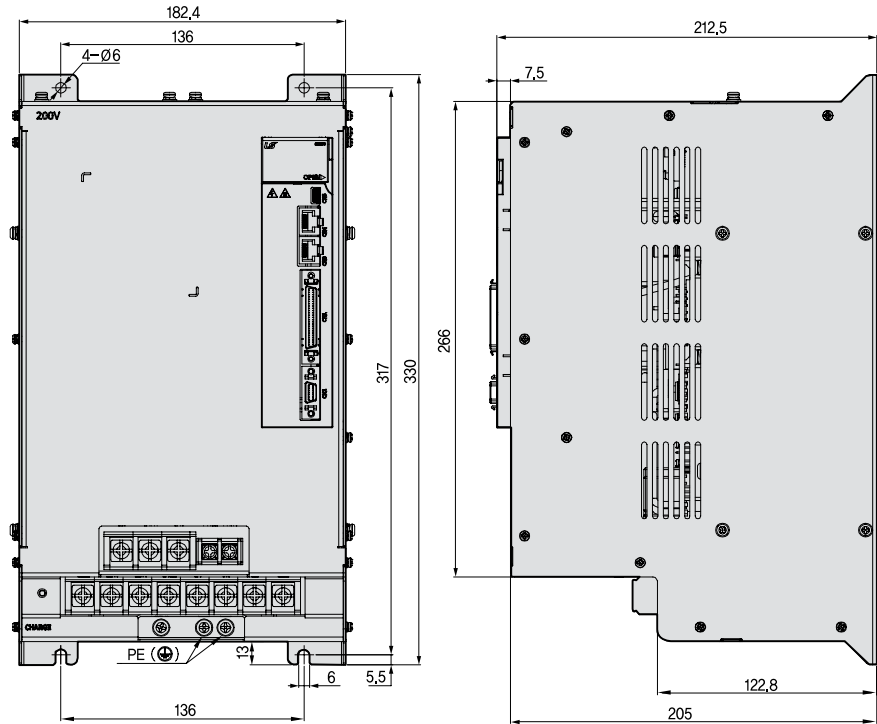

*Unit [mm]

L7SA150B

[Weight: 16.2kg
[Fan-Cooling included]]

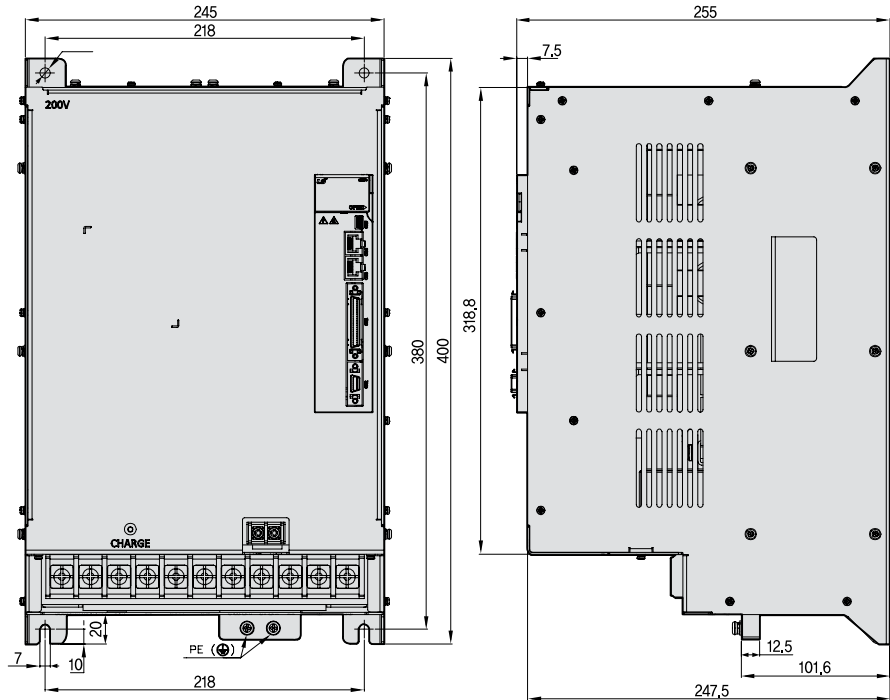

*Unit [mm]

L7SB010B

[Weight: 1.5kg
[Fan-Cooling included]]

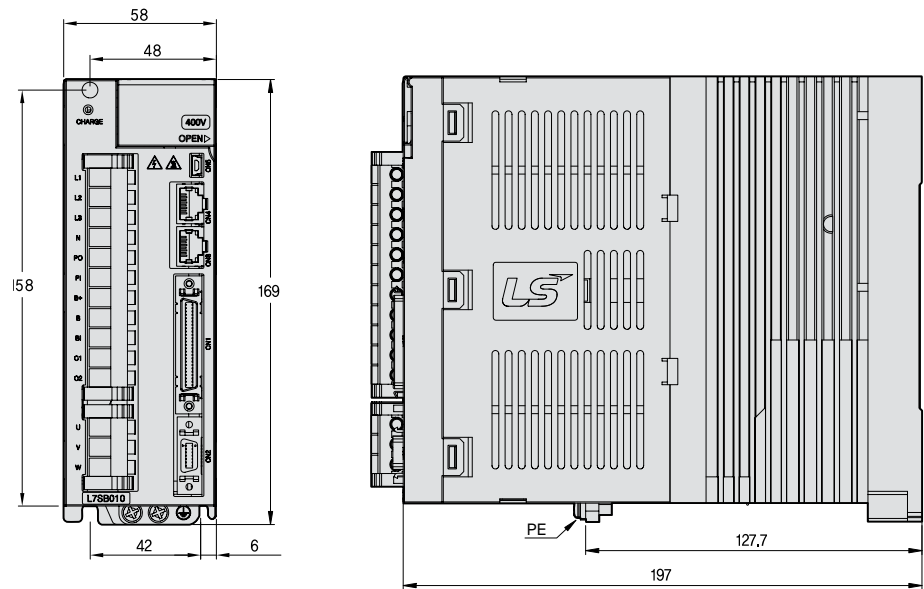

Servo Drive

*Unit [mm]

L7SB020B / L7SB035B

[Weight: 2.5kg
[Fan-Cooling included]]

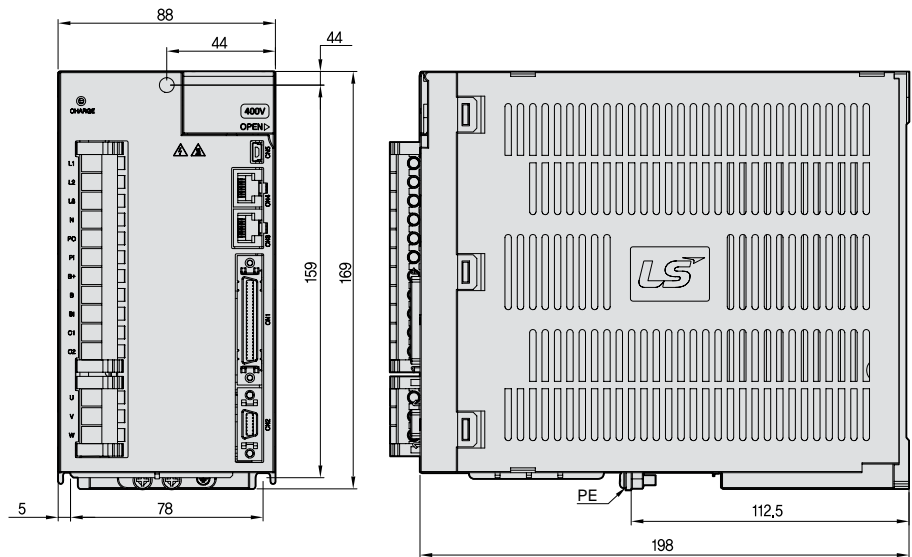

*Unit [mm]

L7SB050B

[Weight: 5.5kg
[Fan-Cooling included]]

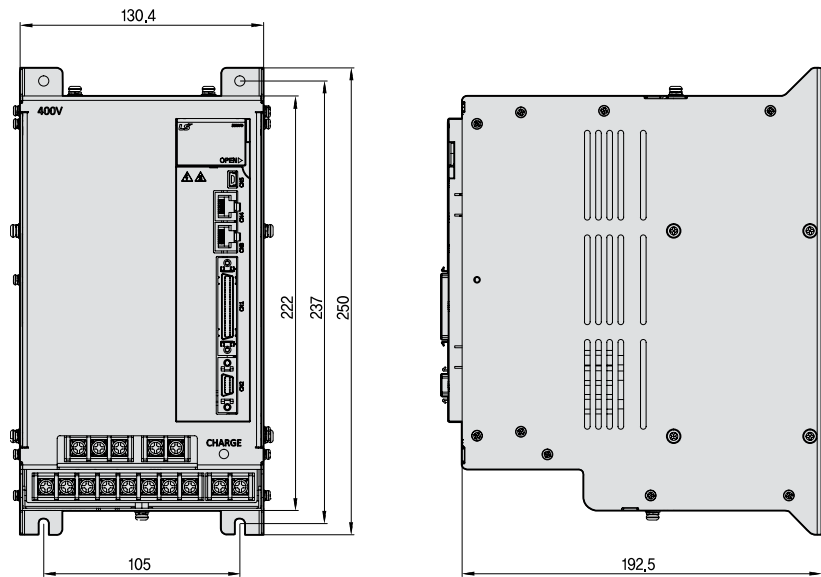

*Unit [mm]

L7SB075B

[Weight: 8.5kg
[Fan-Cooling included]]

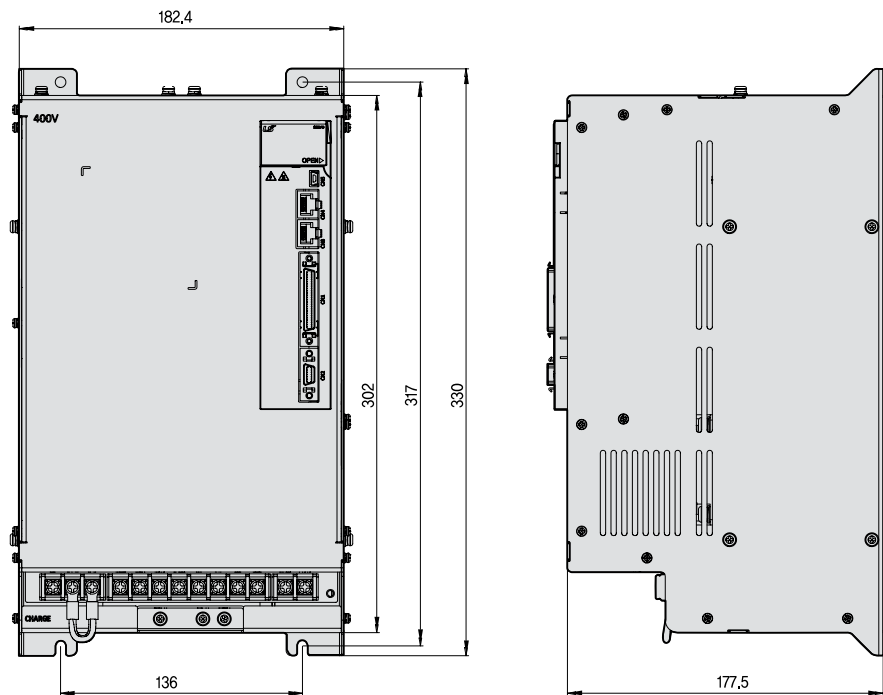

*Unit [mm]

L7SB150B

[Weight: 15.5kg
[Fan-Cooling included]]

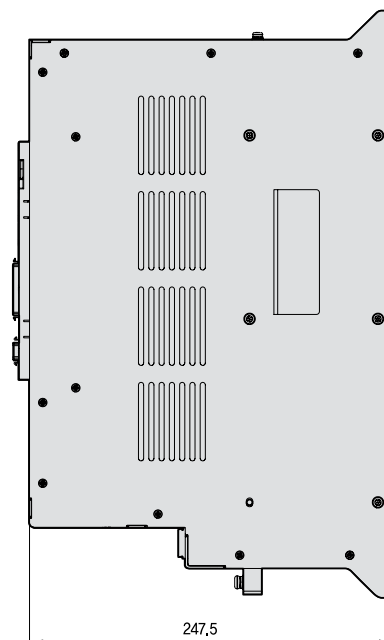
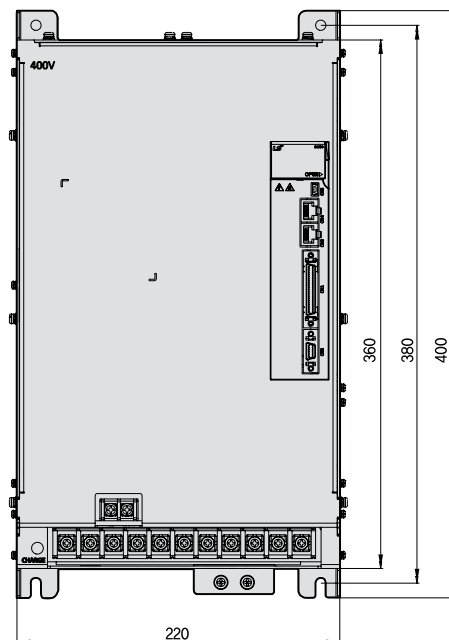

L7C Series



Servo Drive Designation

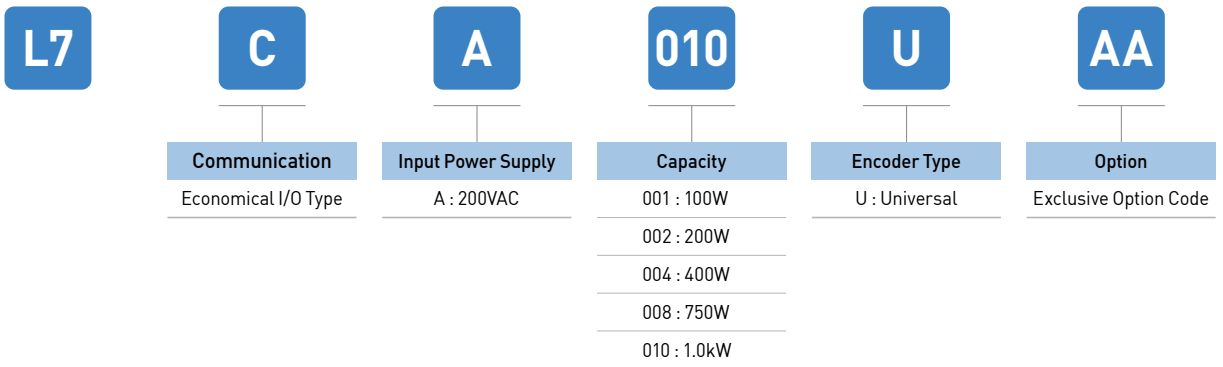

Economical Pulse and Analog Command Type **L7C**

Control Power/Main Power Unification

- Unified power supply with integrated control and power board
- Diverse product line supporting single-phase AC220, with capacities ranging from 0.1 to 1kW

Optimal Systems with Affordable Cost

- No FPGA used by the optimized MCU operation

Maintains L7S compatibility and specifications

- Compatibility with existing L7S I/O pin map
- Maintain current control cycle (10kHz), speed/position control cycle (5kHz)
- Added operation mode (indexing mode) and improved memory (1MB)

- 1 Display
- 2 Mode switch
- 3 Operation switch(Up/down)
- 4 Main power terminal (L1, L2)
- 5 Regenerative resistance terminal (B+, B)
- Mount external resistors to ports B+ and B
- 6 Servo motor power connectors (U, V, W)
- 7 Ground
- 8 Set-up switch
- 9 USB connector
- 10 Control signal connector(I/O)
- 11 Encoder connector(ENCODER)
- 12 Charge indicator

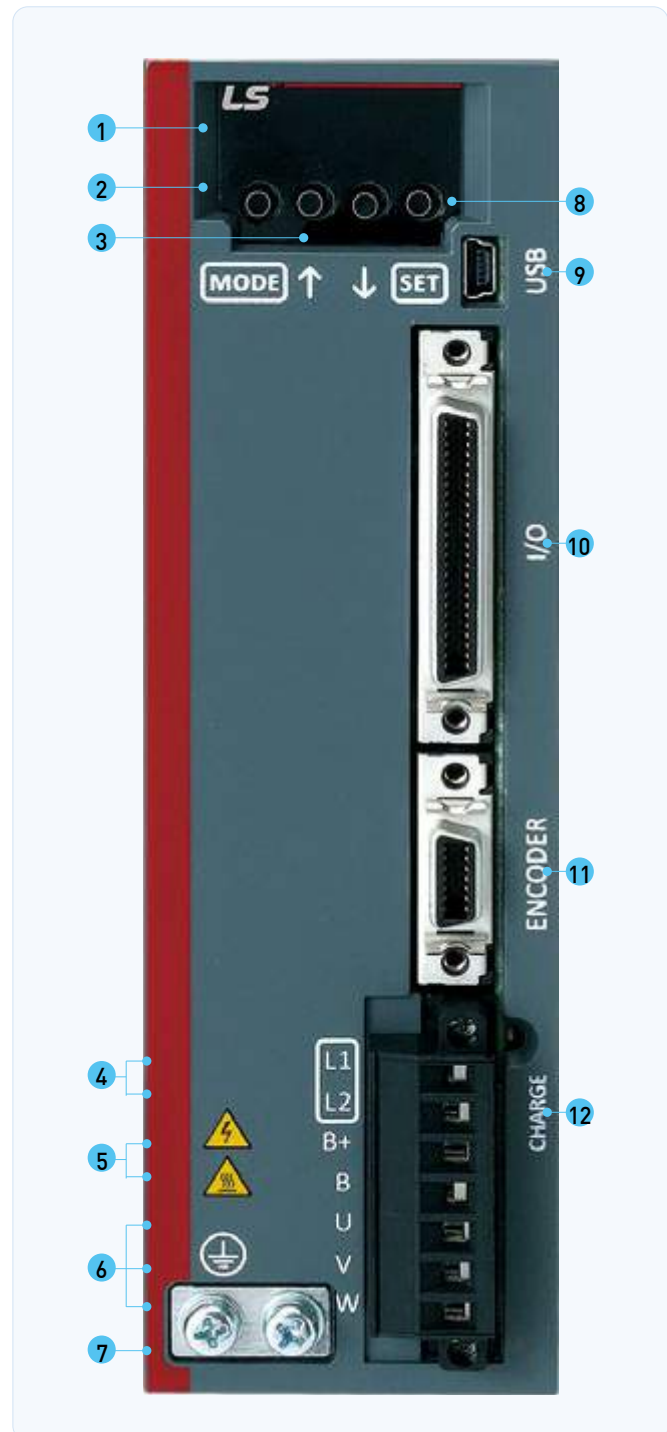

L7C Drive

Item	Type Name	L7CA001U	L7CA002U	L7CA004U	L7CA008U	L7CA010U
Input Power		Single phase AC200 ~ 230[V] (-15~+10%), 50~60[Hz]				
Rated Current[A]		1.4	1.7	3.0	5.2	6.75
Peak Current[A]		4.2	5.1	9.0	15.6	20.25
Encoder Type		Quadrature (Incremental), Biss-B, Biss-C (Absolute, Incremental)				
Control Performance	Speed Control Range	Maximum 1:5000				
	Frequency Response	Maximum 1[KHz] or above (When using 19Bit Serial Encoder)				
	Speed Variation Ratio	±0.01 [%] or lower [when load changes between 0 and 100%] ±0.1[%] or lower [Temperature 25 ±10°C]				
	Accel/Decel Time	Straight or S-curve acceleration/deceleration (0-10,000[ms], possible to be set by 0-1,000[ms] unit)				
	Input frequency	1[Mpps], line driver / 200[kpps], open collector				
	Input Pulse Type	Symbol + Pulse series, CW+CCW, A/B Phase				
Communication Specifications	Standards	ANSI/TIA/EIA-422 standard specifications				
	Protocol	MODBUS-RTU				
	Synchro Method	Asynchronous				
	Power Consumption	100mA or less				
	Transmission Speed	9,600 / 19,200 / 38,400 / 57,600bps				
	Distance	Maximum 200[m]				
	Terminating Resistance	External connection (CN1 7Pin, 28Pin connection), Built-in 120Ω				
Digital Input, Output	Digital Input	Input voltage range : DC12V ~ DC24V Total 10 input channels (allocable) Total 34 input functions allocable (*SV_ON, *SPD/LVSF1, *SPD2/LVSF2, *SPD3, *A-RST, *JDIR, *POT, *NOT, *EMG, *STOP, START, REGT, HOME, HSTART, ISEL0, ISEL1, ISEL2, ISEL3, ISEL4, ISEL5, PCON, GAIN2, P_CL, N_CL, MODE, PAUSE, ABSRQ, JSTART, PCLR, AOVR, INHIBIT, EGEAR1, EGEAR2, ABS_RESET) * Basic allocation signal				
	Digital Output	Service rating : DC24V ±10%, 120mA 5 of 8 input channels are allocable, 3 channels are fixed with AL00, AL01, AL02 Total 19 output functions allocable (*ALARM, *READY, *ZSPD, *BRAKE, *INPOS1, ORG, EOS, TGON, TLMT, VLMT, INSPD, WARN, INPOS2, IOUT0, IOUT1, IOUT2, IOUT3, IOUT4, IOUT5) * Basic allocation signal				
Analog Output		2 Channels Analog speed input (Command/Override) ±10V Analog torque input (Command/Limit) ±10V				
USB Communication	Connect	PC				
	Communication Standard	Complies with USB 2.0 Full Speed standard				
	Specification	PC, complies with USB 2.0 Full Speed standard				
Internal Function	Dynamic Braking	Standard built-in brake (Activated when the servo alarm goes off or when the servo is off),				
	Regenerative Braking	External installation possible (optional)				
	Display Function	7-segment display (5 digits)				
	Additional Function	Gain tuning, alarm history, JOG operation, origin search				
	Protection Function	Excessive current/voltage/overload/overheating/speed, excessive current limit, low voltage, encoder/position following/current sensing failure				
Operation Environment	Operating Temperature / Storage Temperature	0~50°C / -20 ~ 65°C				
	Operating Humidity / Storage Humidity	Below80[%]RH / Below 90[%]RH(Noncondensing)				
	Environment	Keep indoors. Avoid corrosive / flammable gas or liquid, and electrically conductive dust.				

External Dimensions

*Unit [mm]

**L7CA001U / L7CA002U /
L7CA004U**
[Weight: 1.0kg]

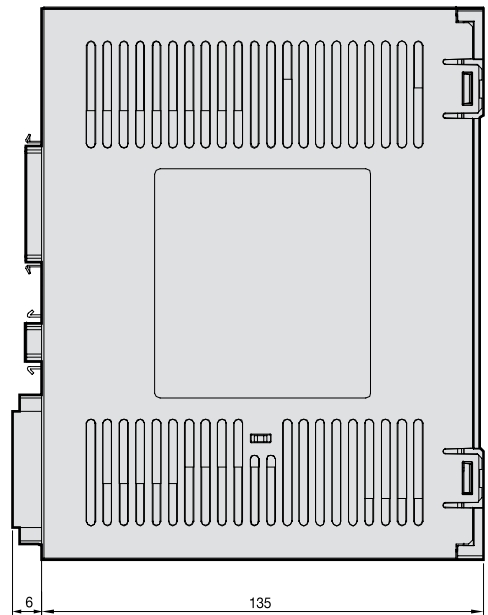
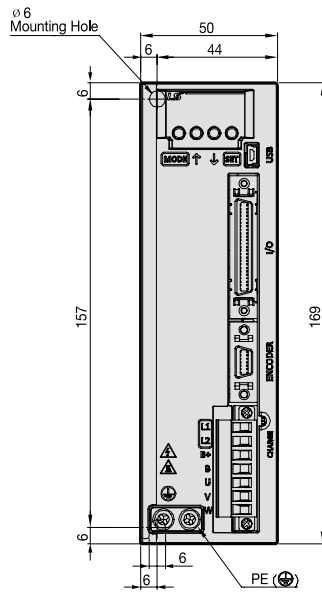

Servo Drive

*Unit [mm]

L7CA008U / L7CA010U
[Weight: 1.5kg]

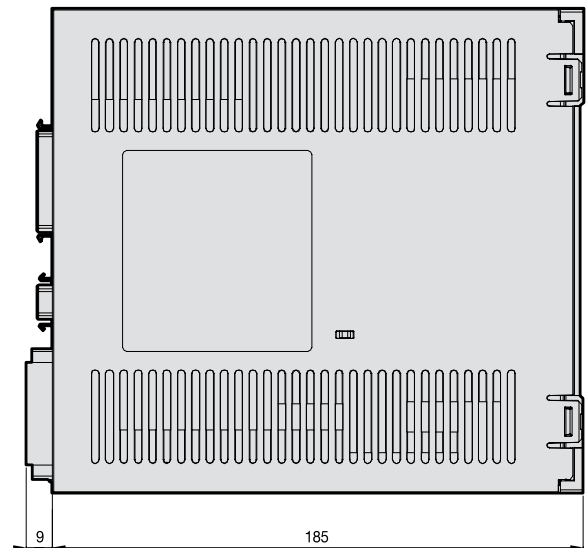
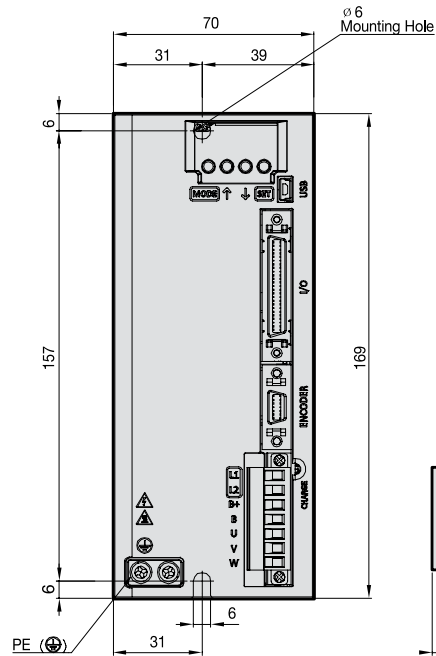

L7P Series



Servo Drive Designation

L7	P	A	004	U	AA
Communication	Input Power Supply	Capacity (A: 200VAC)	Capacity (B: 400VAC)	Encoder Type	Option
Standard I/O & Index Type	A : 200VAC B : 400VAC	001 : 100W 002 : 200W 004 : 400W 008 : 750W 010 : 1.0kW 020: 20kW 035 : 3.5kW 050 : 5.0kW 075 : 7.5kW 150 : 15kW	010 : 1.0kW 020: 20kW 035 : 3.5kW 050 : 5.0kW 075 : 7.5kW 150 : 15kW	U : Universal	Exclusive Option Code

Standard Pulse and Indexer Type **L7P**

Provides Program Function with Built-in Single Axis Position Determination Module

- Supports position control mode through pulse input
- Provides position control through I/O or HMI without position control module
- Drive operable by itself
- Modbus RTU protocol (RS-422)

Compatible with Various Motors and Encoders

- Operates with rotary, DD and linear motors (Supporting 3rd party motor)
- Quadrature, BiSS-C, Tamagawa serial abs, Endat 2.2, Panasonic serial abs, Sinusoidal

Improved Control Performance

- Improved control bandwidth
- 4-step notch filter provided
- Vibration control by Real-time FET
- Real-time gain tuning function

- 1 Display
- 2 Terminating resistance switch
- 3 Charge indicator
- 4 Main power connector (L1, L2, L3)
- 5 DC reactor connector (PO, PO), short-circuit when not in use
- 6 Regenerative resistor connector (B+, B, BI)
 - Short-circuit B and BI terminals when using standard type
 - Use B+ and B terminals when using external resistor
- 7 Control power connector (C1, C2)
- 8 Servo motor power connector (U, V, W)
- 9 Connector for analogue monitor
- 10 Node address switch
- 11 USB connector (USB)
- 12 RS-422 communication connector (CN3, CN4)
- 13 Control signal connector (I/O)
- 14 Encoder connector (ENCODER)
- 15 Ground

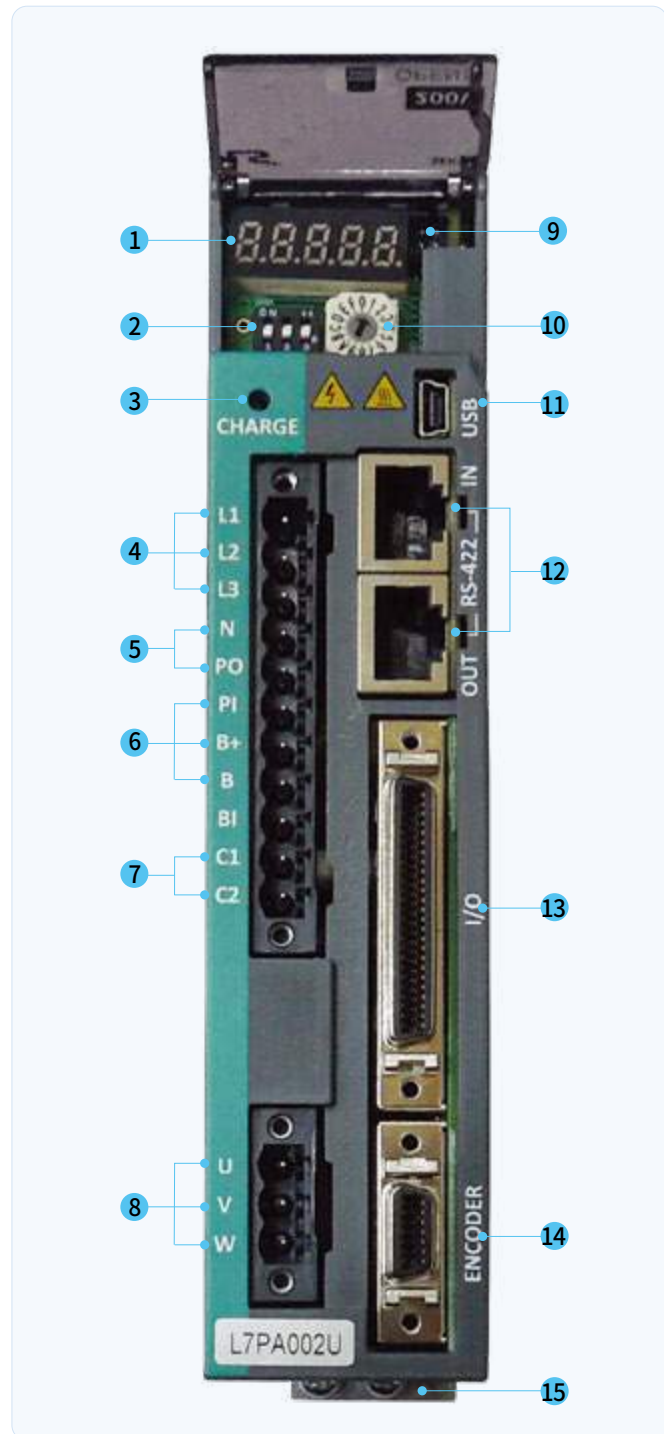

L7PA Drive

Item	Type Name	L7PA001U	L7PA002U	L7PA004U	L7PA008U	L7PA010U	L7PA020U	L7PA035U	L7PA050U	L7PA075U	L7PA150U
Input Power	Main Power Supply	3 Phase AC200 ~ 230[V](-15 ~ +10[%]), 50 ~ 60[Hz]									
	Control Power Supply	Single Phase AC200 ~ 230[V](-15 ~ +10[%]), 50 ~ 60[Hz]									
Rated Current[A]		1.4	1.7	3.0	5.2	6.8	13.5	16.7	32.0	39.4	76.0
Peak Current[A]		4.2	5.1	9.0	15.6	20.3	40.5	50.1	90.9	98.5	190.0
Encoder Type		Quadrature(Incremental), BiSS-B, BiSS-C(Absolute, Incremental), Tamagawa Serial(Absolute, Incremental), Panasonic Serial(Absolute), EnDat 2.2, Sinusoidal, Analog Hall									
Control Performance	Speed Control Range	Maximum 1: 5000									
	Frequency Response	Maximum 1 [kHz] or above (When using 19bit Serial Encoder)									
	Speed Variation Ratio	±0.01 [%] or lower [when load changes between 0 and 100%] ±0.1[%] or lower[Temperature25 ±10°C]									
	Accel/Decel Time	Straight or S-curve acceleration/deceleration (0~10,000[ms], 0~1,000[ms] Unit configurable)									
	Input Frequency	1[Mpps], line drive / 200[kpps], Open collector									
	Input Pulse Type	Symbol + Pulse series, CW+CCW, A/B Phase									
RS422 Communication Specifications	Communication Specifications	ANSI/TIA/EIA-422 Standard specifications									
	Communication Protocol	MODBUS-RTU									
	Connector	RJ45 x 2									
	Synchro Method	Asynchronous									
	Transmission Speed	9600/19200/38400/57600 [bps], Can be configured at [0x3002]									
	Transmission Distance	Maximum 200 [m]									
	Power Consumption	100[mA] or less									
	Terminating Resistance	Dip S/W(On/Off), Built-In 120Ω									
Digital Input, Output	Digital Input	Input voltage range: DC 12[V] ~ DC 24[V], total 16 input channel (allocable), 33 function inputs can be selectively allocated (*SV_ON, *POT, *NOT, *A-RST, *START, *STOP, *REGT, *EMG, *HOME, *HSTART, *ISEL0, *ISEL1, *ISEL2, *ISEL3, *ISEL4, *ISEL5, PCON, GAIN2, P_CL, N_CL, PROBE1, PROBE2, PAUSE, ABSRQ, JSTART, JDIR, PCLR, SPD1/LVSF1, SPD2/LVSF2, SPD3, AOV, INHIBIT, MODE)									
	Digital Output	Use rating: DC 24[V] ±10%, 120[mA], total 8 input channel (allocable) 19 function inputs can be selectively allocated (*ALARM±, *READY±, *BRAKE±, *INPOS1±, *ORG±, *EOS±, *TGON±, *TLMT±, VLMT±, INSPD±, ZSPD±, WARN±, INPOS2±, IOUT0±, IOUT1±, IOUT2±, IOUT3±, IOUT4±, IOUT5±)									
Analog Input / Output	Analog Input	Total 2 channels (allocable) analog speed override input(-10[V] ~ +10[V]) analog torque command input(-10[V] ~ +10[V])									
	Analog Output	Total 2 channels 15 function inputs can be selectively allocated									
USB Communication	Functions	Firmware download, parameter setting, tuning, auxiliary function, parameter copy									
	Communication Specifications	Complies with USB 2.0 Full speed specifications									
	Connection Device	PC or USB storage media									
Built-in Functions	Dynamic Braking	Standard built-in(inactivated by servo alarm or servo OFF)									
	Regenerative Braking	Default built-in(Excluding 15kW), external installation possible									
	Display	7-segment display (5 digits)									
	Self-setting Function	Drive node address can be set using rotary switch									
	Additional Function	Gain tuning, alarm history, JOG operation, origin search									
	Protective Function	Excessive current, overload, excessive current limit, overheating, excessive voltage, low voltage, excessive speed, encoder failure, position following failure, current sensing failure									
Operation Environment	Operating Temperature / Storage Temperature	0 ~ +50[°C] / -20 ~ +70[°C]									
	Operating Humidity / Storage Humidity	Below 80[%]RH / Below 90[%]RH(Noncondensing)									
	Environment	Keep indoors. Avoid corrosive / flammable gas or liquid, and electrically conductive dust.									

L7PB Drive

Item	Type Name	L7PB010U	L7PB020U	L7PB035U	L7PB050U	L7PB075U	L7PB150U
Input Power	Main Power Supply	3 Phase AC380 ~ 480[V](-15 ~ +10[%]), 50 ~ 60[Hz]					
	Control Power Supply	Single Phase AC380 ~ 480[V](-15 ~ +10[%]), 50 ~ 60[Hz]					
Rated Current[A]		3.7	8.0	10.1	17.5	22.8	39.0
Peak Current[A]		11.1	24.0	30.3	47.3	57.0	97.5
Encoder Type		Quadrature(Incremental), BiSS-B, BiSS-C(Absolute, Incremental), Tamagawa Serial(Absolute, Incremental), Panasonic Serial(Absolute), EnDat 2.2, Sinusoidal, Analog Hall					
Control Performance	Speed Control Range	Maximum 1: 5000					
	Frequency Response	Maximum 1 [kHz] or above (When using 19bit Serial Encoder)					
	Speed Variation Ratio	± 0.01 [%] or lower [when load changes between 0 and 100%] ± 0.1 [%] or lower [temperature 25 $\pm 10^{\circ}\text{C}$]					
	Accel/Decel Time	Straight or S-curve acceleration/deceleration [0~10,000[ms], 0~1,000[ms] Unit configurable]					
	Input Frequency	1[Mpps], line drive / 200[kpps], Open collector					
	Input Pulse Type	Symbol + Pulse Series, CW+CCW, A/B Phase					
RS422 Communication Specifications	Communication Specifications	ANSI/TIA/EIA-422 Standard specifications					
	Communication Protocol	MODBUS-RTU					
	Connector	RJ45 x 2					
	Synchro Method	Asynchronous					
	Transmission Speed	9600 / 19200 / 38400 / 57600 [bps], Can be configured at [0x3002]					
	Transmission Distance	Maximum 200 [m]					
	Power Consumption	100[mA]					
	Terminating Resistance	Dip S/W(On/Off), Built-In 120 Ω					
Digital Input, Output	Digital Input	Input voltage range: DC 12[V] ~ DC 24[V], total 16 input channel (allocable), 30 function inputs can be selectively allocated (*SV_ON, *POT, *NOT, *A-RST, *START, *STOP, *REGT, *EMG, *HOME, *HSTART, *ISEL0, *ISEL1, *ISEL2, *ISEL3, *ISEL4, *ISEL5, PCON, GAIN2, P_CL, N_CL, PAUSE, ABSRQ, JSTART, JDIR, PCLR, SPD1/LVSF1, SPD2/LVSF2, SPD3, AOV, MODE)					
	Digital Output	Use rating: DC 24[V] $\pm 10\%$, 120[mA], total 8 input channel (allocable) 19 function inputs can be selectively allocated (*ALARM \pm , *READY \pm , *BRAKE \pm , *INPOS1 \pm , *ORG \pm , *EOS \pm , *TGON \pm , *TLMT \pm , VLMT \pm , INSPD \pm , ZSPD \pm , WARN \pm , INPOS2 \pm , IOU0 \pm , IOU1 \pm , IOU2 \pm , IOU3 \pm , IOU4 \pm , IOU5 \pm)					
Analog Input / output	Analog Input	Total 2 channels Analog speed override input (command / override) -10[V] ~ +10[V], Analog torque command input (command / limit) -10[V] ~ +10[V]					
	Analog Output	Total 2 channels (allocable) 15 function inputs can be selectively allocated					
USB Communication	Functions	Firmware download, parameter setting, tuning, auxiliary function, parameter copy					
	Communication Specifications	Complies with USB 2.0 Full speed specifications					
	Connection Device	PC or USB storage media					
Built-in Functions	Dynamic Braking	Standard built-in(Activated by servo alarm or servo OFF)					
	Regenerative Braking	Default built-in(Excluding 15kW), external installation possible					
	Display	7-segment display (5 digits)					
	Self-setting Function	Drive node address can be set using rotary switch					
	Additional Function	Gain tuning, alarm history, JOG operation, origin search					
	Protective Function	Excessive current, overload, excessive current limit, overheating, excessive voltage, low voltage, excessive speed, encoder failure, position following failure, current sensing failure					
Operation Environment	Operating Temperature / Storage Temperature	0 ~ +50[$^{\circ}\text{C}$] / -20 ~ +70[$^{\circ}\text{C}$]					
	Operating Humidity / Storage Humidity	Below 80[%]RH / Below 90[%]RH(Noncondensing)					
	Environment	Keep indoors. Avoid corrosive / flammable gas or liquid, and electrically conductive dust.					

*Unit [mm]

L7PA001U ~ L7PA004U
 [Weight: 1.0kg]

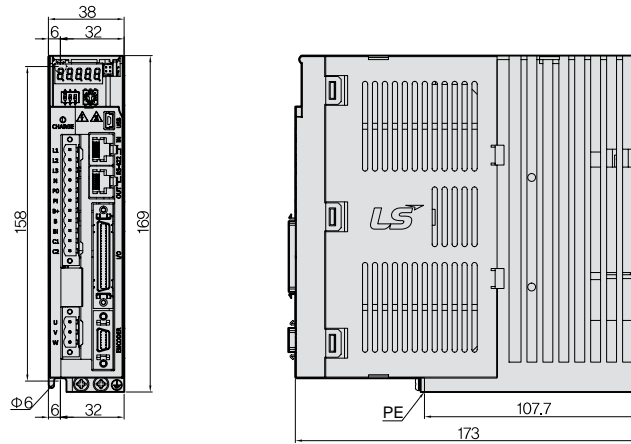

*Unit [mm]

L7PA008U / L7PA010U
 [Weight: 1.5kg
 (Fan-Cooling included)]

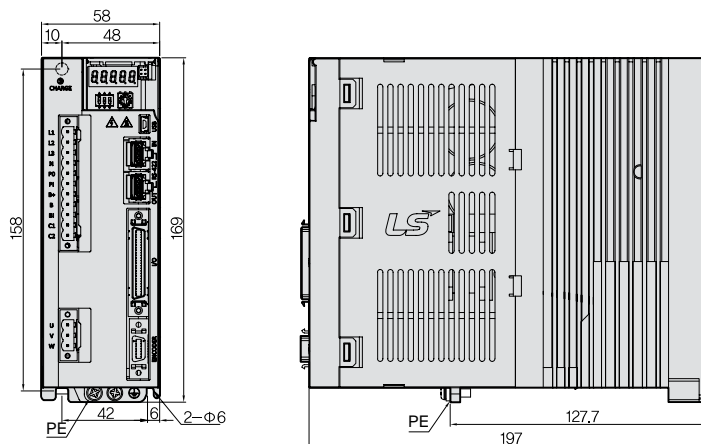

*Unit [mm]

L7PA020U / L7PA035U
 [Weight: 2.5kg
 (Fan-Cooling included)]

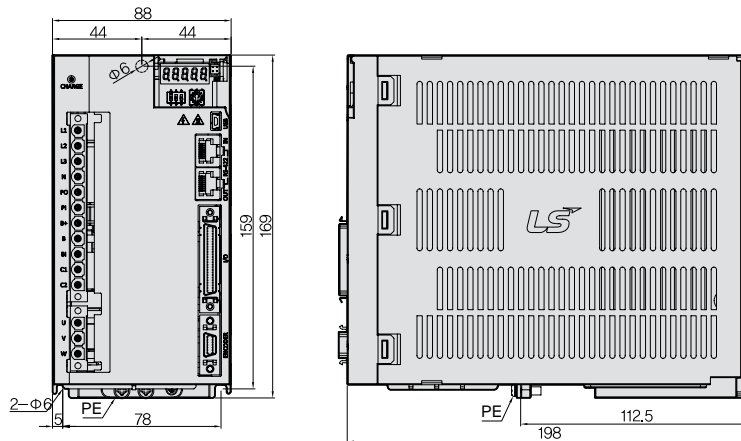

*Unit [mm]

L7PA050U

[Weight: 5.5kg
[Fan-Cooling included]]

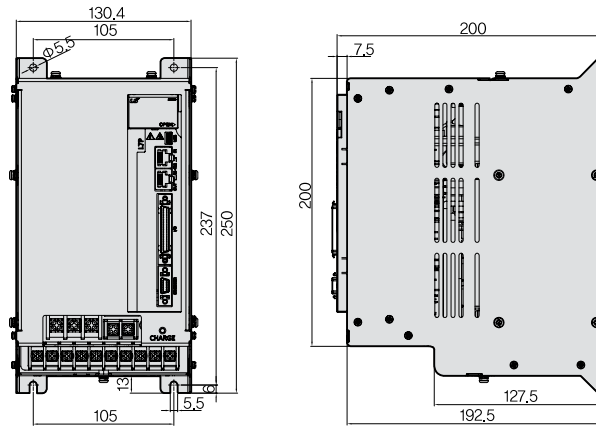

*Unit [mm]

L7PA075U

[Weight: 8.5kg
[Fan-Cooling included]]

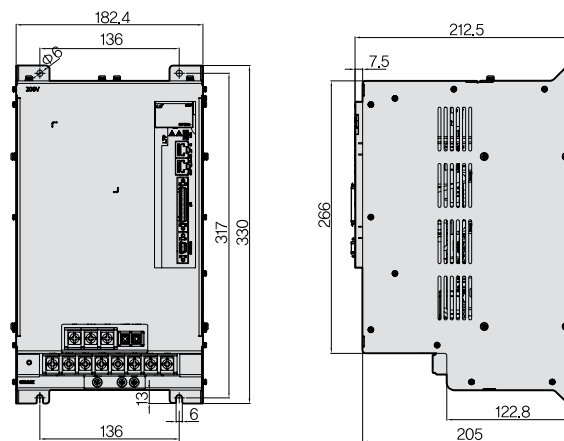

*Unit [mm]

L7PA150U

[Weight: 16.2kg
[Fan-Cooling included]]

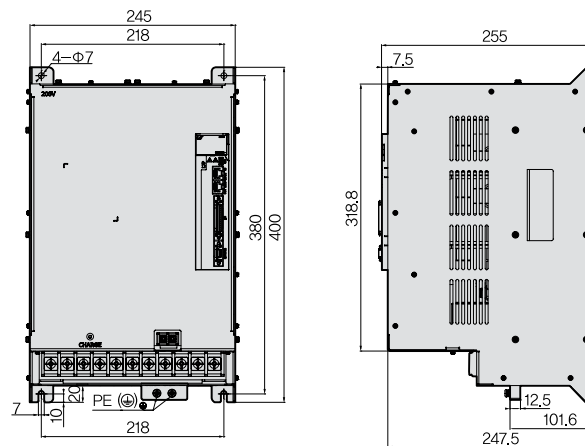

*Unit [mm]

L7PB010U

[Weight: 1.5kg
[Fan-Cooling included]]

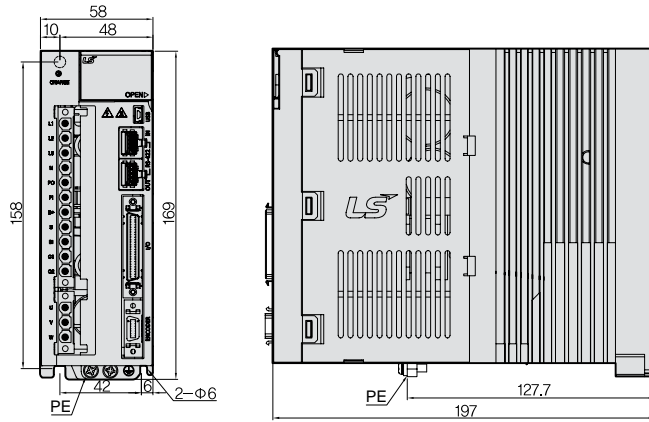

*Unit [mm]

L7PB020U / L7PB035U

[Weight: 2.5kg
[Fan-Cooling included]]

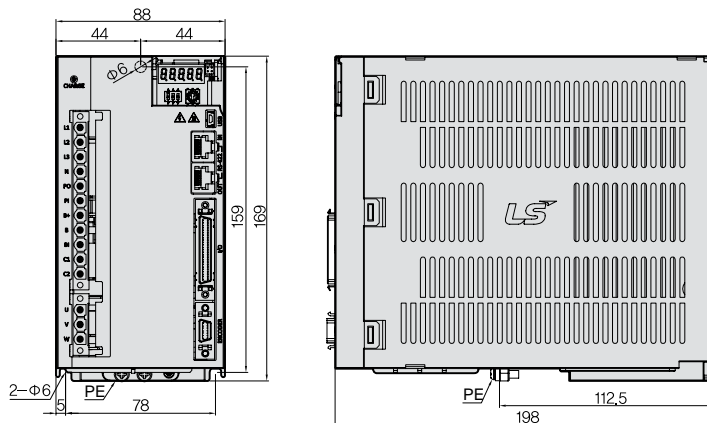

*Unit [mm]

L7PB050U

[Weight: 5.5kg
[Fan-Cooling included]]

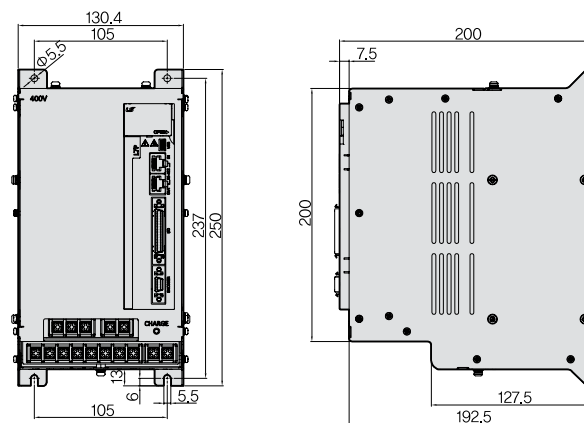

*Unit [mm]

L7PB075U

[Weight: 8.5kg
[Fan-Cooling included]]

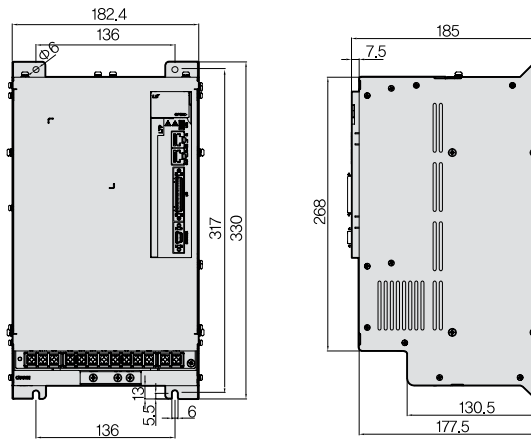

*Unit [mm]

L7PB150U

[Weight: 15.5kg
[Fan-Cooling included]]

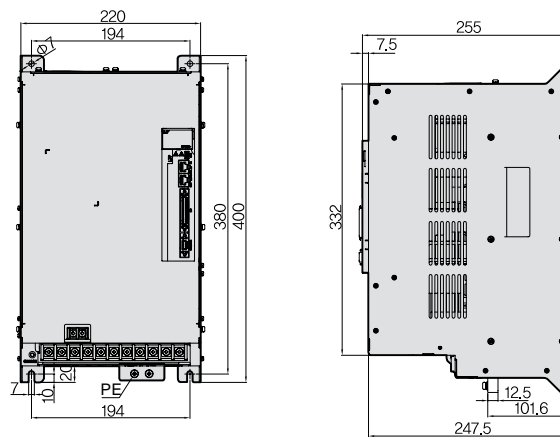

PEGA Series



Servo Drive Designation

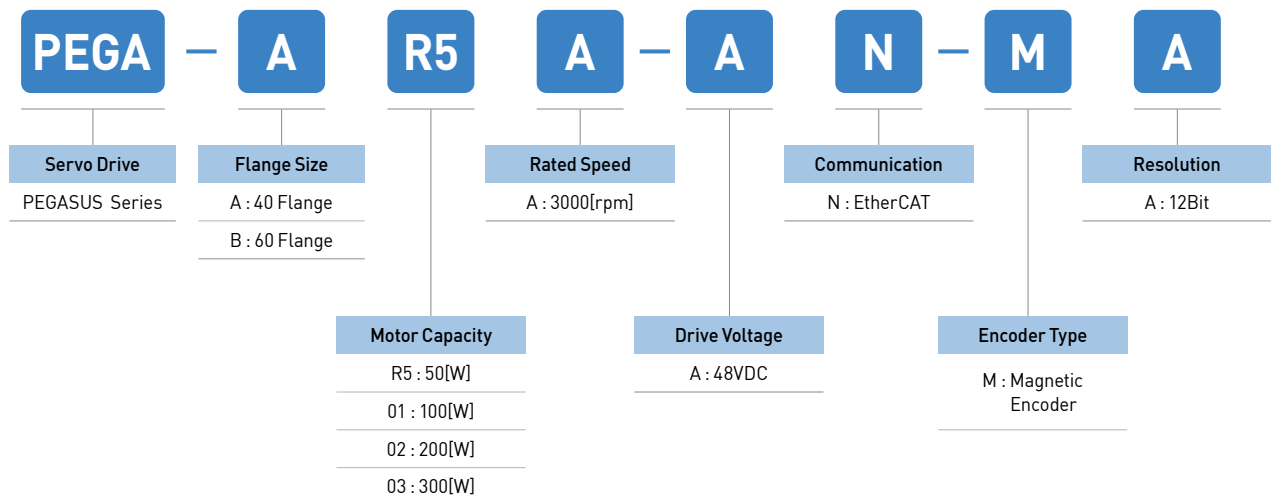

Integrated Drive-Motor EtherCAT Type **PEGA**

Enhanced Efficiency Through Integration of Motor and Drive

- Cost effective from installation by integrated system of motor, encoder cable and drive
- Highly efficient space usage when installed at limited and small space
- High effectiveness for application of multi axis because there is no limitation for space of installation

Real-time Control Through EtherCAT

- High speed, Real-time capability and synchronization mechanism
- Improved EtherCAT communication speed (min. 250µs, supports DC)
- Supports CoE, EoE and FoE

- 1 Input / Output signal connector (CN1)
 - This connector is for sequence input / Output signals
- 2 EtherCAT Communication output port (OUT)
- 3 Status LED
- 4 Power connector (CN3)
- 5 EtherCAT Communication input port (IN)
- 6 Safety connector (CN2)
 - This connector connects safety devices
- 7 USB Connector (CN5, Mini B type)
 - This connector is to communicate with a PC
- 8 Node address setting switch
 - This switch is to set the node address of the drive
 - You can set the node addresses from 0 to 15

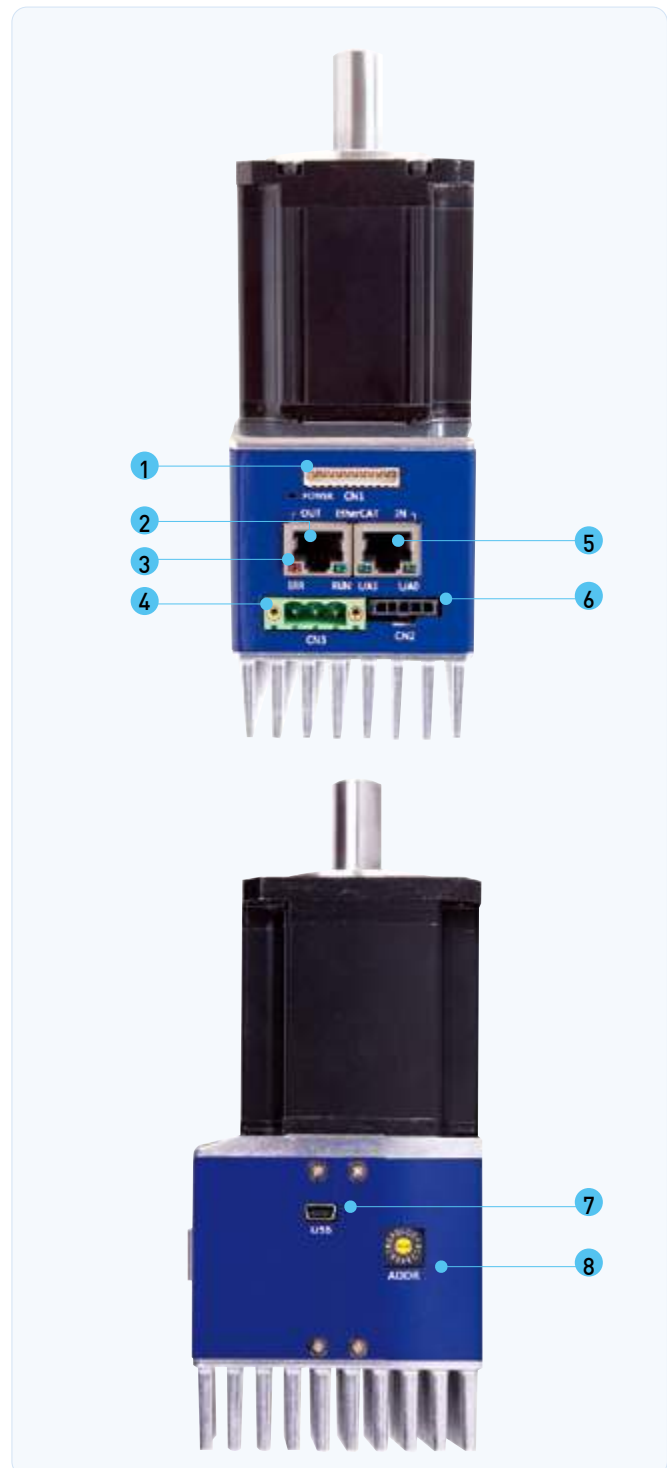

Rated Values of Servo Drive

Rated	□40 50W (AR5A)	□40 100W (A01A)	□60 100W (B01A)	□60 200W (B02A)	□60 300W (B03A)
Continuous Output Current [Arms]	1.8	2.4	3.6	5.0	6.8
Maximum Output Current [Arms]	3.5	3.8	7.2	10.0	13.6
Input Voltage	DC 48V ~ DC 60V				

Basic Specifications

Category		Details	
Use Conditions	Control Method	PWM controlled sine wave current driving method	
	Operating Temperature/Storage Temperature	0~+40[°C] / -20~ +60[°C]	
	Operating Humidity/Storage Humidity	Below 80% RH / Below 90% RH (no freeze or condensation)	
	Vibration-/Impact-resistance	TBD	
	Degree of Protection/Degree of Pollution	TBD	
	Altitude	1000m or lower	
	Other	To be free from electrostatic noise, strong electric current, or radiation.	
Performance	Speed Variation	Load Variation	At 0 to 100% load: ± 3% (at rated speed)
		Voltage Variation	Rated voltage ±10%: 0% (at rated speed)
		Temperature Variation	25°C: ±0.1% or less (at rated speed)
Input/Output Signal	Input Signal	Input voltage range: DC 12V - DC 30V The 4-channel input signal can be assigned to 12 functions: POT, NOT, HOME, STOP, PCON, GAIN2, PCL, NCL, PROBE1, PROBE2, EMG, and ARST.	
	Output Signal	Rated voltage and current: DC 24V ±10%, 120[mA] The 2-channel output signal can be assigned to 11 functions: BRAKE, ALARM, RDY, ZSPD, INPOS1, TLMT, VLMT, INSPD, WARN, TGON, and INPOS2.	
Analog Monitor		Number of channels: 1, Output voltage range: ±4V, Angular resolution: 12 bits, Stabilization time: 15 us	
USB Communication	Connecting Device	PC or USB storage medium	
	Communication Standard	Conforms to the USB 2.0 Full Speed Standard.	
	Function	Firmware download, parameter setting, adjustment, auxiliary functions, and parameter copy function.	
Dynamic Brake (Three-phase Short-circuit)		Activates when servo alarm, servo OFF, or Emergency stop (POT, NOT and EMG) is input.	
Protection Functions		Overcurrent, overload, current limit, overheat, overvoltage, undervoltage, overspeed, encoder error, position follow error, etc.	
Auxiliary Functions		Gain adjustment, alarm history, JOG drive, programmed JOG drive, etc.	
Safety Functions	Input	ST01, ST02	
	Compatible Standard	TBD	

EtherCAT Communication Specification

Category		Details
Communication Standard	FoE	Firmware download
	EoE	Parameter setting, adjustment, auxiliary functions, and parameter copy through UDP.
	CoE	IEC 61158 Type12, IEC 61800-7 CiA 402 drive profile
Physical Layer		100BASE-TX(IEEE802.3)
Connector		RJ45 x 2
Distance		Within 100 m between nodes
DC (Distributed Clock)		Sync by DC mode
LED Display		• L/A0(Link/Act IN) • L/A1(Link/Act OUT) • RUN • ERR
Cia402 Drive Profile		Supports CSP, CSV, CST, PP, PV, PT, and HM Modes.

Internal Encoder Specification

Category	Details
Encoder Type	Magnetic Encoder (12bit)(Singleturn Absolute)

Internal Motor Specification

Model	□40 50W (AR5A)	□40 100W (A01A)	□60 100W (B01A)	□60 200W (B02A)	□60 300W (B03A)	
Rated Torque	[N·m]	0.16	0.32	0.32	0.64	1.27
	[kgf·cm]	1.62	3.25	3.25	6.50	9.74
Max. Torque	[N·m]	0.32	0.48	0.64	1.27	1.91
	[kgf·cm]	3.24	4.88	6.50	13.0	19.48
Rated Speed	[r/min]	3000	2400	3000	3000	3000
Max Speed	[r/min]	3000	3000	3000	3000	3000
Inertia	[kg·m ² X10 ⁻⁴]	0.0240	0.0450	0.1140	0.1820	0.3210
	[gf·cm·s ²]	0.0245	0.0459	0.1163	0.1857	0.3276

Speed-Torque Characteristics

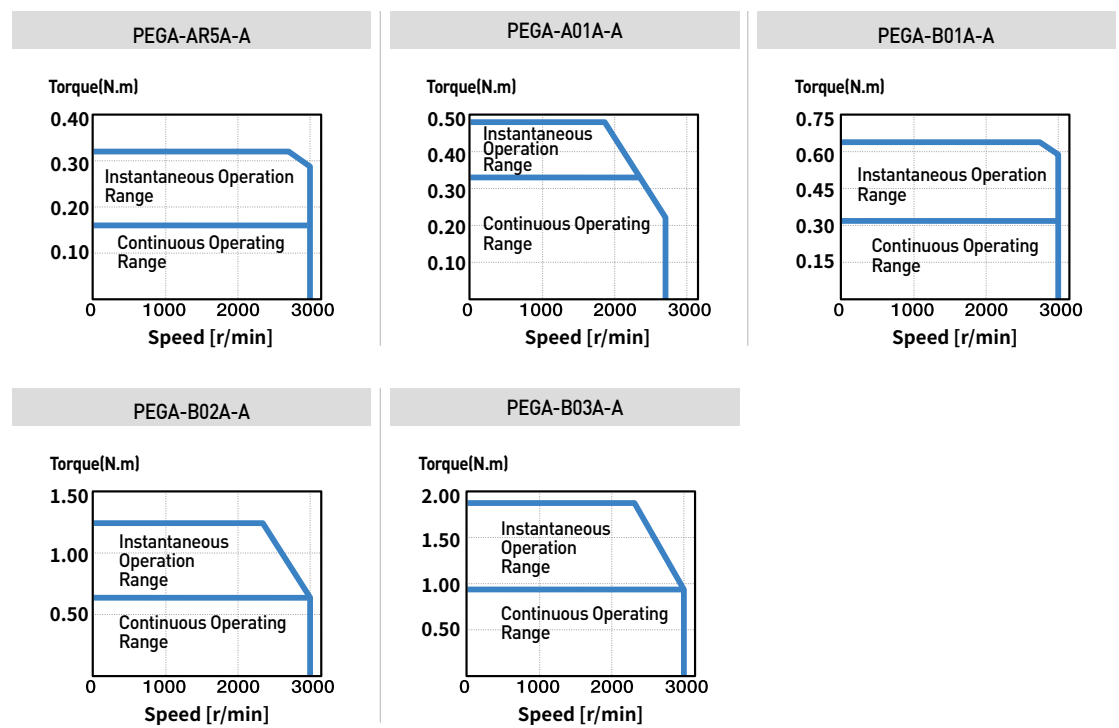

*Unit [mm]

PEGA-AR5A

[Weight: 0.51kg]

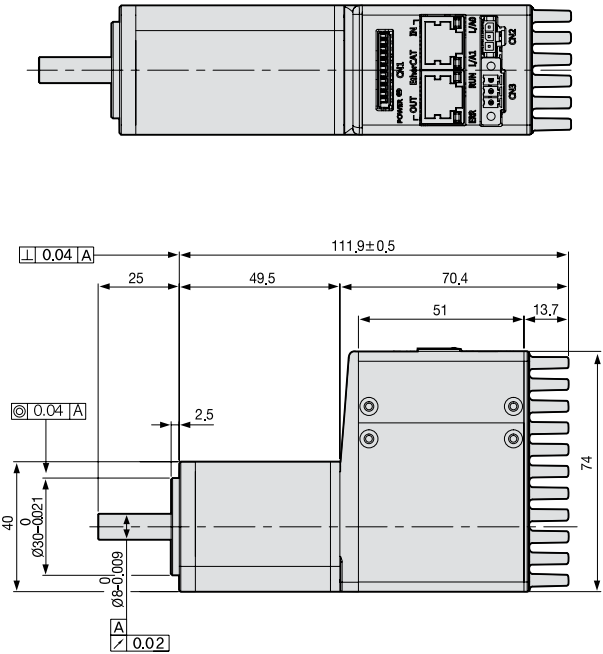
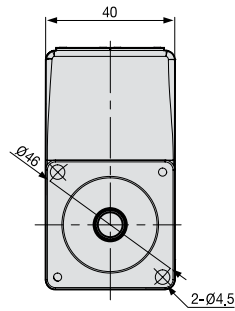
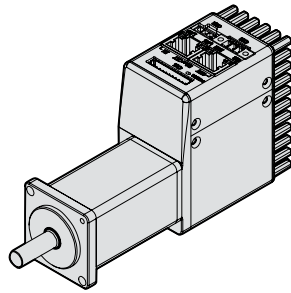

*Unit [mm]

PEGA-A01A

[Weight: 0.63kg]

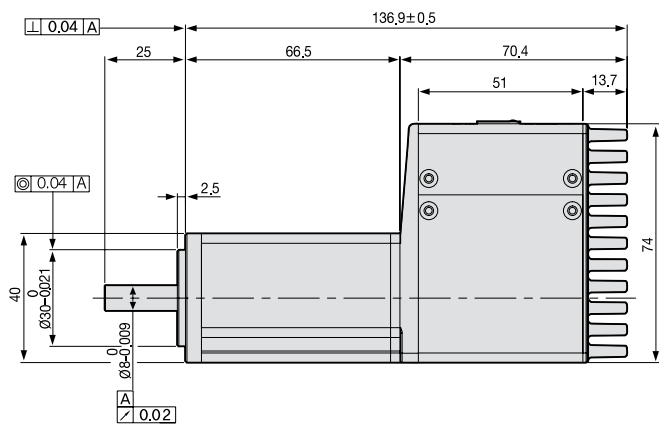
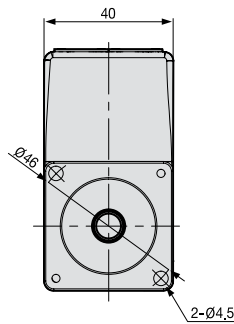
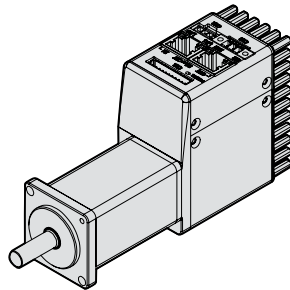

*Unit [mm]

PEGA-B01A
[Weight: 1.07kg]

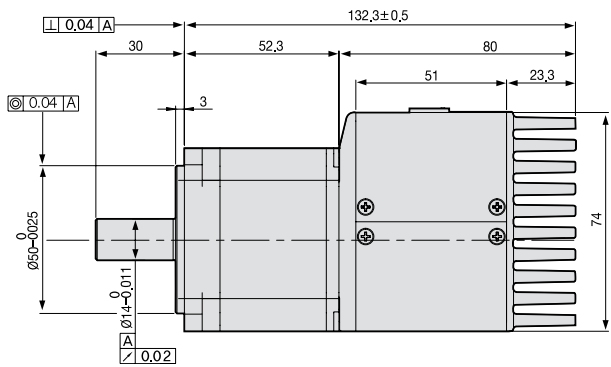
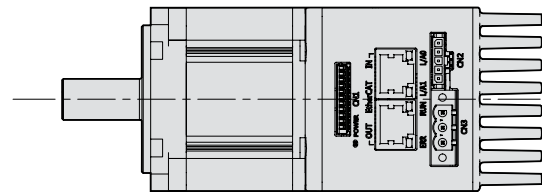
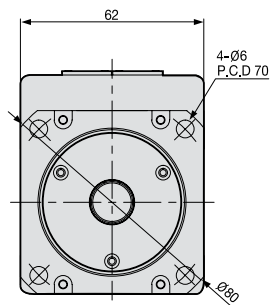
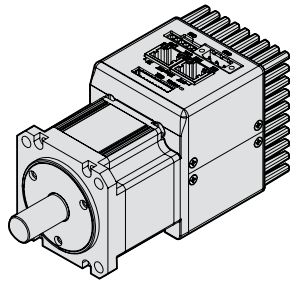

Servo Drive

*Unit [mm]

PEGA-B02A
[Weight: 1.30kg]

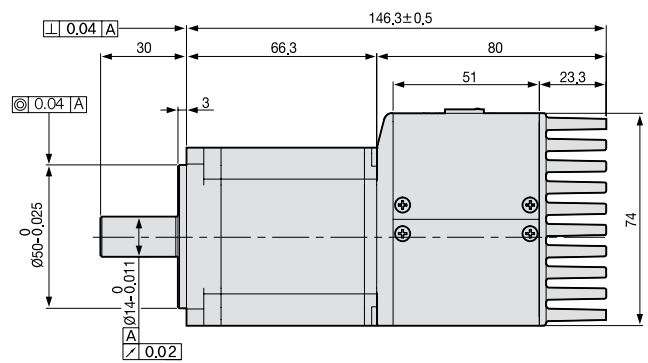
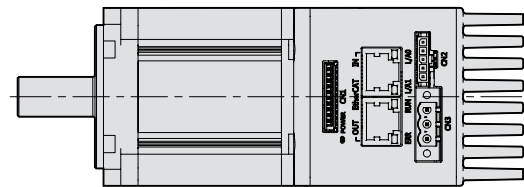
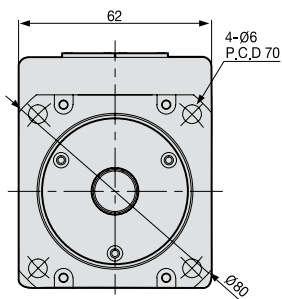
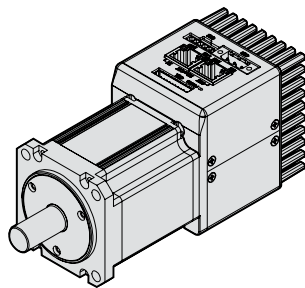

PEGA-B03A

[Weight: 1.79kg]

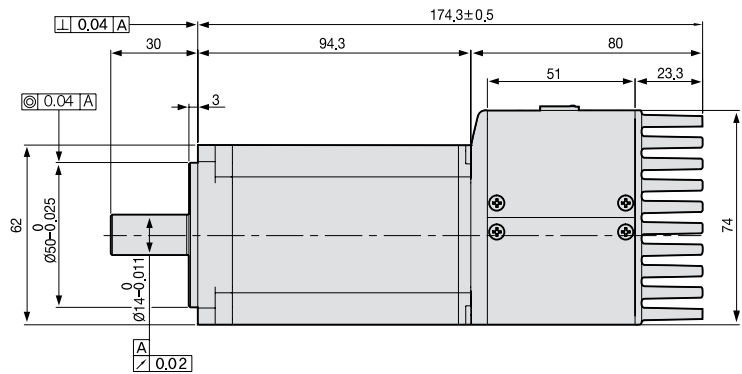
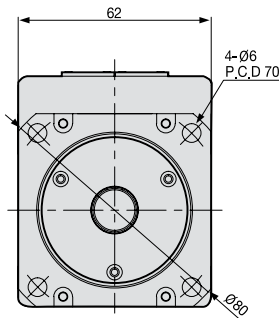
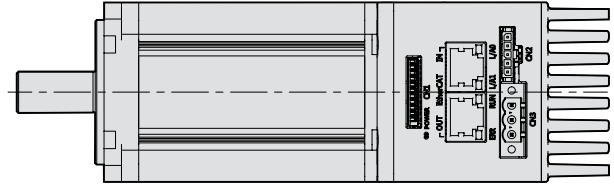
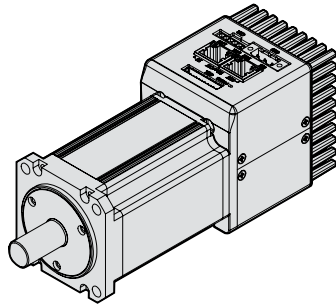

Accessory Kit

CN1 : I/O Connector

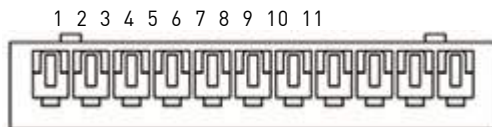

51004-1100(MOLEX)

Pin No.	Direction	Name	Signals	Descriptions
1	VCC	+24	+24V INPUT	+24V Vcc Input
2	Input	POT	Positive Over-Travel	Limit Sensor Input
3	Input	NOT	Negative Over-Travel	
4	Input	HOME	Home Sensor	Home Sensor Input for Homing
5	Input	STOP	Stop Input	Stop Command Input
6	Output	BRAKE+	BRAKE	Output Brake Control Signal
7	Output	BRAKE-		
8	Output	ALARM+	Alarm Output	Servo Alarm Output
9	Output	ALARM-		
10	Output	MONITOR1	Analog Monitor	Analog Monitor Output(0V-5V)
11	GND	AGND	AGND(0V)	Analog Signal Ground

CN2 : Safe Torque Off Connector

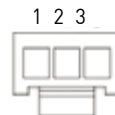

43645-3(MOLEX)

Pin No.	Name	Descriptions
1	HWBB1	Safe Torque Off(STO) input signals
2	HWBB2	
3	COMMON	DC 24V GND

CN3 : Power Connector

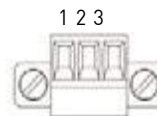

MC_1.5-3-STF-3.5
(PHOENIX CONTACT)

Pin No.	Name	Descriptions
1	FG	Frame Ground
2	N(DC 0V)	DC 0V GND
3	VCC(DC 48V)	DC 48V input

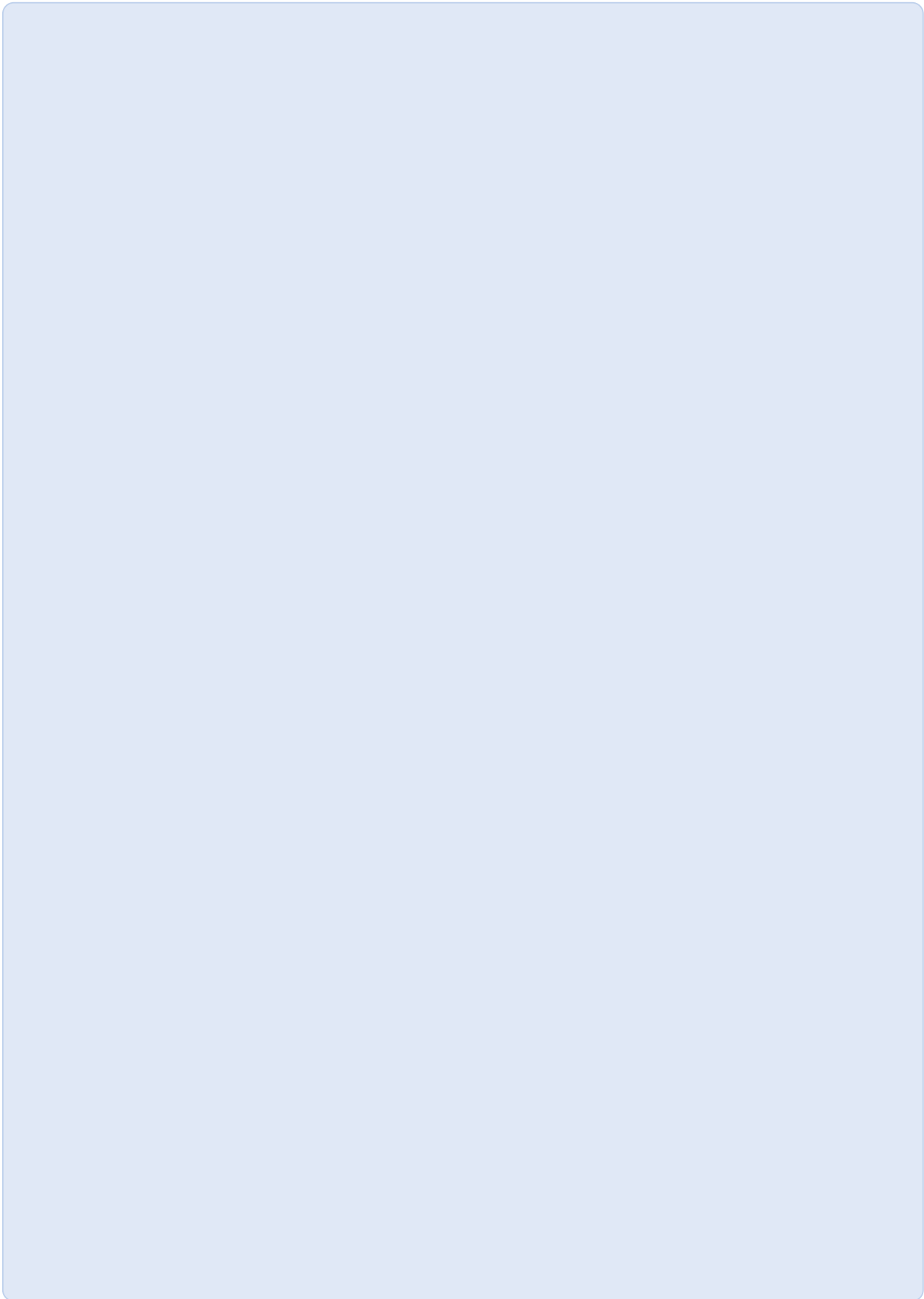

PHOX Series



Servo Drive Designation

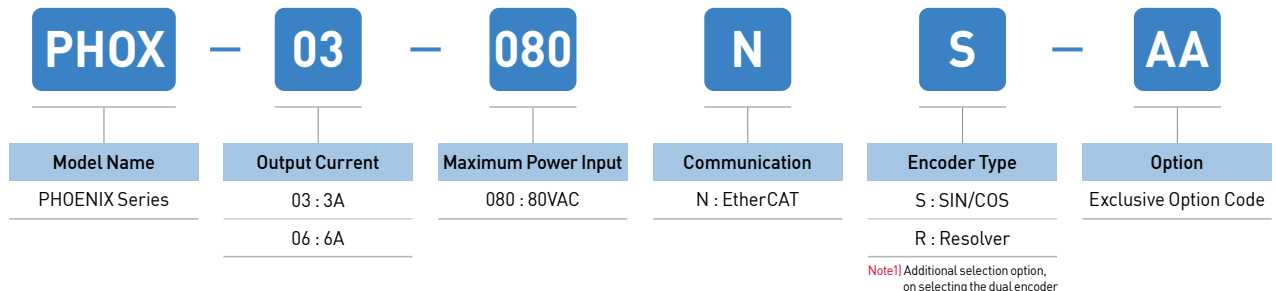

Low Voltage DC Drive Type **PHOX**

Real-time Control Through EtherCAT

- High speed, Real-time capability and synchronization mechanism
- Supports CoE, EoE and FoE
- Improved frequency response($\approx 1\text{kHz}$)
- Improved communication speed by applying 16bit-bus
 - Improved chip communication speed
 - Improved EtherCAT communication speed

Variable Switching Frequency

- 16/32/48kHz

Fully-closed Loop Control

- Switch among Semi-closed loop control, Fully-closed loop control and dual feedback control
- Fully-closed loop control provides quick response with internal and external encoder position values
- Fully-closed loop control ensures high-precision control during machine operation

Programming Function Including Single-axis Position Module

- Positioning control mode with pulse inputs
- Provides position control through I/O or HMI without position control module
- Supports indexing mode

- 1 EtherCAT Out
- 2 EtherCAT In
- 3 Switch for node address setting
- 4 Mini B USB
- 5 STO Connector
- 6 IO Connector
- 7 Encoder B connector
- 8 Encoder A connector
- 9 Status LED
- 10 Brake connector
- 11 Motor power connector
- 12 Master power connector(HV+,HV-)
- 13 Auxiliary power connector[AUX+,AUX-]
- 14 Ground

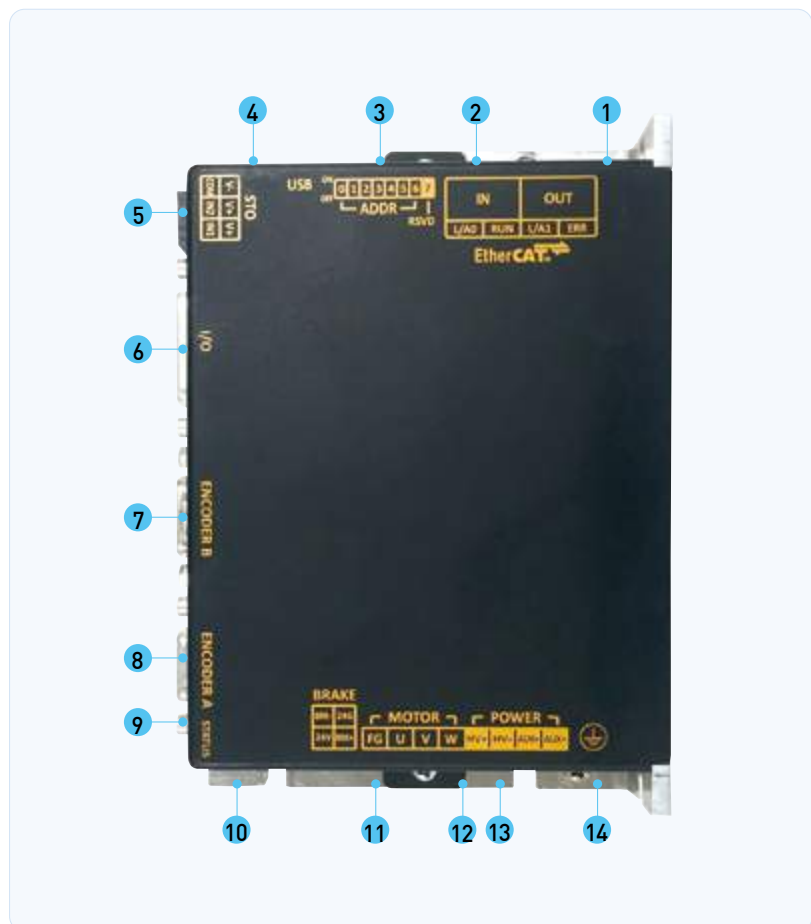

PHOX Series

Item		Type Name	PHOX-03	PHOX-06
Input Power	Main Power Supply		DC 24~80[V] ^{Note1}	
	Control Power Supply		DC 24~80[V] ^{Note1}	
Rated Current[A]			3	6
Peak Current[A]			9[A] > 1[sec]	18[A] > 1[sec]
1st Encoder Encoder A			*Quadrature(Max. 10Mpps after X 4) - With and without halls, Differential *Serial Encoder(absolute, incremental) - BiSS(B,C), Endat2.2, Tamagawa Serial, SSI	
2nd Encoder ^{Note2} Encoder B			*Quadrature(Max. 10Mpps after X 4) - Without halls, Differential *Serial Encoder(absolute, incremental) - BiSS(B,C), Endat2.2, Tamagawa Serial, SSI *Analog Encoder - Sinusoidal(1Vpp), Analog hall(Sin/Cos) - Resolver(Optional)	
Control Performance	Speed Control Range		Maximum 1: 5000	
	Frequency Response		Maximum 1 [kHz] or above (When using 19bit Serial Encoder)	
	Speed Variation Ratio		±0.01 [%] or lower [when load changes between 0 and 100%] ±0.1[%] or lower [temperature 25 ±10°C]	
	Accel / Decel Time		Within ±1%	
	Input Frequency		4[Mpps], line drive	
	Input Pulse Method		Symbol+Pulse series, CW+CCW, PhaseA/B	
EtherCAT Communication Specifications	Communication Standard		FoE (Firmware download) EoE (Parameter setting by UDP, Tuning, Secondary function, Parameter copy) CoE (IEC 61158 Type12, IEC 61800-7 CIA 402 Drive profile)	
	Physical Layer		100BASE-TX(IEEE802.3)	
	Connector		RJ45 x 2	
	Communication distance		Within connection between nodes 100[m]	
	DC(Distributed Clock)		Synchronization by DC mode, minimum DC cycle: 250[μs]	
	LED Display		LinkAct IN, LinkAct OUT, RUN, ERR	
	Cia402 Drive Profile		Profile Position Mode, Profile Velocity Mode, Profile Torque Mode, Cyclic Synchronous Position Mode Cyclic Synchronous Velocity Mode, Cyclic Synchronous Torque Mode, Homing Mode	
Digital Input, Output	Digital Input		Total 4 input channels(Allocable) Total 33 functions can be used selectively for assignment (*POT, *NOT, *HOME, *STOP, PCON, GAIN2, P_CL, N_CL, PROBE1P, ROBE2, EMG, A_RST, SV_ON, START, PAUSE, REGT, HSTART, ISEL0-5, ABS_RQ, JSTART, JDIR, PCLR, AOVR, INHIB, SPD1, SPD2, SPD3, MODE)	
	Digital Output		Total 4 input channels(Allocable) Total 33 functions can be used selectively for assignment (*BRAKE, *ALARM, *READY, *ZSPD, INPOS1, INPOS2, TLMT, VLMT, INSPD, WARN, TGON, ORG, EOS, IOUT0, IOUT1, IOUT2, IOUT3, IOUT4, IOUT5)	
Analog Input / Output	Analog Input		Input voltage range: ±10[V] differential Single channel, torque limit value adjustable through analog voltage	
	Analog Output		Total 2 channels(allocable) Total 15 outputs can be used selectively for assignment	
Safety Function			2 input channels(STO1, STO2)	
Encoder Output Type			A0(+/-), B0(+/-), Z0(+/-) (Line drive output max. 6.4Mpps)	
USB Communication	Function		Firmware download, parameter setting, tuning, auxiliary function, parameter copy	
	Communication Standard		Complies with USB 2.0 Full speed specifications	
	Connect		PC or USB storage media	
Internal Function	Self-setting Function		Drive node address can be set using dip switch	
	Additional Function		Gain tuning, alarm history, JOG operation, origin search	
	Protective Function		Overcurrent, overload, excessive current limit, overheat, overvoltage, undervoltage, overspeed, encoder error, position following error, current sensing error	
Operation Environment	Operating Temperature / Storage Temperature		0 ~ 50[°C] / -20 ~ 65 °C	
	Operating Humidity / Storage Humidity		Below 80[%]RH / Below 90[%]RH(Noncondensing)	
	Environment		Keep indoors. Avoid corrosive / flammable gas or liquid, and electrically conductive dust.	

^{Note1} It is possible to drive with a voltage of less than 48 [V] of DC input power. However, the actual speed may be slower than the command speed and the specifications of the low voltage motor [based on DC 48 [V]] cannot be guaranteed. We recommend using DC 48[V] as the input power if possible.

^{Note2} Available when full-closed function is applied

PHOX Series I/O and Encoder PIN Map

I/O Connector
10090769-P264ALF

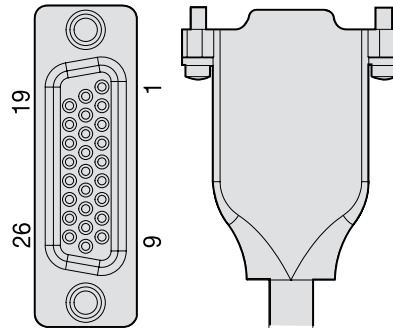

PIN No.	Signal	PIN No.	Signal	PIN No.	Signal	PIN No.	Signal
1	PF+	8	AMON1	15	D01	22	/B0
2	PF-	9	AMON2	16	D02	23	Z0
3	PR+	10	DICOM	17	D03	24	/Z0
4	PR-	11	DI1	18	18 D04	25	DOCOM
5	AGND	12	DI2	19	A0	26	AGND
6	AI+	13	DI3	20	/A0		
7	AI-	14	DI4	21	B0		

Encoder A Connector
10090769-P154ALF

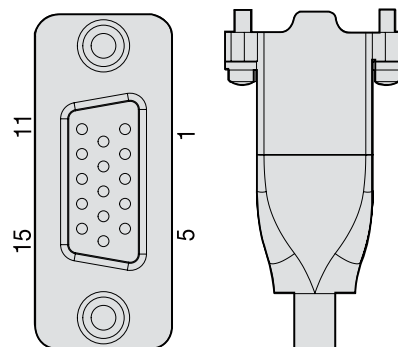

PIN No.	Encoder				
	Quad	BISS	SSI	ENDAT	TAMAGAWA
1	Z+	-	-	-	-
2	Z-	-	-	-	-
3	GND	GND	GND	GND	GND
4	-	-	-	-	-
5	5V	5V	5V	5V	5V
6	GND	GND	GND	GND	GND
7	A-	SL-	DATA-	RC-/DV-	TXD-/RXD-
8	A+	SL+	DATA+	RC+/DV+	TXD-/RXD+
9	HALL U	-	-	-	-
10	*MOT	*MOT	*MOT	*MOT	*MOT
11	B-	MA-	CLK-	CLK-	-
12	B+	MA+	CLK+	CLK+	-
13	HALL V	-	-	-	-
14	HALL W	-	-	-	-
15	-	-	-	-	-

PHOX Series I/O and Encoder PIN Map

Encoder B Connector (Full Closed)

10090770-S154ALF

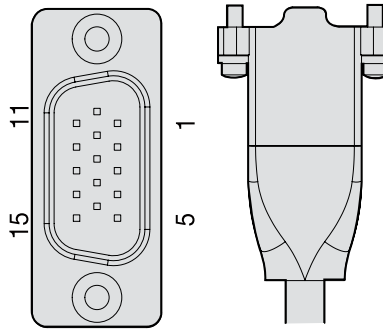

PIN No.	Encoder						
	Quad	BISS	SSI	ENDAT	TAMAGAWA	SIN/COS	RESOLVER
1	Z+	-	-	-	-	-	-
2	Z-	-	-	-	-	-	-
3	GND	GND	GND	GND	GND	GND	GND
4	-	-	-	-	-	SIN+	SIN+
5	5V	5V	5V	5V	5V	5V	5V
6	-	-	-	-	-	REF-	EXT-
7	A-	SL-	DATA-	RC-/DV-	TXD-/RXD-	-	-
8	A+	SL+	DATA+	RC+/DV+	TXD+/RXD+	-	-
9	-	-	-	-	-	SIN-	SIN-
10	*MOT	*MOT	*MOT	*MOT	*MOT	*MOT	*MOT
11	B-	MA-	CLK-	CLK-	-	-	-
12	B+	MA+	CLK+	CLK+	-	-	-
13	-	-	-	-	-	REF+	EXT+
14	-	-	-	-	-	COS-	COS-
15	-	-	-	-	-	COS+	COS+

STO Connector

IPD1-03-D-K

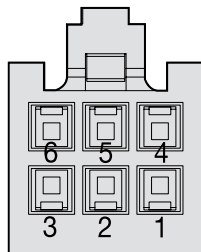

PIN No.	Signal	Description
1	COM	Common(24 GND)
2	STO2	Cuts off current(torque) applied to motor when signal is off
3	STO1	Cuts off current(torque) applied to motor when signal is off
4	V-	DC -12V(bypass)
5	V+	DC -12V(bypass)
6	V+	DC -12V(bypass)

BRAKE Connector

IPD1-02-D-K

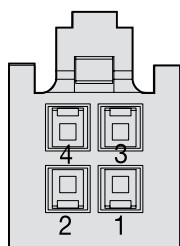

PIN No.	Signal	Description
1	24V	Brake 24V Input
2	BRK+	Brake 24V Output
3	BRK-	Brake (1A)
4	24G	24V Return

External Dimensions

*Unit [mm]

PHOX-03 / PHOX-06
[Weight: 0.43kg]

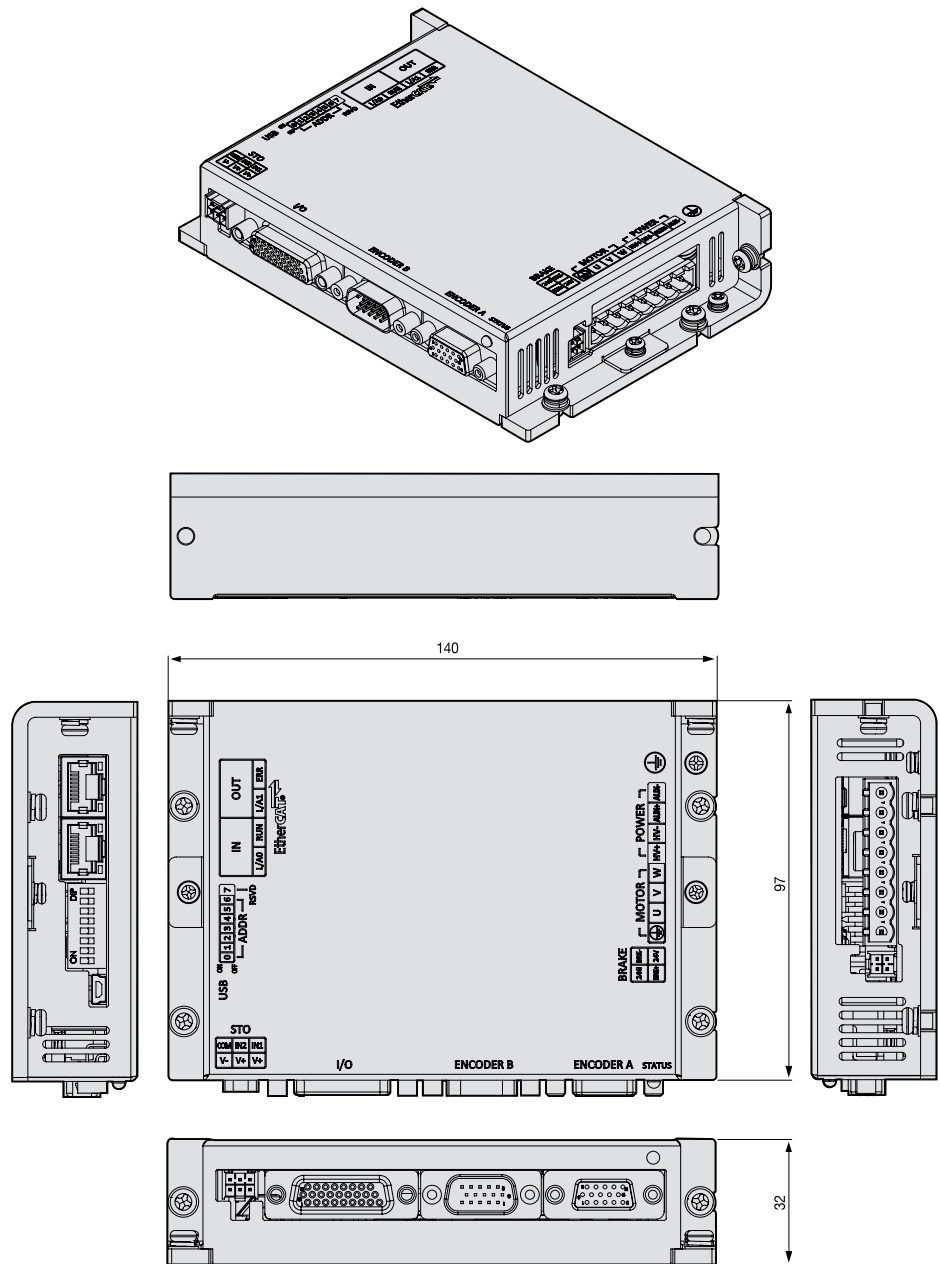

iX7M

Rated Speed (rpm)	Maximum Speed (rpm)	Flange	Motor	iX7 Drive	Encoder Cable		iX7 Power Cable	iX7 Power + Brake	Brake
					Serial	Absolute			
3,000	6,500	□40	EAR5A	iX7M-A-22□□B	APCS- E□□□RM-□b	APCS- E□□□RM1-□	APCS- P□□□EX1-□	'APCS- P□□□EBX1-□	-
		□40	EA01A	iX7M-A-22□□B					
	6,000	□40	EA015A	iX7M-A-22□□B					
		6,500	□60	EB01A			iX7M-A-22□□B		
	□60		EB02A	iX7M-A-22□□B					
	□60		EB04A	iX7M-A-44□□B					
	6000	□80	EC04A	iX7M-A-44□□B					
			EC06A	iX7M-A-88□□B					
			EC08A	iX7M-A-88□□B					
	5,500	□80	EC10A	iX7M-A-AA□□B					
3,000	5,000	□40	FALR5A	iX7M-A-22□□B	APCS- E□□□EM-□	APCS- E□□□EM1-□	APCS- P□□□LSX-□	-	APCSB □□□QS-□
		□40	FAL01A	iX7M-A-22□□B					
		□40	FAL015A	iX7M-A-44□□B					
		□60	FBL01A	iX7M-A-22□□B					
		□60	FBL02A	iX7M-A-22□□B					
		□60	FBL04A	iX7M-A-44□□B					
		□80	FCL04A	iX7M-A-44□□B					
		□80	FCL06A	iX7M-A-88□□B					
		□80	FCL08A	iX7M-A-88□□B					
		□80	FCL10A	iX7M-A-AA□□B					
200	500	135Φ	DB03D	iX7M-A-22□□B	APCS- E□□□ZM	-	APCSPN □□□YSX	-	-
			DB06D	iX7M-A-22□□B					
			DB09D	iX7M-A-44□□B					
	400	175Φ	DC06D	iX7M-A-22□□B					
			DC12D	iX7M-A-44□□B					
			DC18D	iX7M-A-88□□B					
	500	230Φ	DD12D	iX7M-A-44□□B					
			DD22D	iX7M-A-88□□B					
	DD34D		iX7M-A-AA□□B						
	300	290Φ	DE40D	iX7M-A-AA□□B					
200	500	135Φ	DFB03D	iX7M-A-22□□B	APCS- E□□□ZM1	-	APCSPN □□□YSX1	-	-
		175Φ	DFC06D	iX7M-A-22□□B					
		230Φ	DFD12D	iX7M-A-44□□B					

ix7NHA

Rated Speed (rpm)	Maximum Speed (rpm)	Flange	Motor	ix7 Drive	Encoder Cable		ix7 Power Cable	ix7 Power + Brake	Brake					
					Serial	Absolute								
3,000	5,000	□40	FALR5A	ix7NHA001U	APCS-E□□□ES-□	APCS-E□□□ES-□1	APCS-P□□□LSX	-	APCS-B□□□QS-□					
		□40	FAL01A	ix7NHA001U										
		□40	FAL015A	ix7NHA004U										
		□60	FBL01A	ix7NHA001U										
		□60	FBL02A	ix7NHA002U										
		□60	FBL04A	ix7NHA004U										
		□80	FCL04A	ix7NHA004U										
		□80	FCL06A	ix7NHA008U										
		□80	FCL08A	ix7NHA008U										
		□80	FCL10A	ix7NHA010U										
		□130	FE09A	ix7NHA010U						APCS-E□□□□DS	APCS-E□□□□DS1	APCS-P□□□HSX1	APCS-P□□□NBX1	-
		□130	FE15A	ix7NHA020U								APCS-P□□□HSX	APCS-P□□□NBX	
□130	FE22A	ix7NHA020U												
□130	FE30A	ix7NHA035U												
2,000	3,000	□130	FE06D	ix7NHA008U	APCS-E□□□□DS	APCS-E□□□□DS1	APCS-P□□□HSX1	APCS-P□□□NBX1	-					
		□130	FE11D	ix7NHA010U										
		□130	FE16D	ix7NHA020U			APCS-P□□□HSX	APCS-P□□□NBX						
		□130	FE22D	ix7NHA020U										
1,500	3,000	□130	FE05G	ix7NHA008U					APCS-P□□□HSX1	APCS-P□□□NBX1	-			
		□130	FE09G	ix7NHA010U					APCS-P□□□HSX	APCS-P□□□NBX				
		□130	FE13G	ix7NHA020U										
		□130	FE17G	ix7NHA020U										
1,000	2,000	□130	FE03M	ix7NHA004U					APCS-P□□□HSX1	APCS-P□□□NBX1	-			
		□130	FE06M	ix7NHA008U										
		□130	FE09M	ix7NHA010U										
		□130	FE12M	ix7NHA020U					APCS-P□□□HSX	APCS-P□□□NBX				

Servo Drive

ix7NHA DD Motor

Rated Speed (rpm)	Maximum Speed (rpm)	External Diameter Of Motor(Φ)	Motor	Drive	Encoder Cable		ix7 Power Cable	ix7 Power + Brake Cable	Brake				
					Serial	Absolute							
200	500	135Φ	DB03D	ix7NHA001U	APCS-E□□□□ZS	-	APCS-P□□□YSX	-	-				
			DB06D	ix7NHA002U									
			DB09D	ix7NHA004U									
		DC06D	ix7NHA002U										
		DC12D	ix7NHA004U										
		DC18D	ix7NHA008U										
	400	175Φ	DD12D	ix7NHA004U									
			DD22D	ix7NHA008U									
	400	230Φ	DD34D	ix7NHA010U									
			DE40D	ix7NHA010U									
300	290Φ	DE60D	ix7NHA020U										
		DFA1G	ix7NHA020U										
150	250	360Φ	DFA6G	ix7NHA035U			APCS-P□□□ZSX						
			DGC3S	ix7NHA020U									
200	500	135Φ	DFB03D	ix7NHA001U	APCS-E□□□□ZS1	-	APCS-P□□□YSX1	-	-				
		175Φ	DFC06D	ix7NHA002U									
		230Φ	DFD12D	ix7NHA004U									

L7NHA

Rated Speed (rpm)	Maximum Speed (rpm)	Flange	Motor	Drive	Encoder Cable		Power	Power + Brake	Brake						
					Serial	Absolute									
3,000	5,000	□40	FALR5A	L7NHA001U	APCS-E□□□ES-□	APCS-E□□□ES-□1	APCS-P□□□LS-□	-	APCS-B□□□QS-□						
		□40	FAL01A	L7NHA001U											
		□40	FAL015A	L7NHA004U											
		□60	FBL01A	L7NHA001U											
		□60	FBL02A	L7NHA002U											
		□60	FBL04A	L7NHA004U											
		□80	FCL04A	L7NHA004U											
		□80	FCL06A	L7NHA008U											
	2,000	3,000	□80	FCL05D	L7NHA008U	APCS-E□□□ES-□	APCS-E□□□ES-□1	APCS-P□□□LS-□	-	APCS-B□□□QS-□					
			□80	FCL06D	L7NHA008U										
			□80	FCL07D	L7NHA008U										
			□130	FE06D	L7NHA008U										
			□130	FE11D	L7NHA010U										
			□130	FE16D	L7NHA020U										
			□130	FE22D	L7NHA020U										
			□180	FF22D	L7NHA020U										
1,500	2,500	□180	FF35D	L7NHA035U	APCS-E□□□DS	APCS-E□□□DS1	APCS-P□□□HS1	APCS-P□□□NB1	-						
		□180	FF55D	L7NHA050U											
		□180	FF75D	L7NHA075U											
		□220	FG22D	L7NHA020U											
		□220	FG35D	L7NHA035U											
		□220	FG55D	L7NHA050U											
		□220	FG75D	L7NHA075U											
		□220	FG110D	L7NHA150U											
	1,000	2,000	□130	FE05G			L7NHA008U	APCS-P□□□HS1	APCS-P□□□NB1	APCS-P□□□HS	APCS-P□□□NB	-			
			□130	FE09G			L7NHA010U								
			□130	FE13G			L7NHA020U								
			□130	FE17G			L7NHA020U								
		1,700	2,000	□180			FF20G			L7NHA020U	APCS-P□□□IS1	APCS-P□□□PB1	APCS-P□□□IS	APCS-P□□□PB	-
				□180			FF30G			L7NHA035U					
				□180			FF44G			L7NHA050U					
				□180			FF60G			L7NHA075U					
1,000	2,000	□180	FF75G	L7NHA075U	APCS-P□□□JS	APCS-P□□□LB	APCS-P□□□JS2	APCS-P□□□LB2	-						
		□220	FG20G	L7NHA020U											
		□220	FG30G	L7NHA035U											
		□220	FG44G	L7NHA050U											
	2,000	2,000	□220	FG60G			L7NHA075U	APCS-P□□□MS	APCS-P□□□MS	APCS-P□□□VS	-	APCS-P□□□SB			
			□220	FG85G			L7NHA150U								
			□220	FG110G			L7NHA150U								
			□220	FG150G			L7NHA150U								

L7NHA DD Motor

Rated Speed (rpm)	Maximum Speed (rpm)	External Diameter Of Motor(Φ)	Motor	Drive	Encoder Cable		Power	Power + Brake	Brake
					Serial	Absolute			
200	500	135Φ	DB03D	L7NHA001U	APCS-E□□□ZS	-	APCS-PN□□□YS	-	-
			DB06D	L7NHA002U					
			DB09D	L7NHA004U					
	400	175Φ	DC06D	L7NHA002U					
			DC12D	L7NHA004U					
			DC18D	L7NHA008U					
	500	230Φ	DD12D	L7NHA004U					
			DD22D	L7NHA008U					
	400	230Φ	DD34D	L7NHA010U					
			300	290Φ					
		DE60D			L7NHA020U				
150	250	360Φ	DFA1G	L7NHA020U	APCS-PN□□□ZS				
			DFA6G	L7NHA035U					
50	100	380Φ	DGC3S	L7NHA020U					
200	500	135Φ	DFB03D	L7NHA001U	APCS-E□□□ZS1	-	APCS-PN□□□YS1	-	-
		175Φ	DFC06D	L7NHA002U					
		230Φ	DFD12D	L7NHA004U					

L7NHB

Rated Speed (rpm)	Maximum Speed (rpm)	Flange	Motor	Drive	Encoder Cable		Power	Power + Brake	Brake
					Serial	Absolute			
3,000	5,000	□130	FEP09A	L7NHB010U	APCS-E□□□DS	APCS-E□□□DS1	APCS-P□□□HS1	APCS-P□□□NB1	-
		□130	FEP15A	L7NHB020U					
		□130	FEP22A	L7NHB035U					
		□130	FEP30A	L7NHB035U					
		□180	FFP30A	L7NHB035U					
		□180	FFP50A	L7NHB050U					
2,000	3,000	□130	FEP06D	L7NHB010U					
		□130	FEP11D	L7NHB010U					
		□130	FEP16D	L7NHB020U					
		□130	FEP22D	L7NHB020U					
		□180	FFP22D	L7NHB020U					
		□180	FFP35D	L7NHB035U					
	2,500	3,000	□180	FFP55D			L7NHB050U		
			□180	FFP75D			L7NHB075U		
			□220	FGP22D			L7NHB020U		
			□220	FGP35D			L7NHB035U		
			□220	FGP55D			L7NHB050U		
			□220	FGP75D			L7NHB075U		
1,500	3,000	□130	FEP05G	L7NHB010U					
		□130	FEP09G	L7NHB010U					
		□130	FEP13G	L7NHB020U					
		□130	FEP17G	L7NHB020U					
		□180	FFP20G	L7NHB020U					
	2,700	3,000	□180	FFP30G	L7NHB035U				
			□180	FFP44G	L7NHB050U				
			□180	FFP60G	L7NHB075U				
			□180	FFP75G	L7NHB075U				
			□220	FGP20G	L7NHB020U				
			□220	FGP30G	L7NHB035U				
			□220	FGP44G	L7NHB050U				
			□220	FGP60G	L7NHB075U				
			□220	FGP85G	L7NHB150U				
2,000	2,000	□220	FGP110G	L7NHB150U					
		□220	FGP150G	L7NHB150U					
		□220	FGP20M	L7NHB020U					
		□220	FGP30M	L7NHB035U					
1,000	2,000	□130	FEP03M	L7NHB010U					
		□130	FEP06M	L7NHB010U					
		□130	FEP09M	L7NHB010U					
		□130	FEP12M	L7NHB020U					
		□180	FFP12M	L7NHB020U					
		□180	FFP20M	L7NHB020U					
	1,700	2,000	□180	FFP30M	L7NHB035U				
			□180	FFP44M	L7NHB050U				
			□220	FGP12M	L7NHB020U				
			□220	FGP20M	L7NHB020U				
			□220	FGP30M	L7NHB035U				
			□220	FGP44M	L7NHB050U				
2,000	2,000	□220	FGP60M	L7NHB150U					
		□220	FGP12M	L7NHB020U					
		□220	FGP20M	L7NHB020U					
		□220	FGP30M	L7NHB035U					

L7CA

Rated Speed (rpm)	Maximum Speed (rpm)	Flange	Motor	Drive	Encoder Cable		Power	Power + Brake	Brake
					Serial	Absolute			
3,000	5,000	□40	FALR5A	L7CA001U	APCS-E □□□ES	APCS-E □□□ES1	APCS- P□□□LSC	-	APCS-B□□□QS
		□40	FAL01A	L7CA001U					
		□40	FAL015A	L7CA002U					
		□60	FBL01A	L7CA001U					
		□60	FBL02A	L7CA002U					
		□60	FBL04A	L7CA004U					
		□80	FCL04A	L7CA004U					
		□80	FCL06A	L7CA008U					
		□80	FCL08A	L7CA008U					
		□80	FCL10A	L7CA010U					
2,000	2,500	□80	FCL03D	L7CA004U	APCS-E □□□ES	APCS-E □□□ES1	APCS- P□□□LSC	-	APCS-B□□□QS
		□80	FCL05D	L7CA008U					
		□80	FCL06D	L7CA008U					
		□80	FCL07D	L7CA008U					



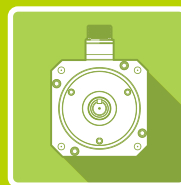

Servo Motor

Contents

E Series	88
F Series	100
Magnetic Encoder Servo Motor	116
MDM-D Series	122
MDM-DF Series	132

Servo Motor Designation



APM - **E** **B** **04** **A** **M3** **K** **2**

Model Name APM : Servo Motor	Flange Size A : Flange Size : 40mm B : Flange Size : 60mm C : Flange Size : 80mm E : Flange Size : 130mm F : Flange Size : 180mm	Rated Rotation Speed A : 3,000 rpm D : 2,000 rpm G : 1,500 rpm M : 1,000 rpm	Shaft Type K: Rounded key on one side (standard) N : Straight
---	--	---	--

Model Type	Motor Capacity		Encoder Type	Option
E : E Series	R5 : 50W	12 : 1.2kW	M3 : 23Bit S-Turn Absolute BiSS-C (16Bit M-Turn Absolute BiSS-C)	None: No options
	01 : 100W	15 : 1.5kW		1 : Oil Seal
	015 : 150W	16 : 1.6kW	L (Battery-less) : 20Bit S-Turn Absolute BiSS-C (16Bit M-Turn Absolute BiSS-C)	2 : Brake
	02 : 200W	20 : 2kW		3 : Oil Seal and Brake
	03 : 300W	22 : 2.2kW		
	04 : 400W	30 : 2.9kW, 3.0kW		
	06 : 600W	44 : 4.4kW		
	08 : 750W	50 : 4.7kW		
	09 : 900W	60 : 6kW		
	10 : 1kW	75 : 7.5kW		
	11 : 1.1kW			

Motor Specifications

Item	Unit	EAR5A			EA01A			EA015A		
Applicable Drive		iX7NHA001U	L7□A001□	L7CA001U	iX7NHA001U	L7□A001□	L7CA001U	iX7NHA002U	L7□A002□	L7CA002U
Flange Size(□)		□40								
Rated Output	[kW]	0.05			0.1			0.15		
Rated Torque	[N·m]	0.16			0.32			0.48		
	[kgf·cm]	1.62			3.25			4.87		
Max. Instantaneous Torque	[N·m]	0.56	0.48		1.11	0.96		1.67	1.43	
	[kgf·cm]	5.68	4.87		11.37	9.74		17.05	14.62	
Rated Current	[A]	1.17			1.10			1.21		
Max. Current	[A]	4.09	3.51		3.85	3.3		4.25	3.64	
Rated Speed	[r/min]	3,000								
Max. Speed	[r/min]	6,500	5,000		6,500	5,000		6,000	5,000	
Inertia Moment	[kg·m ² ×10 ⁻⁴]	0.038			0.071			0.123		
	[gf·cm·s ²]	0.039			0.072			0.125		
Allowable Load Inertia Ratio ^{Note2,3)}		Motor Inertia × 30								
Rated Power Rate	[kW/s]	6.68			14.31			18.61		
Speed/Position Detector	Standard	Serial Multi-Turn Absolute Built-in Type (23Bit)								
	Option	Batteryless : Serial Multi-Turn Absolute Built-in Type(20Bit) ^{Note 6)}								
Specifications & Features	Protection	Fully closed, self cooling IP67 ^{Note 1)}								
	Rated Time	Continuous								
	Ambient Temp	Operating: 0 ~ 40[°C] Storage : -10 ~ 60[°C]								
	Ambient Humidity	Operating: Below 80[%]RH / Storage: Below 90[%]RH (noncondensing)								
	Atmosphere	Avoid direct sunlight and corrosive / flammable gas or liquid.								
	Vibration Resistance	Vibration acceleration 49[m/s ²](5G)								
Weight	[kg]	0.26(0.44)			0.37(0.55)			0.55		

Note1) Axis penetration not included. The IP rating for attached reducers is not guaranteed. Product may not qualify marked IP rating if reducers are attached or cables are bent beyond designated specifications. Use our standard cables for IP rating qualification.

Note2) Load inertia ratio should be reduced for faster response.

Note3) The allowable load inertia ratio applies when servo motor is operated at a constant speed.

Note4) EA Series products should be connected to power first, and then connected to the encoder.

Note5) Please inquire for EA015A products.

Note6) Batteryless encoders should not be operated near strong magnetic fields.

Speed-Torque Characteristics

- 3-Phase AC200V
- 3-Phase AC230V (L7C 1-Phase)

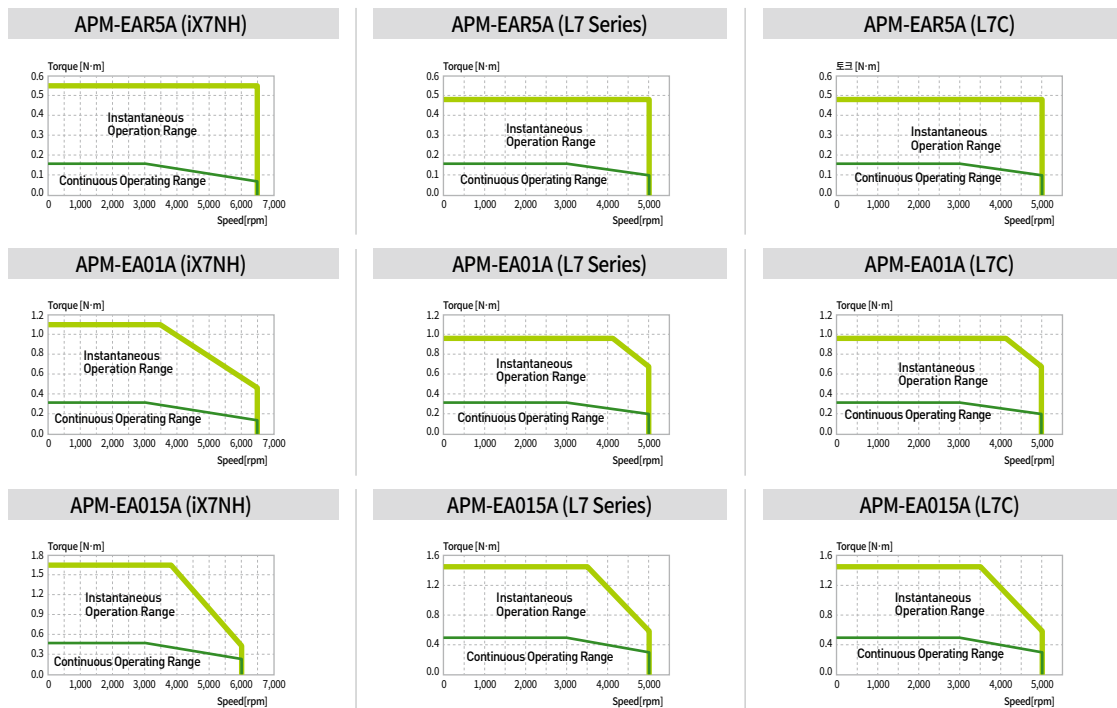

※ □40 Products have same operation range regardless of input voltage (200/230V)

Motor Specifications

Item	Unit	EB01A			EB02A			EB04A		
Applicable Drive		ix7NHA001U	L7□A001□	L7CA001U	ix7NHA002U	L7□A002□	L7CA002U	ix7NHA004U	L7□A004□	L7CA004U
Flange Size(□)		□60								
Rated Output	[kW]	0.1			0.2			0.4		
	[N·m]	0.32			0.64			1.27		
Rated Torque	[kgf·cm]	3.25			6.50			12.99		
	[N·m]	1.11	0.96	2.23	1.91	4.46	3.82			
Max. Instantaneous Torque	[kgf·cm]	11.37	9.74	22.74	19.49	45.47	38.98			
	[A]	1.15			1.37			2.65		
Max. Current	[A]	4.01	3.44	4.78	4.10	9.27	7.95			
Rated Speed	[r/min]	3,000								
Max. Speed	[r/min]	6,500	5,000	6,500	5,000	6,500	5,000			
Inertia Moment	[kg·m ² ×10 ⁻⁴]	0.172			0.309			0.584		
	[gf·cm·s ²]	0.176			0.315			0.596		
Allowable Load Inertia Ratio	Note2, 3)	Motor Inertia × 20						Motor Inertia × 15		
Rated Power Rate	[kW/s]	5.89			13.10			27.78		
Speed/Position Detector	Standard	Serial Multi-Turn Absolute Built-in Type (23Bit)								
	Option	Batteryless : Serial Multi-Turn Absolute Built-in Type(20Bit) ^{Note 4)}								
Specifications & Features	Protection	Fully closed, self cooling IP67 ^{Note 1)}								
	Rated Time	Continuous								
	Ambient Temp	Operating: 0 ~ 40[°C] Storage : -10 ~ 60[°C]								
	Ambient Humidity	Operating: Below 80[%]RH / Storage: Below 90[%]RH (noncondensing)								
	Atmosphere	Avoid direct sunlight and corrosive / flammable gas or liquid.								
	Vibration Resistance	Vibration acceleration 49[m/s ²](5G)								
Weight	[kg]	0.59(0.95)			0.76(1.12)			1.10(1.46)		

Note1) Axis penetration not included. The IP rating for attached reducers is not guaranteed. Product may not qualify marked IP rating if reducers are attached or cables are bent beyond designated specifications. Use our standard cables for IP rating qualification.

Note2) Load inertia ratio should be reduced for faster response.

Note3) The allowable load inertia ratio applies when servo motor is operated at a constant speed.

Note4) Batteryless encoders should not be operated near strong magnetic fields.

Speed-Torque Characteristics

■ 3-Phase AC200V

■ 3-Phase AC230V

(L7C 1-Phase)

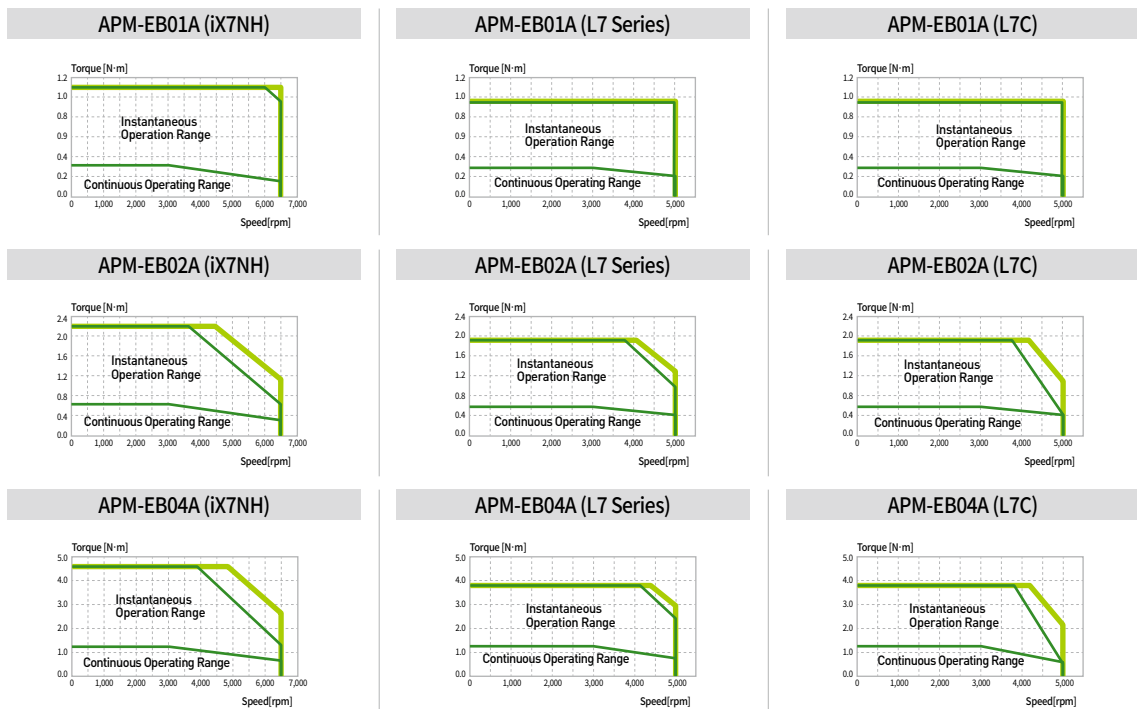

Motor Specifications

Item	Unit	EC04A			EC06A			EC08A			EC10A		
Applicable Drive		ix7NHA004U	L7□A004□	L7CA004U	ix7NHA008U	L7□A008□	L7CA008U	ix7NHA008U	L7□A008□	L7CA008U	ix7NHA010U	L7□A010□	L7CA010U
Flange Size(□)		□80											
Rated Output	[kW]	0.4			0.6			0.75			1		
Rated Torque	[N·m]	1.27			1.91			2.39			3.18		
	[kgf·cm]	12.99			19.49			24.36			32.48		
Max. Instantaneous Torque	[N·m]	4.46	3.82	6.68	5.73	8.36	7.16	9.55					
	[kgf·cm]	45.47	38.98	68.21	58.47	85.26	73.08	97.44					
Rated Current	[A]	2.52			4.29			4.63			5.30		
Max. Current	[A]	8.82	7.56	15.01	12.87	16.21	13.90	15.91					
Rated Speed	[r/min]	3,000											
Max. Speed	[r/min]	6,000	5,000	6,000	5,000	6,000	5,000	5,500	5,000	4,500			
Inertia Moment	[kg·m ² ×10 ⁻⁴]	0.861			1.410			1.567			2.352		
	[gf·cm·s ²]	0.879			1.439			1.599			2.400		
Allowable Load Inertia Ratio ^{Note2,3)}		Motor Inertia × 15						Motor Inertia × 10					
Rated Power Rate	[kW/s]	18.82			25.86			36.36			43.08		
Speed/Position Detector	Standard	Serial Multi-Turn Absolute Built-in Type(23Bit)											
	Option	Batteryless : Serial Multi-Turn Absolute Built-in Type(20Bit) ^{Note 4)}											
Specifications & Features	Protection	Fully closed, self cooling IP67 ^{Note 1)}											
	Rated Time	Continuous											
	Ambient Temp	Operating: 0 ~ 40[°C] Storage : -10 ~ 60[°C]											
	Ambient Humidity	Operating: Below 80[%]RH / Storage: Below 90[%]RH (noncondensing)											
	Atmosphere	Avoid direct sunlight and corrosive / flammable gas or liquid.											
	Vibration Resistance	Vibration acceleration 49[m/s ²](5G)											
Weight	[kg]	1.41(2.08)			1.86(2.53)			2.00(2.67)			2.69(3.36)		

^{Note1)} Axis penetration not included. The IP rating for attached reducers is not guaranteed. Product may not qualify marked IP rating if reducers are attached or cables are bent beyond designated specifications. Use our standard cables for IP rating qualification.

^{Note2)} Load inertia ratio should be reduced for faster response.

^{Note3)} The allowable load inertia ratio applies when servo motor is operated at a constant speed.

^{Note4)} Batteryless encoders should not be operated near strong magnetic fields.

Speed-Torque Characteristics

- 3-Phase AC200V
 - 3-Phase AC230V
- (L7C 1-Phase)



Motor Specifications

Item	Unit	EE09A		EE15A		EE22A		EE30A		EF30A	EF50A
Applicable Drive		ix7NHA010	L7□A010	ix7NHA020	L7□A020	ix7NHA020	L7□A020	ix7NHA035	L7□A035	L7□A035	L7□A050
Flange Size(□)		□130								□180	
Rated Output	[kW]	0.9		1.5		2.2		3		3	4.7
	[N·m]	2.86		4.77		7		9.55		9.55	14.96
Rated Torque	[kgf·cm]	29.2		48.7		71.4		97.4		97.44	152.66
	[N·m]	8.59		14.32		21.01		28.65		28.65	44.88
Max. Instantaneous Torque	[kgf·cm]	87.7		146.1		214.3		292.2		292.33	457.98
	[A]	6.17		10.96		12.08		14.29		15.31	24.6
Max. Current	[A]	18.51		32.88		36.24		42.87		45.93	73.8
Rated Speed	[r/min]	3,000									
Max. Speed	[r/min]	6,000	5,000	6,000	5,000	6,000	5,000	5,500	4,300	5,000	5,000
Inertia Moment	[kg·m ² ×10 ⁻⁴]	4.55		8.4		12.28		16.15		28.44	39.82
	[gf·cm·s ²]	4.643		8.571		12.531		16.48		29.02	40.633
Allowable Load Inertia Ratio	Note2, 3)	Motor Inertia × 10								Motor Inertia × 5	
Rated Power Rate	[kW/s]	18.04		27.14		39.93		56.46		32.06	56.21
Speed/Position Detector	Standard	Serial Multi-Turn Absolute Built-in Type (23Bit)									
	Option	Batteryless : Serial Multi-Turn Absolute Built-in Type(20Bit) ^{Note 4)}									
Specifications & Features	Protection	Fully closed, self cooling IP65 ^{Note 1)}									
	Rated Time	Continuous									
	Ambient Temp	Operating: 0 ~ 40[°C] Storage : -10 ~ 60[°C]									
	Ambient Humidity	Operating: Below 80[%]RH / Storage: Below 90[%]RH (noncondensing)									
	Atmosphere	Avoid direct sunlight and corrosive / flammable gas or liquid.									
	Vibration Resistance	Vibration acceleration 49[m/s ²](5G)									
Weight	[kg]	4.7		6.2		7.8		9.4		12.1	15.1

Note1) Axis penetration not included. The IP rating for attached reducers is not guaranteed. Product may not qualify marked IP rating if reducers are attached or cables are bent beyond designated specifications. Use our standard cables for IP rating qualification.

Note2) Load inertia ratio should be reduced for faster response.

Note3) The allowable load inertia ratio applies when servo motor is operated at a constant speed.

Note4) Batteryless encoders should not be operated near strong magnetic fields.

Speed-Torque Characteristics

- 3-Phase AC200V
- 3-Phase AC230V

(L7C 1-Phase)

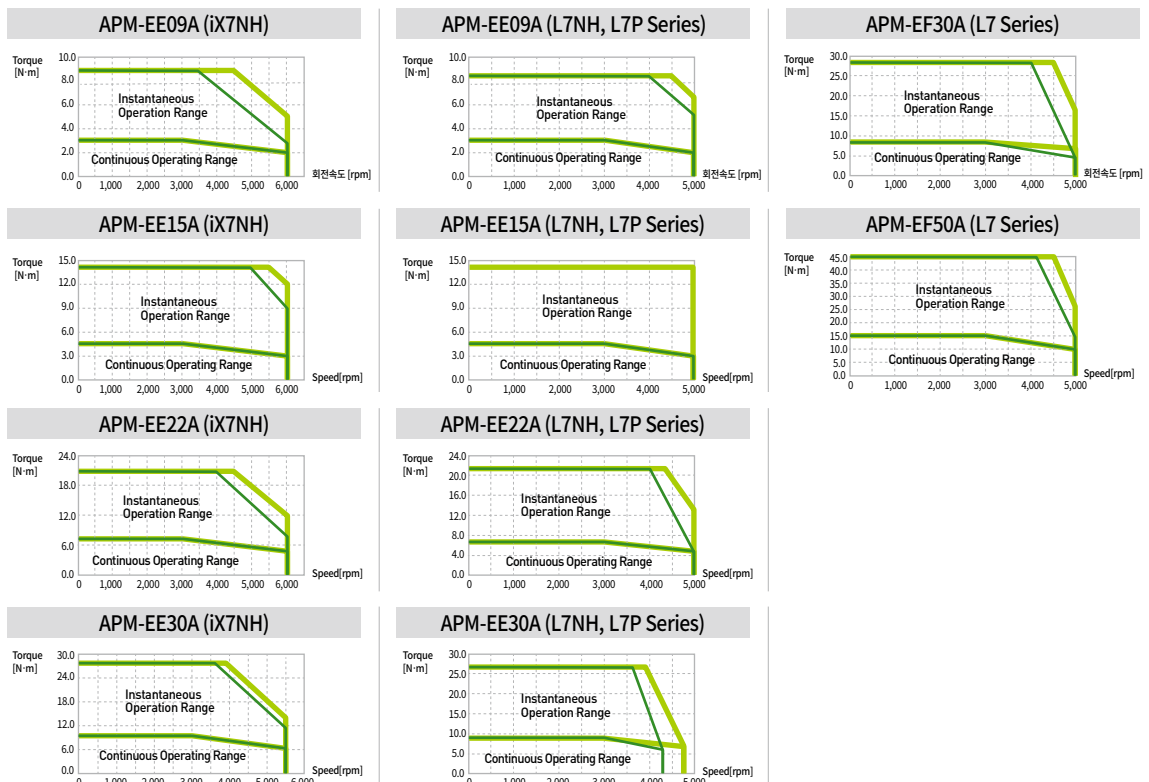

Motor Specifications

Item	Unit	EE06D	EE11D	EE16D	EE22D	EF20G	EF30G	EF44G	EF60G	EF75G
Applicable Drive		L7□A008	L7□A010	L7□A020		L7□A020	L7□A035	L7□A050	L7□A075	L7□A075
Flange Size(□)		□130				□180				
Rated Output	[kW]	0.6	1.1	1.6	2.2	1.8	2.9	4.4	6	7.5
Rated Torque	[N·m]	2.86	5.25	7.64	10.5	11.46	18.46	28.01	38.2	47.75
	[kgf·cm]	29.23	53.59	77.95	107.19	116.93	188.39	285.83	389.77	487.21
Max. Instantaneous Torque	[N·m]	8.59	15.76	22.92	31.51	34.38	55.39	84.03	95.49	143.24
	[kgf·cm]	87.7	160.78	233.86	321.56	350.79	565.16	857.49	974.42	1461.63
Rated Current	[A]	4.29	5.73	8.86	10.94	11.21	15.05	28.66	34	30.45
Max. Current	[A]	12.87	17.19	26.58	32.82	33.63	45.15	85.98	85	91.35
Rated Speed	[r/min]	2,000				1,500				
Max. Speed	[r/min]	3,000	3,000	3,000	3,000	3,000	2,500	3,000	2,500	2,000
Inertia Moment	[kg·m ² ×10 ⁻⁴]	4.55	8.4	12.28	16.15	28.44	39.82	63.37	91.99	106.65
	[gf·cm·s ²]	4.643	8.571	12.531	16.48	29.02	40.633	64.663	93.867	108.827
Allowable Load Inertia Ratio ^{Note2,3)}		Motor Inertia × 10				Motor Inertia × 5				
Rated Power Rate	[kW/s]	18.04	32.84	47.53	68.32	46.17	85.6	123.82	158.61	213.76
Speed/Position Detector	Standard	Serial Multi-Turn Absolute Built-in Type (23Bit)								
	Option	Batteryless : Serial Multi-Turn Absolute Built-in Type(20Bit) ^{Note 4)}								
Specifications & Features	Protection	Fully closed, self cooling IP65 ^{Note 1)}								
	Rated Time	Continuous								
	Ambient Temp	Operating: 0 ~ 40[°C] Storage : -10 ~ 60[°C]								
	Ambient Humidity	Operating: Below 80[%]RH / Storage: Below 90[%]RH (noncondensing)								
	Atmosphere	Avoid direct sunlight and corrosive / flammable gas or liquid.								
	Vibration Resistance	Vibration acceleration 49[m/s ²](5G)								
Weight	[kg]	4.7	6.2	7.8	9.4	12.1	15.1	20.8	27.7	32

^{Note1)} Axis penetration not included. The IP rating for attached reducers is not guaranteed. Product may not qualify marked IP rating if reducers are attached or cables are bent beyond designated specifications. Use our standard cables for IP rating qualification.

^{Note2)} Load inertia ratio should be reduced for faster response.

^{Note3)} The allowable load inertia ratio applies when servo motor is operated at a constant speed.

^{Note4)} Batteryless encoders should not be operated near strong magnetic fields.

Speed-Torque Characteristics

- 3-Phase AC200V
 - 3-Phase AC230V
- (LTC 1-Phase)

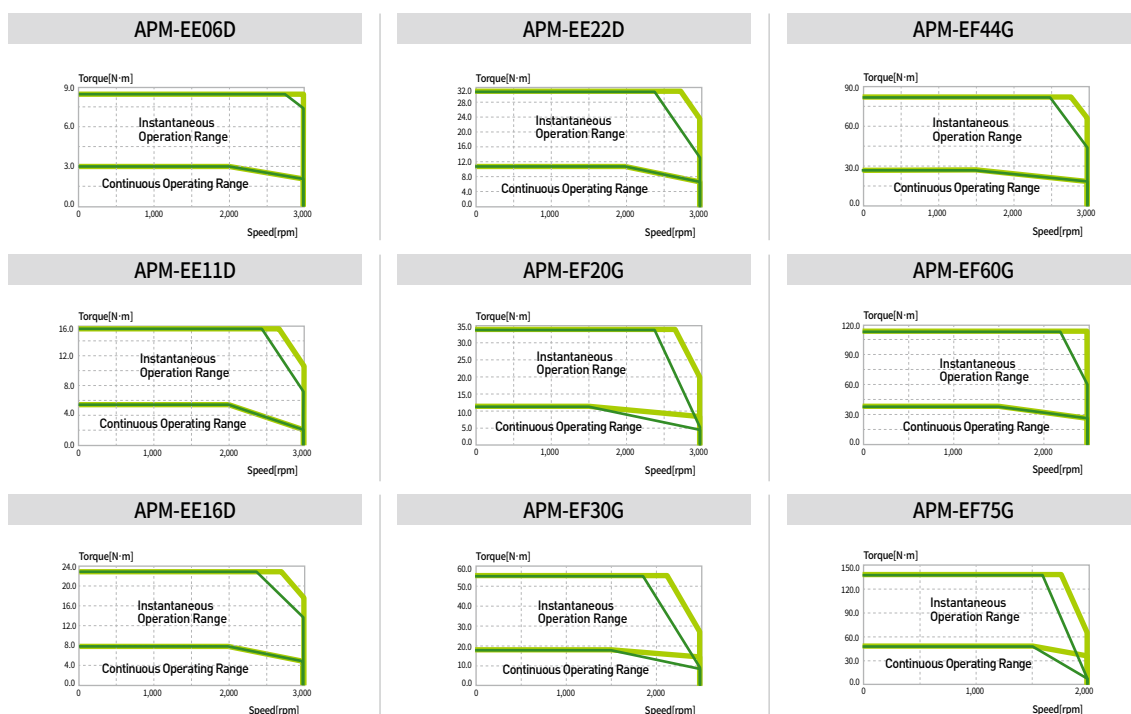

Servo Motor

Motor Specifications

항목	단위	EE03M	EE06M	EE09M	EE12M	EF12M	EF20M	EF30M	EF44M
Applicable Drive		L7□A004	L7□A008	L7□A010		L7□A020		L7□A035	L7□A050
Flange Size(□)		□130				□180			
Rated Output	[kW]	0.3	0.6	0.9	1.2	1.2	2	3	4.4
	[N·m]	2.86	5.73	8.59	11.46	11.46	19.1	28.65	42.02
Rated Torque	[kgf·cm]	29.23	58.47	87.7	116.93	116.93	194.88	292.33	428.74
	[N·m]	8.59	17.19	25.78	34.38	34.38	57.3	85.94	126.05
Max. Instantaneous Torque	[kgf·cm]	87.7	175.4	263.09	350.79	350.79	584.65	876.98	1286.23
	[A]	2.71	4.22	5.73	10.07	11.24	13.46	15.53	29.77
Max. Current	[A]	8.13	12.66	17.19	30.21	33.72	40.38	46.59	89.31
Rated Speed	[r/min]	1,000							
Max. Speed	[r/min]	2,000	2,000	2,000	2,000	2,000	2,000	1,500	2,000
Inertia Moment	[kg·m ² ×10 ⁻⁴]	4.55	8.4	12.28	16.15	28.44	39.82	63.37	91.99
	[gf·cm·s ²]	4.643	8.571	12.531	16.48	29.02	40.633	64.663	93.867
Allowable Load Inertia Ratio ^{Note2, 3)}		Motor Inertia × 10				Motor Inertia × 5			
Rated Power Rate	[kW/s]	18.04	39.08	60.15	81.31	46.17	91.6	129.51	191.91
Speed/Position Detector	Standard	Serial Multi-Turn Absolute Built-in Type (23Bit)							
	Option	Batteryless : Serial Multi-Turn Absolute Built-in Type(20Bit) ^{Note 4)}							
Specifications & Features	Protection	Fully closed, self cooling IP65 ^{Note 1)}							
	Rated Time	Continuous							
	Ambient Temp	Operating: 0 ~ 40[°C] Storage : -10 ~ 60[°C]							
	Ambient Humidity	Operating: Below 80[%]RH / Storage: Below 90[%]RH (noncondensing)							
	Atmosphere	Avoid direct sunlight and corrosive / flammable gas or liquid.							
	Vibration Resistance	Vibration acceleration 49[m/s ²](5G)							
Weight	[kg]	4.7	6.2	7.8	9.4	12.1	15.1	20.8	27.7

Note1) Axis penetration not included. The IP rating for attached reducers is not guaranteed. Product may not qualify marked IP rating if reducers are attached or cables are bent beyond designated specifications. Use our standard cables for IP rating qualification.

Note2) Load inertia ratio should be reduced for faster response.

Note3) The allowable load inertia ratio applies when servo motor is operated at a constant speed.

Note4) Batteryless encoders should not be operated near strong magnetic fields.

Speed-Torque Characteristics

- 3-Phase AC200V
 - 3-Phase AC230V
- (L7C 1-Phase)

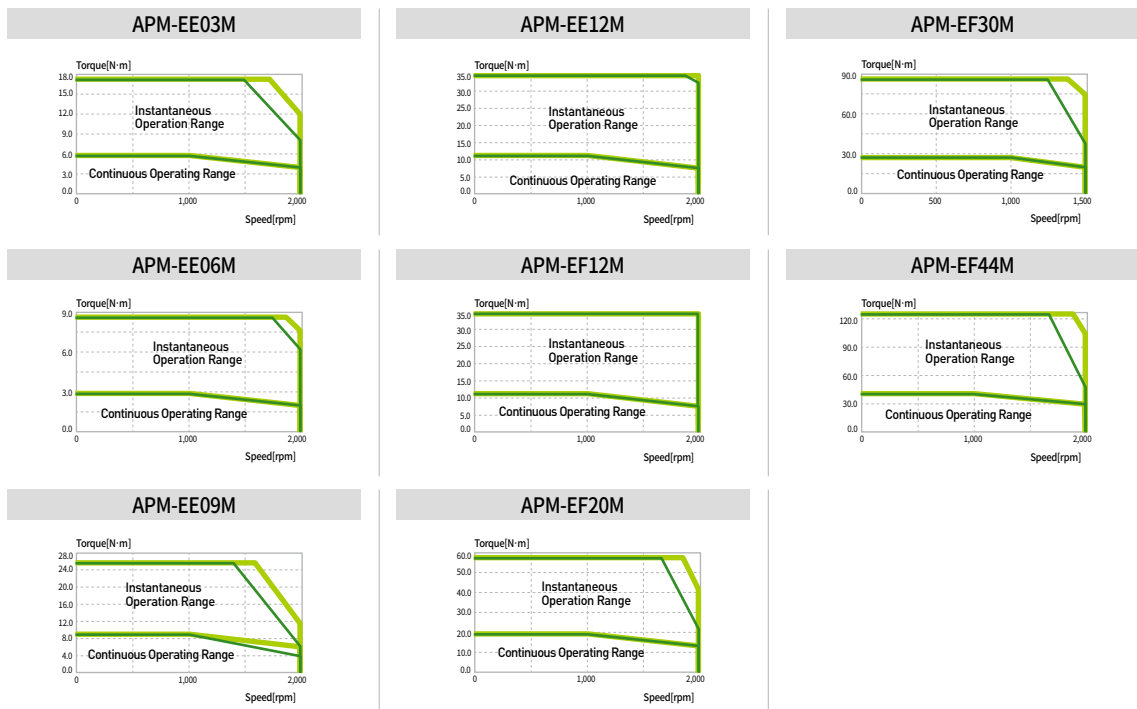

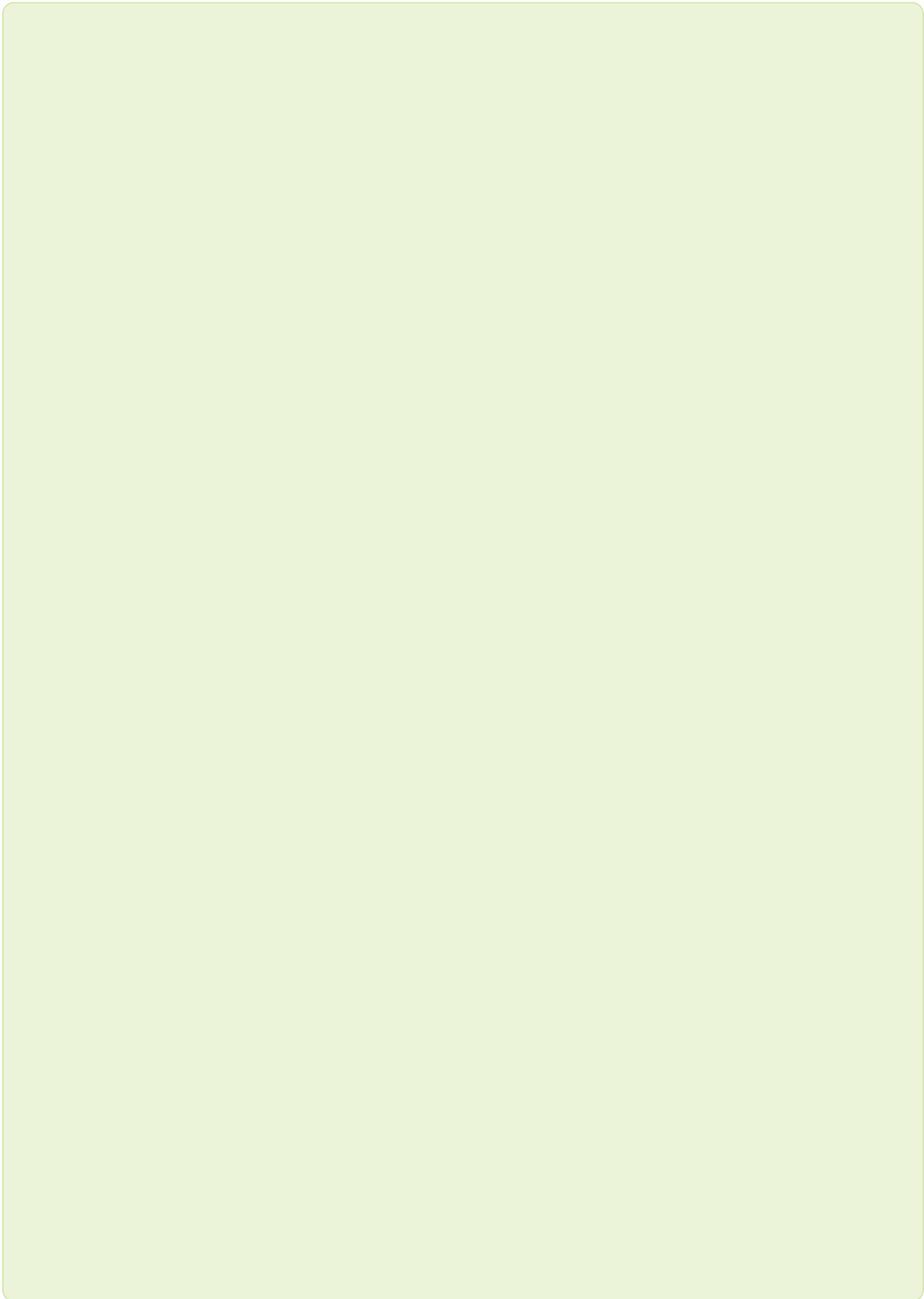

EA Series

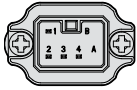

SC-MC6P-AK2G-05

Plug Specifications

Power (Non Brake)

Pin No.	Signal
1	FG
2	U
3	V
4	W

(Power Connector Pin Table)

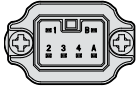

SC-MC6P-AK2G-04

Power (Brake)

Pin No.	Signal
1	FG
2	U
3	V
4	W
A	BK+
B	BK-

(Power Connector Pin Table)

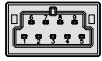

RECEPTACLE:
JN13CD09PN1
PIN:
JN-24S-C1B-B1-10000

Encoder

Pin No.	Signal
1	SHIELD
2	SLO
3	SLO
4	MA
5	MA
6	GND_B
7	VDD_B
8	OV
9	+5V

(Encoder Connector Pin Table)

Note) Avoid excessive shock to motor when connecting keys; the shock may damage encoders or bearings.

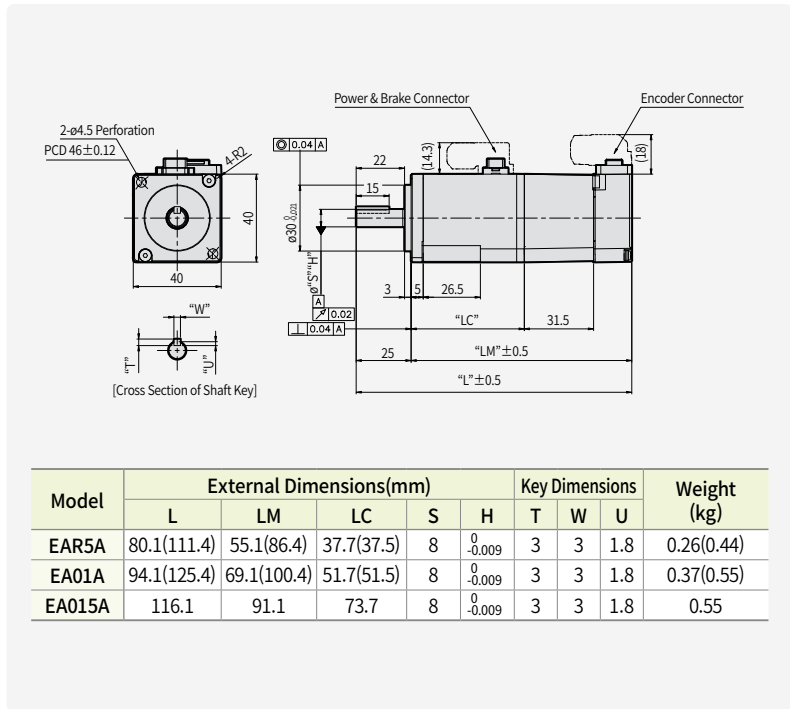

Note) () Dimensions in parantheses are for servo motors with integrated maintenance brakes.

EA Series (Batteryless)

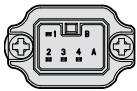

GAMC3095

Plug Specifications

Power (Non Brake)

Pin No.	Signal
1	FG
2	U
3	V
4	W

(Power Connector Pin Table)

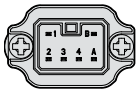

GAMC3079

Power (Brake)

Pin No.	Signal
1	FG
2	U
3	V
4	W
A	BK+
B	BK-

(Power Connector Pin Table)

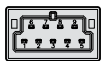

RECEPTACLE:
JN13CD09PN1
PIN:
JN-24S-C1B-B1-10000

Encoder

Pin No.	Signal
1	SHIELD
2	SLO
3	SLO
4	MA
5	MA
6	-
7	-
8	OV
9	+5V

(Encoder Connector Pin Table)

Note) Avoid excessive shock to motor when connecting keys; the shock may damage encoders or bearings.

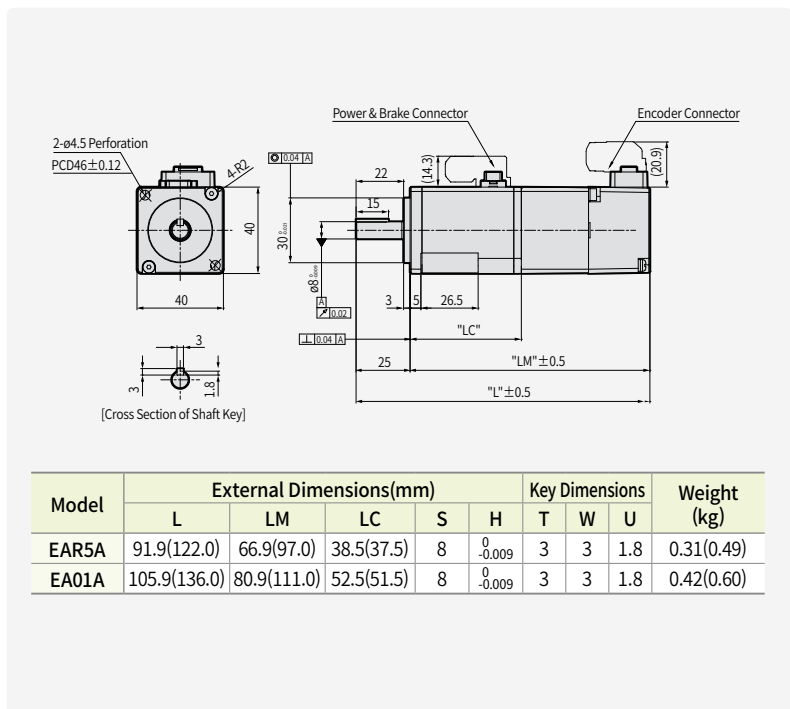

Note) () Dimensions in parantheses are for servo motors with integrated maintenance brakes. Batteryless encoders should not be operated near strong magnetic fields.

EB Series

Plug Specifications



SC-MC6P-AJ2G-05

Power (Non Brake)

Pin No.	Signal
1	U
2	V
3	W
4	FG

(Power Connector Pin Table)



SC-MC6P-AJ2G-04

Power (Brake)

Pin No.	Signal
1	U
2	V
3	W
4	FG
A	BK+
B	BK-

(Power Connector Pin Table)

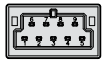

RECEPTACLE :
JN13CD09PN1
PIN :
JN-24S-C1B-B1-10000

Encoder

Pin No.	Signal
1	SHIELD
2	SLO
3	SLO
4	MA
5	MA
6	GND_B
7	VDD_B
8	OV
9	+5V

(Encoder Connector Pin Table)

Note) Avoid excessive shock to motor when connecting keys; the shock may damage encoders or bearings.
Batteryless encoders have no signals for pins 6 and 7.

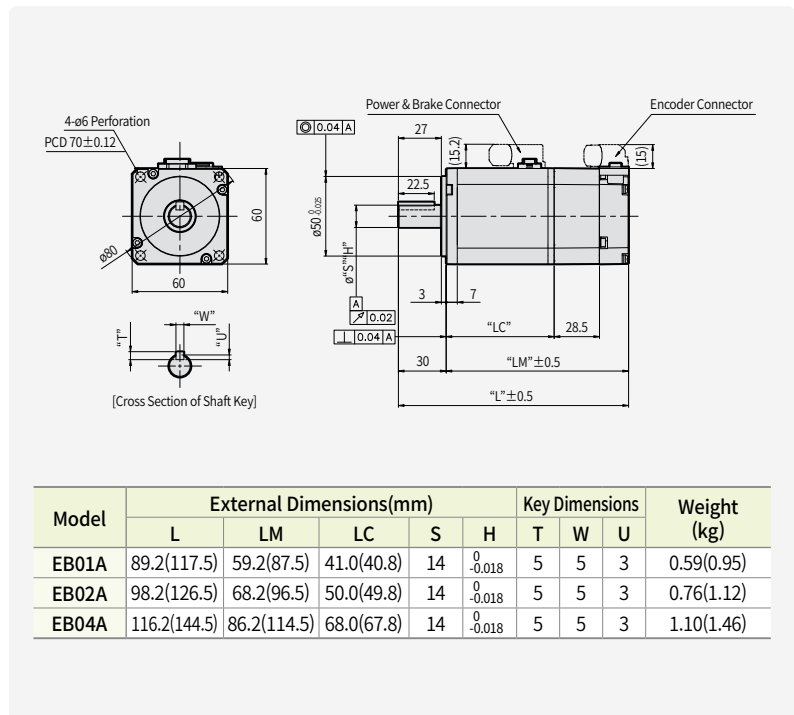

Note) () Dimensions in parantheses are for servo motors with integrated maintenance brakes.
For non-brake models with batteryless encoders, the dimensions L and LM increase by 11.8[mm].
For brake models with batteryless encoders, the dimensions L and LM increase by 12.0[mm].
For all models with batteryless encoders, the weight increases by 0.06[kg].
Batteryless encoders should not be operated near strong magnetic fields.

EC Series

Plug Specifications

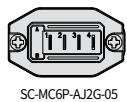

SC-MC6P-AJ2G-05

Power (Non Brake)

Pin No.	Signal
1	U
2	V
3	W
4	FG

(Power Connector Pin Table)

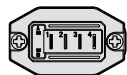

SC-MC6P-AJ2G-04

Power (Brake)

Pin No.	Signal
1	U
2	V
3	W
4	FG
A	BK+
B	BK-

(Power Connector Pin Table)

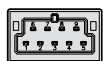

RECEPTACLE :
JN13CD09PN1
PIN :
JN-24S-C1B-B1-10000

Encoder

Pin No.	Signal
1	SHIELD
2	SLO
3	SLO
4	MA
5	MA
6	GND_B
7	VDD_B
8	OV
9	+5V

(Encoder Connector Pin Table)

Note) Avoid excessive shock to motor when connecting keys; the shock may damage encoders or bearings.
Batteryless encoders have no signals for pins 6 and 7.

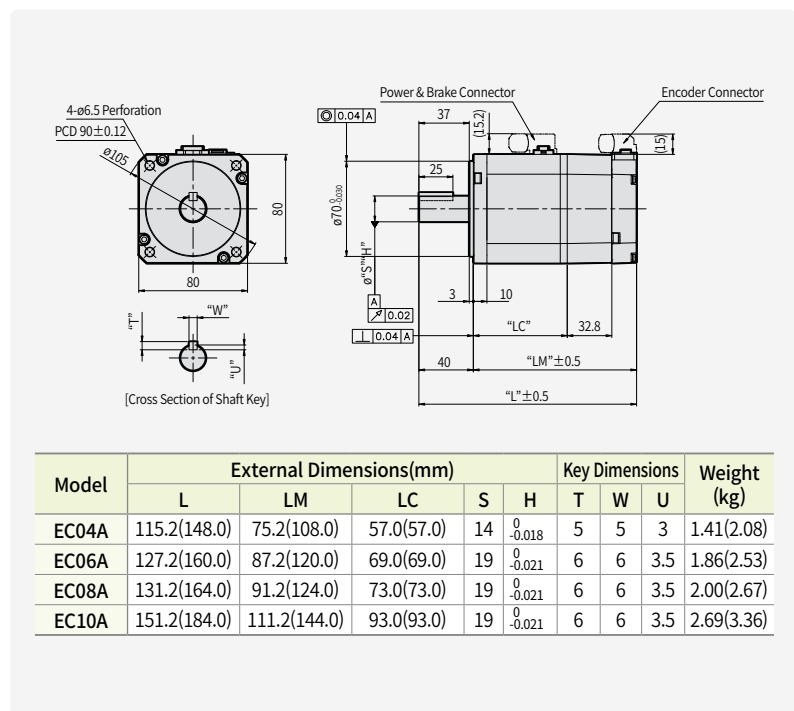

Note) () Dimensions in parantheses are for servo motors with integrated maintenance brakes.
For non-brake models with batteryless encoders, the dimensions L and LM increase by 11.8[mm].
For brake models with batteryless encoders, the dimensions L and LM increase by 12.0[mm].
For all models with batteryless encoders, the weight increases by 0.06[kg].
Batteryless encoders should not be operated near strong magnetic fields.

EE Series

Plug Specifications



Specifications:
MS3102A20-4P(Standard)



Specifications:
MS3102A20-15P
(Brake-attached type)



SC-CMV1-R10PTG-4

Power (Non Brake)

Pin No.	Signal
A	U
B	V
C	W
D	접지선

Pin No.	Signal	Pin No.	Signal
A	U	D	Ground
B	V	E	BK+
C	W	F	BK-

Encoder

Pin No.	Signal
1	+5V
2	OV
3	-
4	VDD_B
5	GND_B
6	MA
7	MA
8	SLO
9	SLO
10	SHIELD

(Multi Turn Encoder Connector Pin Table)

Note Avoid excessive shock to motor when connecting keys; the shock may damage encoders or bearings.
Batteryless encoders have no signals for pins 6 and 7.

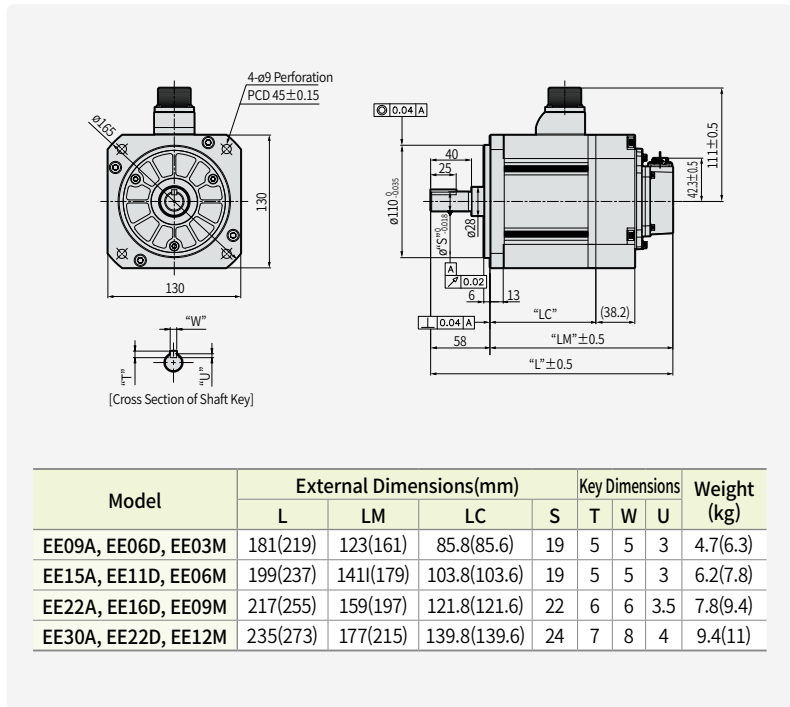

Note For both non-brake and brake models with batteryless encoders, the dimensions L and LM increase by 11.2[mm].
Note For all models with batteryless encoders, the weight increases by 0.06[kg].
Note Batteryless encoders should not be operated near strong magnetic fields.

EF Series

Plug Specifications



Specifications:
MS3102A22-22P(Standard)



Specifications:
MS3102A24-10P
(Brake-attached type)



SC-CMV1-R10PTG-4

Power (Non Brake)

Pin No.	Signal
A	U
B	V
C	W
D	Grounding Wire

Pin No.	Signal	Pin No.	Signal
A	U	D	Ground
B	V	E	BK+
C	W	F	BK-

Encoder

Pin No.	Signal
1	+5V
2	OV
3	-
4	VDD_B
5	GND_B
6	MA
7	MA
8	SLO
9	SLO
10	SHIELD

(Multi Turn Encoder Connector Pin Table)

Note Avoid excessive shock to motor when connecting keys; the shock may damage encoders or bearings.
Batteryless encoders have no signals for pins 6 and 7.

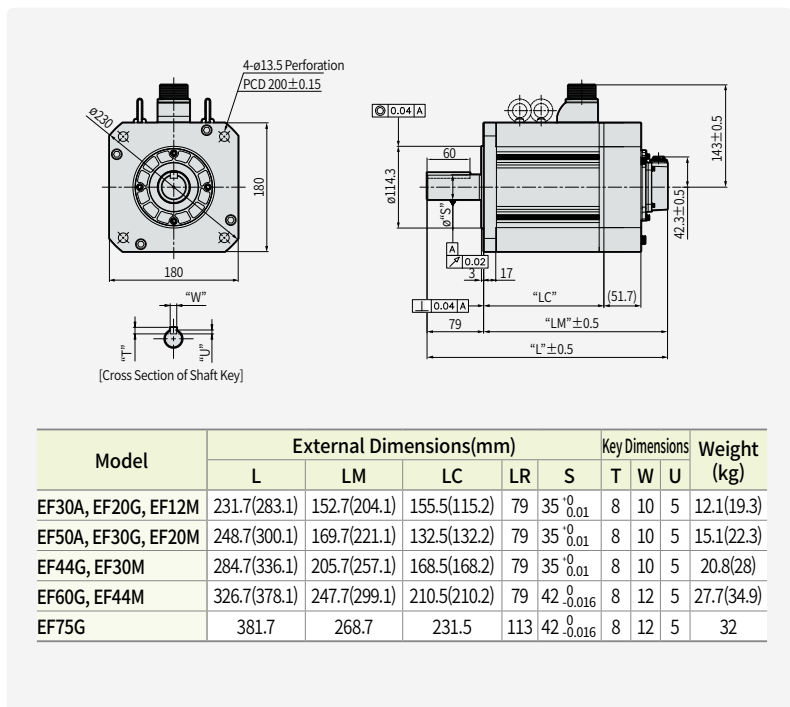

Note For both non-brake and brake models with batteryless encoders, the dimensions L and LM increase by 11.2[mm].
Note For all models with batteryless encoders, the weight increases by 0.06[kg].
Note Batteryless encoders should not be operated near strong magnetic fields.

Brake Specifications

Motor Series	EA	EB	EC	EF	FF
Use	Maintenance	Maintenance	Maintenance	Maintenance	Maintenance
Input Voltage [V]	DC 24V	DC 24V	DC 24V	DC 24V	DC 24V
Static Friction Torque [N•m]	0.32	1.47	3.23	10.4	40
Capacity [W]	4.5	6.6	7.3	19.4	25
Rated Current [A]	0.17	0.27	0.3	29.6	23
Braking System	Spring brake	Spring brake	Spring brake	0.81	1.04
Insulation Level	F	F	F	F	F

Note) 1. Electronic brakes should only be used to maintain static state, and never to stop moving motors.
 2. The specifications of electronic brakes are measured at 20°C.
 3. These specifications are subject to change. Please check the voltage specifications on your motors.

Heat Sink Specifications

Classification	Standard(mm) Servo Motor	Material
EA Series (□40)	250×250×6	Aluminum
EB Series (□60)	250×250×6	
EC Series (□80)	250×250×12	
EE Series (□130)	350×350×20	
EF Series (□180)	550×550×30	
EF Series (5kW or more) (□180)	650×650×36	

※ The dimensions above are measured with attached heat sinks.

Servo Motor Designation



APM(C)	F	BL	P	04	A	M	K	1
Model Name APM : Servo motor (Made in Korea) APMC : Servo motor (Made in China)	Flange Size AL : 40 Flange BL : 60 Flange CL : 80 Flange E : 130 Flange F : 180 Flange G : 220 Flange	Motor Capacity R5 : 50[W] 01 : 100[W] 015 : 150[W] 02 : 200[W] 03 : 300[W] 04 : 400[W] 07 : 650[W] 08 : 750[W] 10 : 1.0[kW] 20 : 2.0[kW] 35 : 3.5[kW] 50 : 5.0[kW] 75 : 7.5[kW] 110 : 11[kW] 150 : 15[kW]	Encoder Type M : 19bit S-tum abs (16bit M-turn abs) M8 : 18bit S-tum abs [FAL type] (16bit M-turn abs) Y : 17bit S-turn abs (Magnetic)	Oil Seal, Brake Type None : None 1 : Oil seal attached 2 : Brake attached 3 : Oil seal, Brake attached Note1) In case of 40, 60, 80 flange product, you can apply 200V drive only. Note2) If you apply nonstandard encoder, please contact our office. Note3) Refer to brake operating voltage				
Model Shaft F : Flat shaft	Input Power Supply None : 200VAC P : 400VAC	Rated Speed A : 3000[rpm] D : 2000[rpm] G : 1500[rpm] M : 1000[rpm]	Shape of Shaft End N : Straight K : One side round key (Standard)					

Servo Motor Specifications & Torque Characteristics (200V)

Motor Specifications [Rated 3000r/min]

Servo Motor (APMC-□□□□□)	FALR5A	FAL01A	FAL015A	FBL01A	FBL02A	FBL04A	FCL04A	FCL06A	FCL08A	FCL10A	FCL03D	FCL05D	FCL06D	FCL07D
Applicable Drive	L7□A001	L7□A002	L7□A001	L7□A002	L7□A004	L7□A008	L7□A010	L7□A004	L7□A008	L7□A010	L7□A004	L7□A008	L7□A010	L7□A008
Flange Size(□)	□40				□60				□80					
Rated Output [kW]	0.05	0.1	0.15	0.1	0.2	0.4	0.4	0.6	0.75	1	0.3	0.45	0.55	0.65
Rated Torque [N·m]	0.16	0.32	0.48	0.32	0.64	1.27	1.27	1.91	2.39	3.18	1.43	2.15	2.63	3.1
[kgf·cm]	1.62	3.25	4.87	3.25	6.49	12.99	12.99	19.49	24.36	32.48	14.62	21.92	26.8	31.67
Max. Instantaneous Torque [N·m]	0.48	0.96	1.43	0.96	1.91	3.82	3.82	5.73	7.16	9.55	4.3	6.45	7.88	9.31
[kgf·cm]	4.87	9.74	14.62	9.74	19.48	38.96	38.98	58.47	73.08	97.44	43.85	65.77	80.39	95.01
Rated Current [A]	0.95	1.25	1.60	0.95	1.45	2.6	2.58	3.81	5.02	5.83	2.5	3.05	3.06	3.83
Max. Current [A]	2.85	3.75	4.80	2.85	4.35	7.8	7.75	11.42	15.07	17.5	7.51	9.16	9.18	11.5
Rated Speed [r/min]	3000										2000			
Max. Speed [r/min]	5000										3000			
Inertia Moment [kg·m ² ×10 ⁻⁴]	0.023	0.042	0.063	0.091	0.147	0.248	0.53	0.897	1.264	1.632	0.53	0.897	1.264	1.63
[gf·cm ²]	0.024	0.043	0.065	0.093	0.15	0.253	0.541	0.915	1.29	1.665	0.541	0.915	1.29	1.66
Allowable Load Inertia Ratio	30 times of motor inertia			20 times of motor inertia			15 times of motor inertia							
Rated Power Rate [kW/s]	10.55	23.78	36.19	11.09	27.6	27.07	30.6	40.66	45.09	62.08	38.73	51.47	54.56	59.03
Speed/Position Detector	Standard	Serial Multi-Turn Built-in Type(18bit)					Serial Multi-Turn Built-in Type(19bit)							
Option	×													
Protection	Fully closed-Self cooling IP67 ^{Note1)}													
Rated Time	Continuous													
Ambient Temp	Operating : 0 ~ 40[°C] Storage : -10 ~ 60[°C]													
Ambient Humidity	Operating : Below 80[%]RH / Storage : Below 90[%]RH(Noncondensing)													
Atmosphere	Avoid direct sunlight and corrosive / flammable gas or liquid.													
Vibration Resistance	Vibration acceleration 49[m/s ²](5G)													
Weight [kg]	0.31	0.45	0.61	0.56	0.74	1.06	1.52	2.14	2.68	3.3	1.26	2.12	2.66	2.78

Note1) Axis penetration not included. The IP rating for attached reducers is not guaranteed. Cables may not qualify marked IP rating if bent beyond designated specifications. Use specific cables for IP rating qualification.

Speed-Torque Characteristics

- 3 Phase AC200V
- 3Phase AC230V



Servo Motor

Motor Specifications [Rated 3000r/min]

Servo Motor (APM-□□□□)	FE09A	FE15A	FE22A	FE30A	FF30A	FF50A	
Applicable Drive	L7□A010	L7□A020		L7□A035		L7□A050	
Flange Size(□)	□130					□180	
Rated Output	[kW]	0.9	1.5	2.2	3	3	5
Rated Torque	[N·m]	2.86	4.77	7	9.55	9.55	15.91
	[kgf·cm]	29.2	48.7	71.4	97.4	97.4	162.3
Max. Instantaneous Torque	[N·m]	8.59	14.32	21.01	28.65	28.65	47.74
	[kgf·cm]	87.7	146.1	214.3	292.2	292.3	487
Rated Current	[A]	6.45	9.15	13.24	16.09	15.26	26.47
Max. Current	[A]	19.35	27.45	39.72	48.27	45.78	79.41
Rated Speed	[r/min]	3000					
Max. Speed	[r/min]	5000					
Inertia Moment	[kg·m ² X10 ⁻⁴]	5.66	10.18	14.62	19.04	27.96	46.56
	[gf·cm·s ²]	5.77	10.39	14.92	19.43	28.53	47.51
Allowable Load Inertia Ratio		10 times of motor inertia				5 times of motor inertia	
Rated Power Rate	[kW/s]	14.47	22.38	33.59	47.85	32.59	54.33
Speed/Position Detector	Standard	Serial Type 19[Bit]					
	Option	×					
Specifications & Features	Protection	Fully closed-Self cooling IP65 <small>Note1</small>					
	Rated Time	Continuous					
	Ambient Temp	Operating : 0 ~ 40[°C] Storage : -10 ~ 60[°C]					
	Ambient Humidity	Operating : Below 80[%]RH / Storage : Below 90[%]RH(Noncondensing)					
	Atmosphere	Avoid direct sunlight and corrosive / flammable gas or liquid.					
	Vibration Resistance	Vibration acceleration 49[m/s ²](5G)					
Weight	[kg]	5	6.7	8.5	10.1	12.5	17.4

Note1) Axis penetration not included. The IP rating for attached reducers is not guaranteed. Cables may not qualify marked IP rating if bent beyond designated specifications. Use specific cables for IP rating qualification.

Speed-Torque Characteristics

- 3 Phase AC200V
- 3Phase AC230V

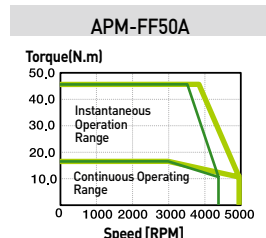
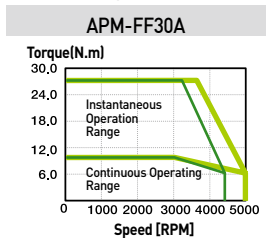
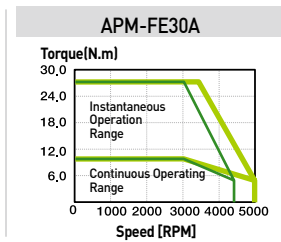
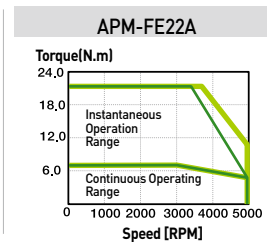
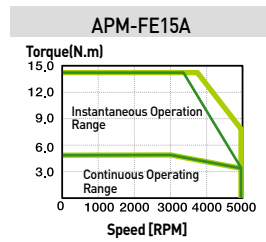
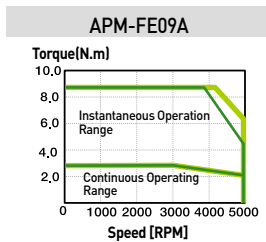

Motor Specifications [Rated 2000r/min]

Servo Motor (APM-□□□□)		FE06D	FE11D	FE16D	FE22D
Applicable Drive		L7□A008	L7□A010	L7□A020	
Flange Size(□)		□130			
Rated Output	[kW]	0.6	1.1	1.6	2.2
	[N·m]	2.86	5.25	7.63	10.5
Rated Torque	[kgf·cm]	29.20	53.6	77.9	107.1
	[N·m]	8.59	15.75	22.92	31.51
Max. Instantaneous Torque	[kgf·cm]	87.7	160.7	233.8	321.4
	[A]	4.56	6.47	10.98	12.97
Max. Current	[A]	13.68	19.41	32.94	38.91
Rated Speed	[r/min]	2000			
Max. Speed	[r/min]	3000			
Inertia Moment	[kg·m ² ×10 ⁻⁴]	5.66	10.18	14.62	19.04
	[gf·cm·s ²]	5.77	10.39	14.92	19.43
Allowable Load Inertia Ratio		10 times of motor inertia			
Rated Power Rate	[kW/s]	14.49	27.08	39.89	57.9
Speed/Position Detector	Standard	Serial Multi-Turn Type(19bit)			
	Option	×			
Specifications & Features	Protection	Fully closed-Self cooling IP65 <small>Note1</small>			
	Rated Time	Continuous			
	Ambient Temp	Operating : 0 ~ 40[°C] Storage : -10 ~ 60[°C]			
	Ambient Humidity	Operating : Below 80[%]RH / Storage : Below 90[%]RH(Noncondensing)			
	Atmosphere	Avoid direct sunlight and corrosive / flammable gas or liquid.			
Vibration Resistance	Vibration acceleration 49[m/s ²](5G)				
	Weight [kg]	5	6.7	8.5	10.1

Note1) Axis penetration not included. The IP rating for attached reducers is not guaranteed. Cables may not qualify marked IP rating if bent beyond designated specifications. Use specific cables for IP rating qualification.

Speed-Torque Characteristics

- 3 Phase AC200V
- 3Phase AC230V

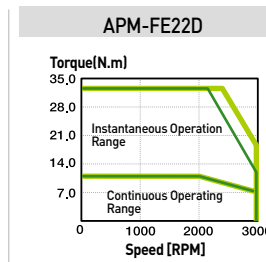
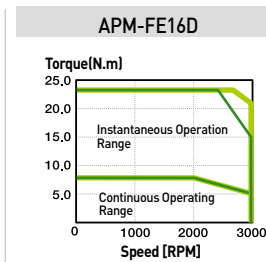
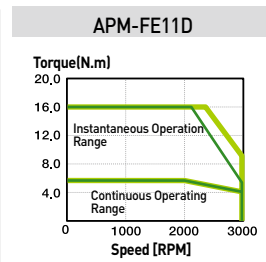
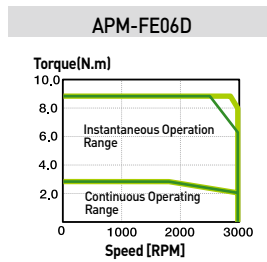

Motor Specifications [Rated 2000r/min]

Servo Motor [APM-□□□□□]	FF22D	FF35D	FF55D	FF75D	FG22D	FG35D	FG55D	FG75D	FG110D	
Applicable Drive	L7□A020	L7□A035	L7□A050	L7□A075	L7□A020	L7□A035	L7□A050	L7□A075	L7□A150	
Flange Size[□]	□180				□220					
Rated Output	[kW]	2.2	3.5	5.5	7.5	2.2	3.5	5.5	7.5	11
Rated Torque	[N·m]	10.5	16.7	26.25	35.81	10.5	16.71	26.25	35.81	52.52
	[kgf·cm]	107.1	170.4	267.8	365.4	107.1	170.4	267.8	365.4	535.9
Max. Instantaneous Torque	[N·m]	31.5	50.1	78.76	89.53	31.51	50.12	78.76	89.53	157.55
	[kgf·cm]	321.3	511.4	803.4	913.5	321.3	511.3	803.4	913.5	1607.60
Rated Current	[A]	13.07	16.48	28.78	32.95	10.25	14.67	29.74	30.17	51.39
Max. Current	[A]	39.21	49.44	86.34	82.38	30.75	44.01	89.22	75.43	154.17
Rated Speed	[r/min]	2000								
Max. Speed	[r/min]	3000			2500	3000	2700	3000	2500	
Inertia Moment	[kg·m ² ×10 ⁻⁴]	27.96	46.56	73.85	106.7	41.13	71.53	117.52	149.4	291.36
	[gf·cm·s ²]	28.53	47.51	75.36	108.9	41.97	72.99	120.12	152.45	297.31
Allowable Load Inertia Ratio		5 times of motor inertia								
Rated Power Rate	[kW/s]	39.43	59.89	93.27	120.15	26.78	38.99	58.51	85.83	94.65
Speed/Position Detector	Standard	Serial Type(19bit)								
	Option	×								
Specifications & Features	Protection	Fully closed-Self cooling IP65 <small>Note1</small>								
	Rated Time	Continuous								
	Ambient Temp	Operating : 0 ~ 40[°C] Storage : -10 ~ 60[°C]								
	Ambient Humidity	Operating : Below80[%]RH / Storage : Below 90[%]RH(Noncondensing)								
	Atmosphere	Avoid direct sunlight and corrosive / flammable gas or liquid.								
Vibration Resistance		Vibration acceleration 49[m/s ²][5G]								
	[kg]	12.5	17.4	25.12	33.8	15.4	20.2	28.12	33.45	66.2

Note1 Axis penetration not included. The IP rating for attached reducers is not guaranteed. Cables may not qualify marked IP rating if bent beyond designated specifications. Use specific cables for IP rating qualification.

Speed-Torque Characteristics

■ 3 Phase AC200V

■ 3 Phase AC230V

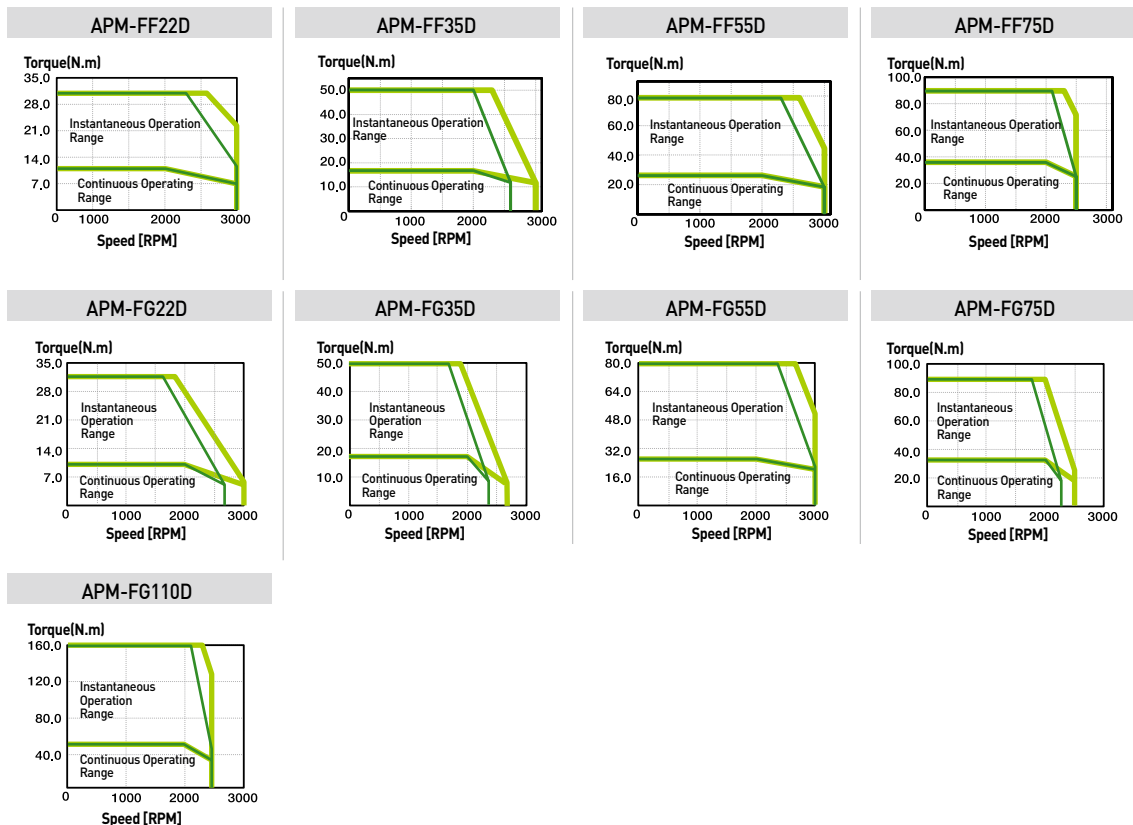

Motor Specifications [Rated 1500r/min]

Servo Motor (APM-□□□□□)	FE05G	FE09G	FE13G	FE17G	FF20G	FF30G	FF44G	FF60G	FF75G	FG20G	FG30G	FG44G	FG60G	FG85G	FG110G	FG150G	
Applicable Drive	L7□A008 L7□A010		L7□A020		L7□A020 L7□A035		L7□A050 L7□A075		L7□A075 L7□A075		L7□A020 L7□A035		L7□A050 L7□A075		L7□A150		
Flange Size(□)	□130						□180						□220				
Rated Output [kW]	0.45	0.85	1.3	1.7	1.8	2.9	4.4	6	7.5	1.8	2.9	4.4	6	8.5	11	15	
Rated Torque [N·m]	2.86	5.41	8.27	10.82	11.45	18.46	28	38.2	47.7	11.5	18.5	28	38.2	54.11	69.99	95.45	
[kgf·cm]	29.22	55.19	84.41	110.38	116.9	188.3	285.7	389.8	487.2	116.9	188.4	285.8	389.7	552.1	714.2	974	
Max. Instantaneous Torque [N·m]	8.59	16.23	24.82	32.46	34.35	55.38	78.4	95.5	119.3	34.4	55.4	78.4	95.5	162.32	209.97	238.63	
[kgf·cm]	87.66	165.57	253.23	331.14	350.6	564.9	799.6	974.9	1217.3	350.8	565.1	800.24	974.3	1656.30	2142.60	2435	
Rated Current [A]	4.56	6.67	11.9	13.36	12.16	15.98	30.7	35.14	35.26	11.18	16.21	31.72	32.18	52.94	59.3	75.6	
Max.Current [A]	13.68	20.01	35.7	40.08	36.48	47.94	85.96	87.85	88.15	33.54	48.63	88.82	96.54	158.82	177.9	189	
Rated Speed [r/min]	1500																
Max. Speed [r/min]	3000				3000	2700	3000	2500	2200	2700			3000	2500	2500	2000	2000
Inertia Moment [kg·m ² ×10 ⁻⁴]	5.66	10.18	14.62	19.04	27.96	46.56	73.85	106.7	131.3	41.13	71.53	117.72	149.4	291.36	291.36	424.57	
[gf·cm·s ²]	5.77	10.39	14.92	19.43	28.53	47.51	75.36	108.9	134	41.97	72.99	120.12	152.45	297.31	297.31	416.08	
Allowable Load Inertia Ratio	10 times of motor inertia								5 times of motor inertia								
Rated Power Rate [kW/s]	14.49	28.74	46.81	61.46	46.92	73.14	106.15	136.73	173.63	31.91	47.66	66.64	97.63	100.48	168.27	223.44	
Speed/Position Detector	Standard Serial Type 19[bit]																
Option	×																
Protection	Fully closed-Self cooling IP65 <small>Note1</small>																
Rated Time	Continuous																
Ambient Temp	Operating : 0 ~ 40[°C] Storage : -10 ~ 60[°C]																
Ambient Humidity	Operating : Below 80[%]RH / Storage : Below 90[%]RH(Noncondensing)																
Atmosphere	Avoid direct sunlight and corrosive / flammable gas or liquid.																
Vibration Resistance	Vibration acceleration 49[m/s ²][5G]																
Weight [kg]	5.0	6.7	8.5	10.1	12.5	17.4	25.2	33.8	38.5	15.4	20.2	28	33.45	66.2	66.3	92.2	

Note1) Axis penetration not included. The IP rating for attached reducers is not guaranteed. Cables may not qualify marked IP rating if bent beyond designated specifications. Use specific cables for IP rating qualification.

Speed-Torque Characteristics

- 3 Phase AC200V
- 3 Phase AC230V

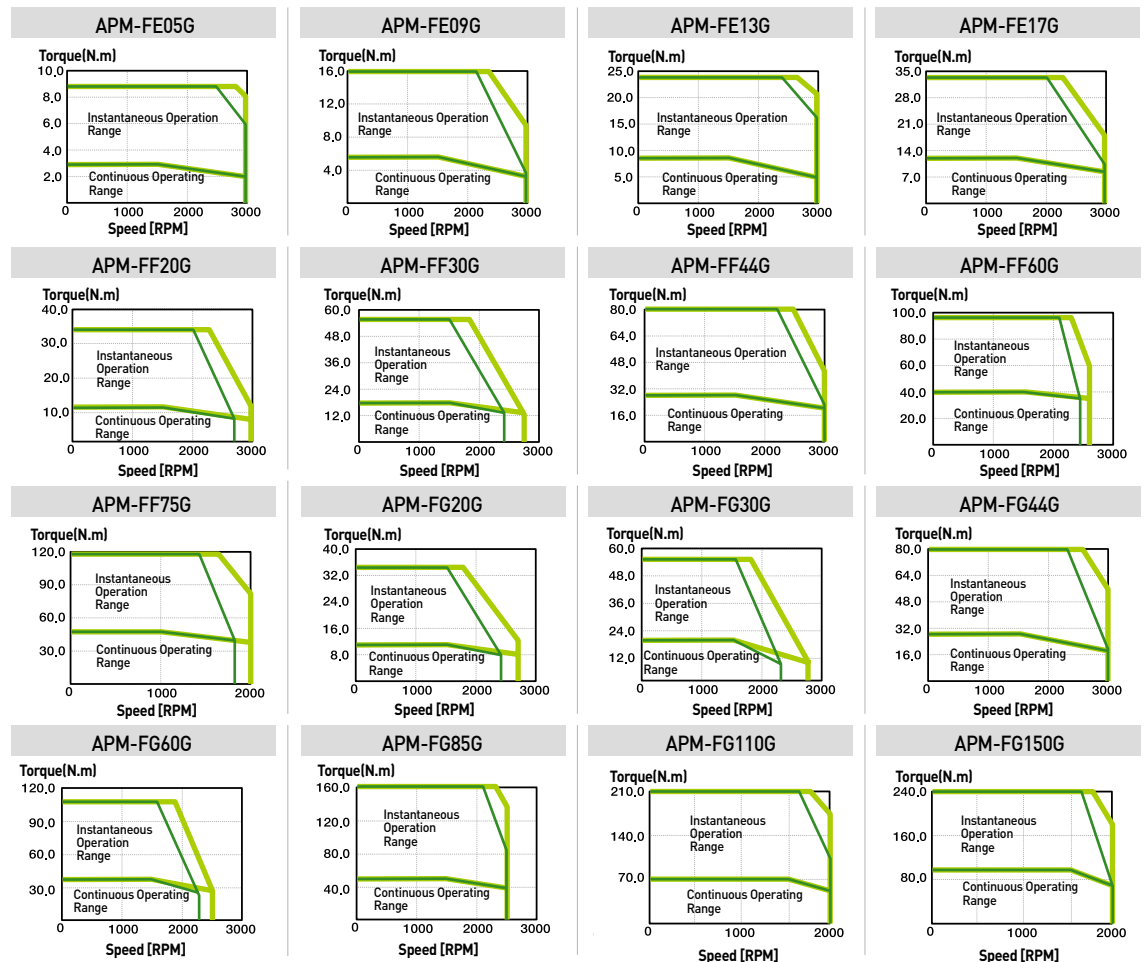

Servo Motor

Motor Specifications [Rated 1000r/min]

Servo Motor [APM-□□□□]	FE03M	FE06M	FE09M	FE12M	FF12M	FF20M	FF30M	FF44M	FG12M	FG20M	FG30M	FG44M	FG60M	
Applicable Drive	L7□A004	L7□A008	L7□A010		L7□A020		L7□A035	L7□A050		L7□A020	L7□A035	L7□A050	L7□A075	
Flange Size [□]	□130				□180				□220					
Rated Output [kW]	0.3	0.6	0.9	1.2	1.2	2	3	4.4	1.2	2	3	4.4	6.0	
Rated Torque	[N·m]	2.86	5.72	8.59	11.46	11.46	19.09	28.64	42.02	11.5	19.1	28.6	42	57.29
	[kgf·cm]	29.22	58.4	87.7	116.9	116.9	194.8	292.2	428.7	116.9	194.9	292.3	428.7	584.6
Max. Instantaneous Torque	[N·m]	8.59	17.18	25.77	34.22	34.38	57.29	85.94	105.05	34.4	57.3	85.9	126	143.2
	[kgf·cm]	87.66	175.3	262.9	349.1	350.7	584.4	876.6	1071.52	350.8	584.6	876.9	1286.1	1432.4
Rated Current [A]	2.73	4.56	6.18	10.67	11.01	12.96	16.58	30.6	11.28	13.1	15.52	27.26	39.32	
Max. Current [A]	8.19	13.68	18.54	32.01	33.03	38.88	49.74	85.68	33.84	39.3	46.56	81.78	98.30	
Rated Speed [r/min]	1000													
Max. Speed [r/min]	2000					1700			2000			1600	1900	2000
Inertia Moment	[kg·m ² ×10 ⁻⁴]	5.66	10.18	14.62	19.04	27.96	46.56	73.85	106.7	41.13	71.53	117.72	149.4	291.36
	[gf·cm·s ²]	5.77	10.39	14.92	19.43	28.53	47.51	75.36	108.9	41.97	72.99	120.12	152.45	297.31
Allowable Load Inertia Ratio	10 times of motor inertia						5 times of motor inertia							
Rated Power Rate [kW/s]	14.49	32.22	50.48	68.91	46.94	78.27	111.04	165.38	31.91	51	69.7	118.14	112.65	
Speed/Position Detector	Standard	Serial Type 19[bit]												
	Option	×												
Specifications & Features	Protection	Fully closed-Self cooling IP65 <small>Note1</small>												
	Rated Time	Continuous												
	Ambient Temp	Operating : 0 ~ 40[°C] Storage : -10 ~ 60[°C]												
	Ambient Humidity	Operating : Below 80[%]RH / Storage : Below 90[%]RH(Noncondensing)												
	Atmosphere	Avoid direct sunlight and corrosive / flammable gas or liquid.												
	Vibration Resistance	Vibration acceleration 49[m/s ²][5G]												
Weight [kg]	5.0	6.7	8.5	10.1	12.5	17.4	25.2	33.8	15.4	20.2	28	33.5	66.2	

Note1 Axis penetration not included. The IP rating for attached reducers is not guaranteed. Cables may not qualify marked IP rating if bent beyond designated specifications. Use specific cables for IP rating qualification.

Speed-Torque Characteristics

■ 3 Phase AC200V

■ 3 Phase AC230V

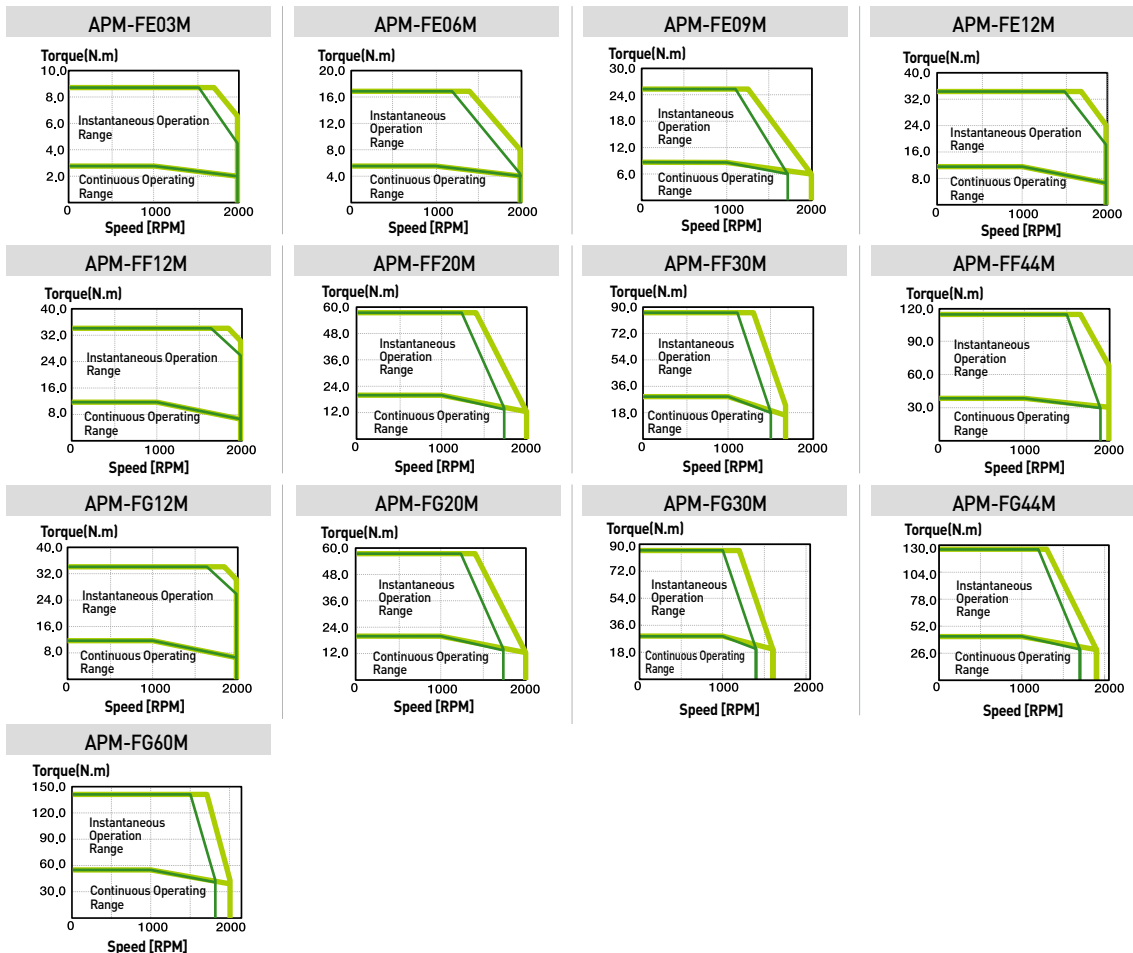

Motor Specifications [Rated 3000r/min]

Servo Motor [APM-□□□□□]	FEP09A	FEP15A	FEP22A	FEP30A	FFP30A	FFP50A	
Applicable Drive	L7□B010□	L7□B020□		L7□B035□		L7□B050□	
Flange Size[□]	□130			□180			
Rated Output	[kW]	0.9	1.5	2.2	3	3	5
Rated Torque	[N·m]	2.86	4.77	7	9.55	9.55	15.92
	[kgf·cm]	29.23	48.72	71.46	97.44	97.44	162.4
Max. Instantaneous Torque	[N·m]	8.59	14.32	21.01	28.65	28.65	39.79
	[kgf·cm]	87.7	146.16	214.37	292.33	292.33	406.01
Rated Current	[A]	3.47	6.68	7.64	9.94	9.79	16.07
Max. Current	[A]	10.4	20.03	22.92	29.81	29.38	40.18
Rated Speed	[r/min]	3000					
Max. Speed	[r/min]	5000					
Inertia Moment	[kg·m ² X10 ⁻⁴]	5.659	10.179	14.619	19.04	27.96	46.56
	[gf·cm·s ²]	5.774	10.387	14.917	19.429	28.531	47.51
Allowable Load Inertia Ratio		10 times of motor inertia			5 times of motor inertia		
Rated Power Rate	[kW/s]	14.5	22.4	33.55	47.89	32.61	54.4
Speed/Position Detector	Standard	Serial Type 19[bit]					
	Option	x					
Specifications & Features	Protection	Fully closed-Self cooling IP65 ^{Note1}					
	Rated Time	Continuous					
	Ambient Temp	Operating : 0 ~ 40[°C] Storage : -10 ~ 60[°C]					
	Ambient Humidity	Operating : Below 80[%]RH / Storage : Below 90[%]RH(Noncondensing)					
	Atmosphere	Avoid direct sunlight and corrosive / flammable gas or liquid.					
	Vibration Resistance	Vibration acceleration 49[m/s ²][5G]					
Weight	[kg]	5.5	7.54	9.68	11.78	12.4	17.7

Note1) Axis penetration not included. The IP rating for attached reducers is not guaranteed. Cables may not qualify marked IP rating if bent beyond designated specifications. Use specific cables for IP rating qualification.

Speed-Torque Characteristics

- 3Phase AC200V
- 3Phase AC230V

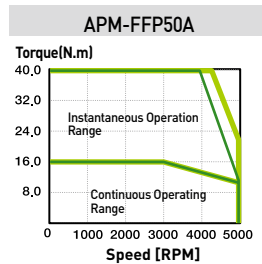
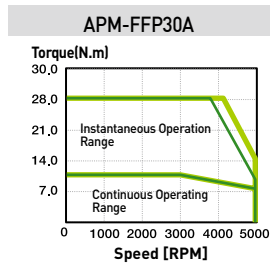
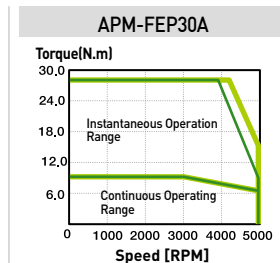
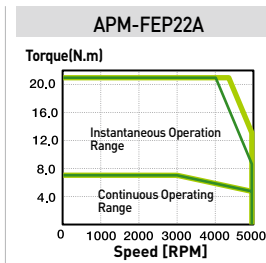
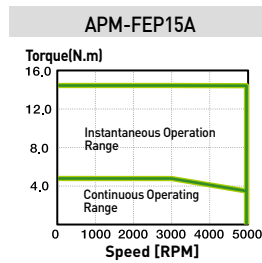
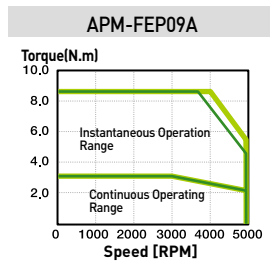

Motor Specifications [Rated 2000r/min]

Servo Motor [APM-□□□□□]	FEP06D	FEP11D	FEP16D	FEP22D	FFP22D	FFP35D	FFP55D	FFP75D	FGP22D	FGP35D	FGP55D	FGP75D	FGP110D	
Applicable Drive	L7□B010□		L7□B020□		L7□B035□		L7□B050□		L7□B075□		L7□B100□		L7□B150□	
Flange Size[□]	□130				□180				□220					
Rated Output	[kW]	0.6	1.1	1.6	2.2	2.2	3.5	5.5	7.5	2.2	3.5	5.5	7.5	11
Rated Torque	[N·m]	2.86	5.25	7.64	10.5	10.5	16.71	26.26	35.81	10.5	16.71	26.26	35.81	52.52
	[kgf·cm]	29.23	53.59	77.95	107.19	107.19	170.52	267.96	365.41	107.19	170.52	267.96	365.41	535.93
Max. Instantaneous Torque	[N·m]	8.59	15.76	22.92	31.51	31.51	50.13	65.65	89.52	31.51	50.13	65.65	89.52	131.30
	[kgf·cm]	87.7	160.78	233.86	321.56	321.56	511.57	669.84	913.52	321.56	511.57	669.84	913.52	1339.69
Rated Current	[A]	3.28	3.4	4.97	6.80	6.93	9.09	14.70	18.97	7.12	8.73	16.04	19.10	27.41
Max. Current	[A]	9.83	10.19	14.92	20.4	20.8	27.26	36.75	47.42	21.35	26.2	40.1	47.76	68.52
Rated Speed	[r/min]	2000												
Max. Speed	[r/min]	3000				2700			2500	3000	2700	3000	2500	
Inertia Moment	[kg·m ² ×10 ⁻⁴]	5.659	10.179	14.619	19.04	27.96	46.56	73.85	106.73	41.13	71.53	117.72	149.4	291.36
	[gf·cm·s ²]	5.774	10.387	14.917	19.429	28.531	47.51	75.357	108.908	41.97	72.99	120.12	152.45	297.31
Allowable Load Inertia Ratio		10 times of motor inertia					5 times of motor inertia							
Rated Power Rate	[kW/s]	14.5	27.1	39.92	57.95	39.46	59.98	93.38	120.15	26.83	39.04	58.58	85.83	94.68
Speed/Position Detector	Standard	Serial Type 19[bit]												
	Option	×												
Specifications & Features	Protection	Fully closed-Self cooling IP65 <small>Note1</small>												
	Rated Time	Continuous												
	Ambient Temp	Operating : 0 ~ 40[°C] Storage : -10 ~ 60[°C]												
	Ambient Humidity	Operating : Below 80[%]RH / Storage : Below 90[%]RH(Noncondensing)												
	Atmosphere	Avoid direct sunlight and corrosive / flammable gas or liquid.												
Vibration Resistance		Vibration acceleration 49[m/s ²][5G]												
	Weight [kg]	5.5	7.54	9.68	11.78	12.4	17.7	26.3	35.6	16.95	21.95	30.8	37.52	66.2

Note1 Axis penetration not included. The IP rating for attached reducers is not guaranteed. Cables may not qualify marked IP rating if bent beyond designated specifications. Use specific cables for IP rating qualification.

Speed-Torque Characteristics

- 3 Phase AC200V
- 3 Phase AC230V

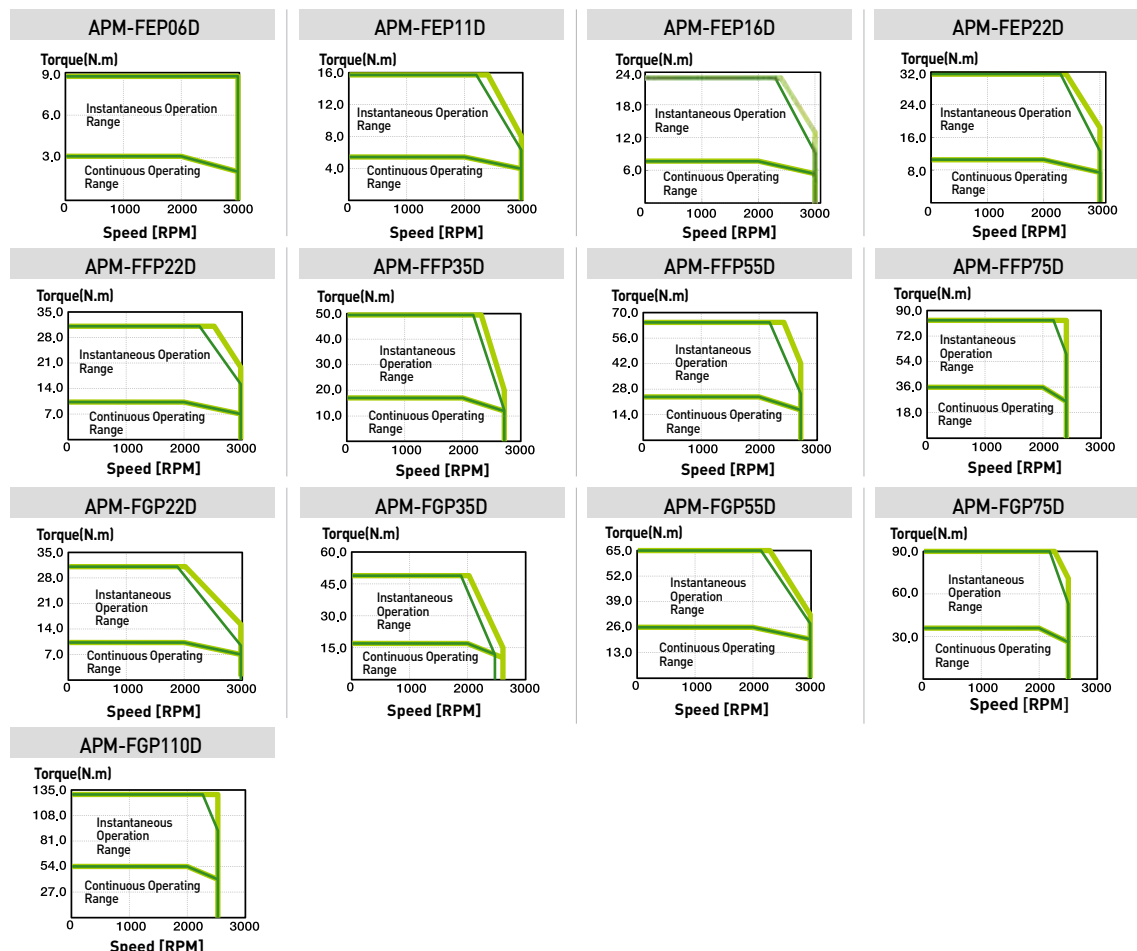

Motor Specifications [Rated 1500r/min]

Servo Motor (APM-□□□□□)	FEP05G	FEP09G	FEP13G	FEP17G	FFP20G	FFP30G	FFP44G	FFP60G	FFP75G	FGP20G	FGP30G	FGP44G	FGP60G	FGP85G	FGP110G	FGP150G	
Applicable Drive	L7□B010□		L7□B020□			L7□B035□ L7□B050□		L7□B075□		L7□B020□ L7□B035□ L7□B050□ L7□B075□		L7□B150□					
Flange Size(□)	□130					□180					□220						
Rated Output	[kW]	0.45	0.85	1.3	1.7	1.8	2.9	4.4	6	7.5	1.8	2.9	4.4	6	8.5	11	15
	[N·m]	2.86	5.41	8.28	10.82	11.46	18.46	28.01	38.2	47.75	11.46	18.46	28.01	38.2	54.11	70.03	95.49
Rated Torque	[kgf·cm]	29.23	55.22	84.45	110.43	116.93	188.39	285.83	389.77	487.21	116.93	188.39	285.83	389.77	552.17	714.57	974.42
	[N·m]	8.59	16.23	24.83	32.47	34.38	55.39	70.02	95.49	119.37	34.38	55.39	70.03	95.49	135.28	175.07	238.73
Max. Instantaneous Torque	[kgf·cm]	87.7	166.65	253.35	331.3	350.79	565.16	714.48	974.42	1,218.02	350.79	565.16	714.57	974.42	1,380.43	1,786.43	2,436.05
	[N·m]	8.59	16.23	24.83	32.47	34.38	55.39	70.02	95.49	119.37	34.38	55.39	70.03	95.49	135.28	175.07	238.73
Rated Current	[A]	3.28	3.50	5.39	7.01	7.56	10.04	15.68	20.23	20.01	7.76	9.65	17.11	20.38	28.24	28.02	35.71
Max. Current	[A]	9.83	10.5	16.16	21.02	22.69	30.12	39.20	50.58	50.03	23.29	28.95	46.19	50.95	70.6	70.05	89.25
Rated Speed	[r/min]	1500															
Max. Speed	[r/min]	3000				2700		2700	2500	2200	3000	2700	3000	2500	2000		
Inertia Moment	[kg·m ² ×10 ⁻⁴]	5.659	10.179	14.619	19.04	27.96	46.56	73.85	106.73	131.29	41.13	71.53	117.72	149.4	291.36	291.36	385.05
	[gf·cm ²]	5.774	10.387	14.917	19.429	28.531	47.51	75.357	108.98	133.969	41.97	72.99	120.12	152.45	297.31	297.31	392.91
Allowable Load Inertia Ratio		10 times of motor inertia					5 times of motor inertia										
Rated Power Rate	[kW/s]	14.5	28.77	46.85	61.52	46.96	73.21	106.25	136.7	173.64	25.53	47.65	66.65	97.66	100.5	168.3	236.82
Speed/Position Detector	Standard	Serial Type 19[bit]															
	Option	×															
Specifications & Features	Protection	Fully closed-Self cooling IP65 <small>Note1</small>															
	Rated Time	Continuous															
	Ambient Temp	Operating : 0 ~ 40[°C] Storage : -10 ~ 60[°C]															
	Ambient Humidity	Operating : Below 80[%]RH / Storage : Below 90[%]RH(Noncondensing)															
	Atmosphere	Avoid direct sunlight and corrosive / flammable gas or liquid.															
Weight	Vibration Resistance	Vibration acceleration 49[m/s ²](5G)															
	[kg]	5.5	7.54	9.68	11.78	12.4	17.7	26.3	35.6	39.4	16.95	21.95	30.8	37.52	66.2	66.3	92.2

Note1 Axis penetration not included. The IP rating for attached reducers is not guaranteed. Cables may not qualify marked IP rating if bent beyond designated specifications. Use specific cables for IP rating qualification.

Speed-Torque Characteristics

- 3Phase AC200V
- 3Phase AC230V

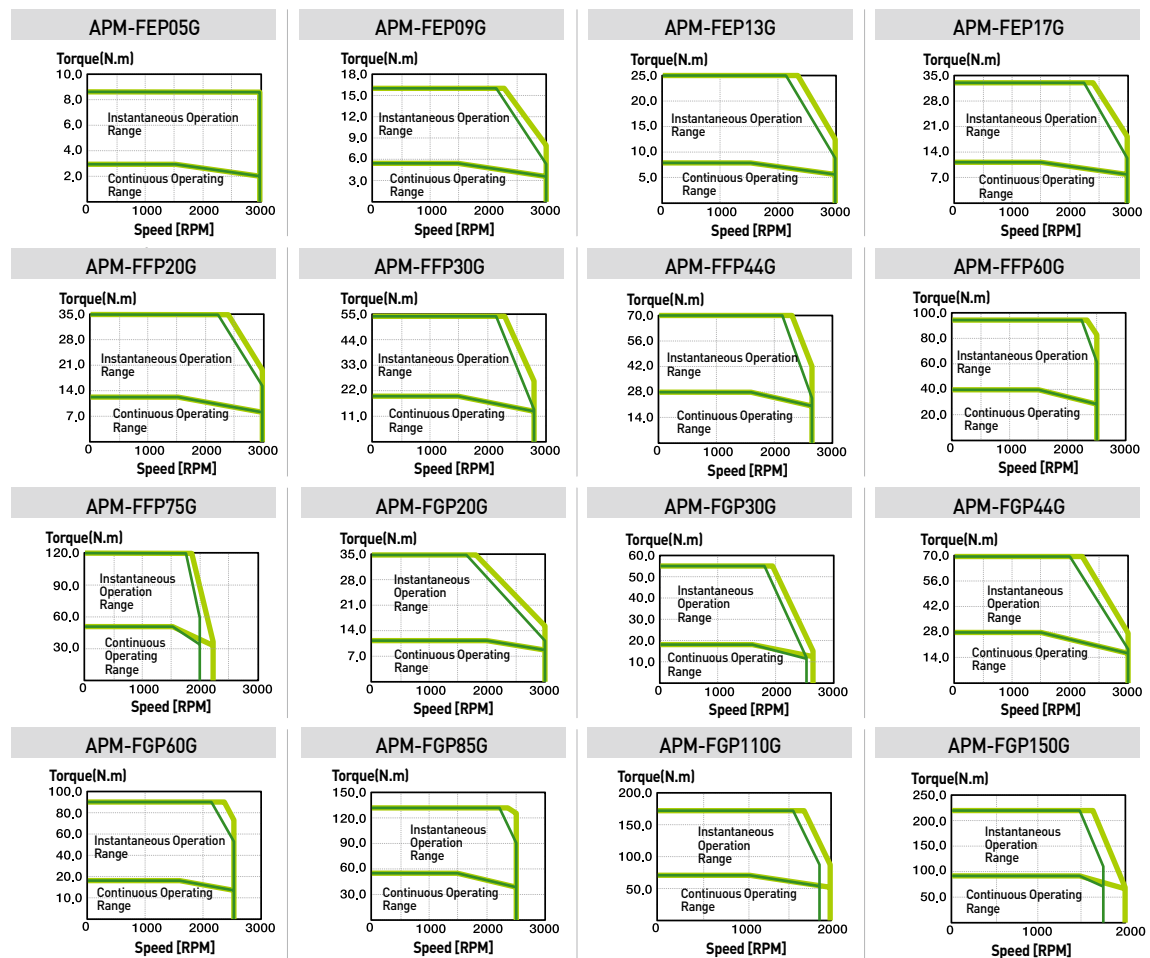

Servo Motor

Motor Specifications [Rated 1000r/min]

Servo Motor (APM-□□□□□)	FEP03M	FEP06M	FEP09M	FEP12M	FFP12M	FFP20M	FFP30M	FFP44M	FGP12M	FGP20M	FGP30M	FGP44M	FGP60M			
Applicable Drive	L7□B010□				L7□B020□				L7□B035□ L7□B050□		L7□B020□		L7□B035□ L7□B050□ L7□B075□			
Flange Size (□)	□130				□180				□220							
Rated Output [kW]	0.3	0.6	0.9	1.2	1.2	2	3	4.4	1.2	2	3	4.4	6.0			
Rated Torque	[N·m]	2.86	5.73	8.59	11.46	11.46	19.1	28.65	42.02	11.46	19.1	28.65	42.02	57.30		
	[kgf·cm]	29.23	58.47	87.7	116.93	116.93	194.88	292.33	428.74	116.93	194.88	292.33	428.74	584.65		
Max. Instantaneous Torque	[N·m]	8.59	17.19	25.78	34.38	34.38	57.3	71.62	105.05	34.38	57.3	85.94	105.05	143.24		
	[kgf·cm]	87.7	175.4	263.09	350.79	350.79	584.65	730.81	1071.85	350.79	584.65	876.98	1071.86	1461.63		
Rated Current [A]	3.28	3.28	3.33	4.87	4.83	7.94	9.97	16.69	4.75	7.88	9.97	17.39	20.23			
Max. Current [A]	9.83	9.83	9.99	14.6	14.5	23.83	29.91	41.73	14.24	23.64	29.91	43.48	49.69			
Rated Speed [r/min]	1000															
Max. Speed [r/min]	2000						1800		2000			1800		2000		1900
Inertia Moment	[kg·m ² ×10 ⁻⁴]	5.659	10.179	14.619	19.04	27.96	46.56	73.85	106.73	41.13	71.53	117.72	149.4	291.36		
	[gf·cm·s ²]	5.774	10.387	14.917	19.429	28.531	47.51	75.357	108.908	41.969	72.99	120.12	152.45	297.31		
Allowable Load Inertia Ratio	10 times of motor inertia						5 times of motor inertia									
Rated Power Rate [kW/s]	14.5	32.25	50.53	68.97	46.96	78.34	111.13	165.41	31.93	50.99	54.93	118.17	112.64			
Speed/Position Detector	Standard	Serial Type 19[bit]														
	Option	×														
Specifications & Features	Protection	Fully closed · Self cooling IP65 <small>Note1)</small>														
	Rated Time	Continuous														
	Ambient Temp	Operating : 0 ~ 40[°C] Storage : -10 ~ 60[°C]														
	Ambient Humidity	Operating : Below 80[%]RH / Storage : Below 90[%]RH (Noncondensing)														
	Atmosphere	Avoid direct sunlight and corrosive / flammable gas or liquid.														
Vibration Resistance	Vibration acceleration 49[m/s ²]{5G}															
	Weight [kg]	5.5	7.54	9.68	11.78	12.4	17.7	26.3	35.6	16.95	21.95	30.8	37.52	66.2		

Note1) Axis penetration not included. The IP rating for attached reducers is not guaranteed. Cables may not qualify marked IP rating if bent beyond designated specifications. Use specific cables for IP rating qualification.

Speed-Torque Characteristics

■ 3Phase AC200V

■ 3Phase AC230V

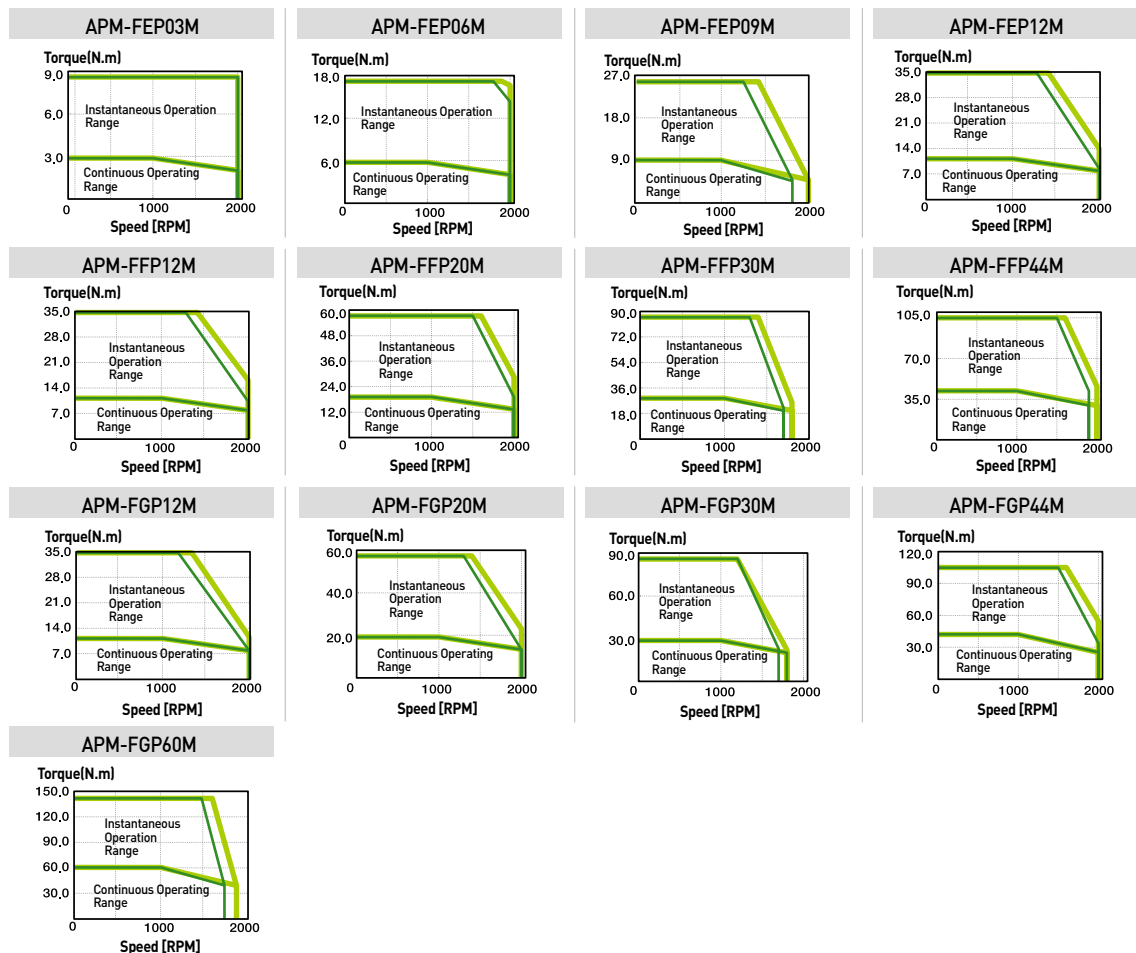

PHOX DC Drive Motor Specifications

Servo Motor (APMC-□□□□□□□-8)	FAL01A-8	FBL01A-8	FBL02A-8	FBL03A-8
Applicable Drive	PHOX-03		PHOX-06	PHOX-06 ^{Note1)}
Flange Size(□)	□40	□60	□60	□60
Rated Output	[kW]	0.1	0.1	0.2
Rated Torque	[N·m]	0.32	0.32	0.64
	[kgf·cm]	3.25	3.25	6.49
Max. Instantaneous Torque	[N·m]	0.96	0.96	1.92
	[kgf·cm]	9.74	9.74	19.48
Rated Current	[A]	2.71	2.5	5.54
Max. Current	[A]	8.13	7.50	16.62
Rated Speed	[r/min]	3000		
Max. Speed	[r/min]	5000	5000	5000
Inertia Moment	[kg·m ² ×10 ⁻⁴]	0.042	0.091	0.147
	[gf·cm·s ²]	0.043	0.093	0.15
Allowable Load Inertia Ratio	30 times of motor inertia		20 times of motor inertia	
Rated Power Rate	[kW/s]	24.24	11.13	27.57
Speed/Position Detector	Standard	Serial Multi-Turn Built-in Type(18bit)	Serial Multi-Turn Built-in Type(19bit)	
	Option	x		
Specifications & Features	Protection	Fully closed · Self cooling IP67 ^{Note2)}		
	Rated Time	Continuous		
	Ambient Temp	Operating : 0 ~ 40[°C] Storage : -10 ~ 60[°C]		
	Ambient Humidity	Operating : Below 80[%]RH / Storage : Below 90[%]RH(Noncondensing)		
	Atmosphere	Avoid direct sunlight and corrosive / flammable gas or liquid.		
Vibration Resistance	Vibration acceleration 49[m/s ²][5G]			
Weight	[kg]	0.45	0.56	0.74

^{Note1)} If you need to apply PHOX-06 drive to a motor, please contact us.

^{Note2)} Axis penetration not included. The IP rating for attached reducers is not guaranteed. Cables may not qualify marked IP rating if bent beyond designated specifications. Use specific cables for IP rating qualification.

Speed-Torque Characteristics

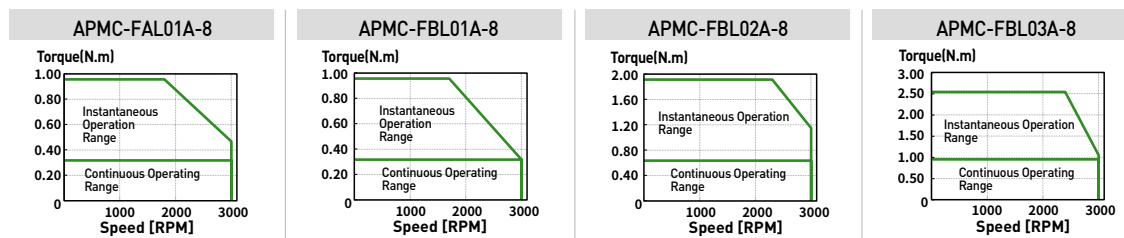

※ The graph above shows the rotational speed-torque characteristics when the drive input power is DC 48[V].

FAL Series

Plug Specifications

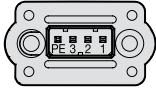

Power

Pin No.	Signal
1	U
2	V
3	W
PE	Ground

(Power Connector Pin Table)

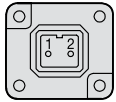

Brake

Pin No.	Signal
1	BK+
2	BK-

(Brake Connector Pin Table)

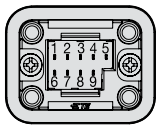

Encoder

Multi Turn (M)	
Pin No.	Signal
1	MA
2	SLO
3	GND_B
4	OV
5	SHIELD
6	MA
7	SLO
8	VDD_B
9	+5V

(Encoder Connector Pin Table)

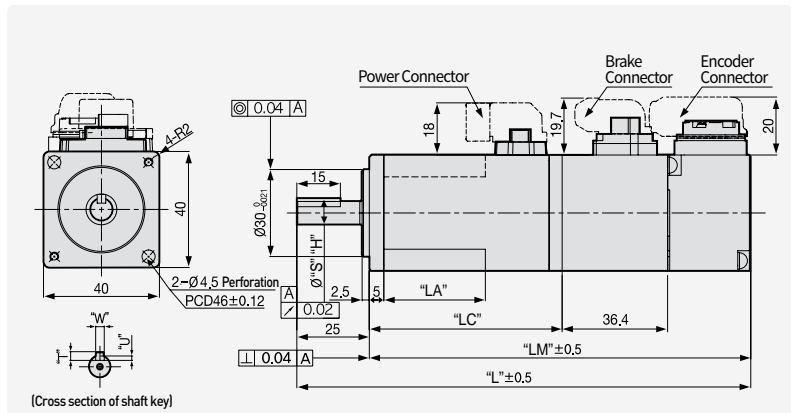

(Cross section of shaft key)

Model	External Dimensions(mm)						Key Dimensions			Weight (kg)
	L	LM	LC	LA	S	H	T	W	U	
FALR5A	103.2(139.6)	78.2(114.6)	49.5	23	8	$0_{-0.009}^0$	3	3	1.8	0.31(0.66)
FAL01A	120.2(156.6)	95.2(131.6)	66.5	35	8	$0_{-0.009}^0$	3	3	1.8	0.45(0.80)
FAL015A	140.2	115.2	86.5	35	8	$0_{-0.009}^0$	3	3	1.8	0.61

Note1) Use DC[24V] for brake input power supply.

Note2) Dimensions in parantheses are for brake-attached type.

Note3) The FAL Type can only draw towards front.

FBL Series

Plug Specifications

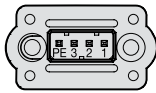

Power

Pin No.	Signal
1	U
2	V
3	W
PE	Ground

(Power Connector Pin Table)

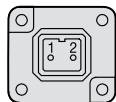

Brake

Pin No.	Signal
1	BK+
2	BK-

(Brake Connector Pin Table)

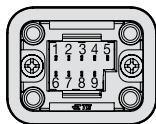

Encoder

Multi Turn (M)	
Pin No.	Signal
1	MA
2	SLO
3	GND_B
4	OV
5	SHIELD
6	MA
7	SLO
8	VDD_B
9	+5V

(Encoder Connector Pin Table)

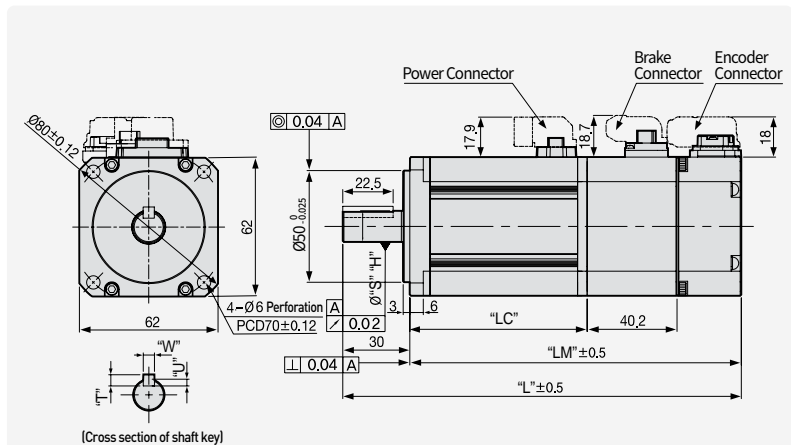

(Cross section of shaft key)

Model	External Dimensions(mm)						Key Dimensions			Weight (kg)
	L	LM	LC	S	H	T	W	U		
FBL01A	107.2(147.2)	77.2(117.2)	48.5(48.3)	14	$0_{-0.018}^0$	5	5	3	0.56(1.3)	
FBL02A	118.2(158.2)	88.2(128.2)	59.5(59.3)	14	$0_{-0.018}^0$	5	5	3	0.74(1.48)	
FBL04A	138.2(178.2)	108.2(148.2)	79.5(79.3)	14	$0_{-0.018}^0$	5	5	3	1.06(1.8)	

Note1) Use DC[24V] for brake input power supply.

Note2) Dimensions in parantheses are for brake-attached type.

Note3) For external dimensions of oil-sealed type, please contact us separately.

FCL Series

Plug Specifications

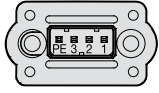

Power	
Pin No.	Signal
1	U
2	V
3	W
PE	Ground

[Power Connector Pin Table]

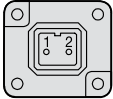

Brake	
Pin No.	Signal
1	BK+
2	BK-

[Brake Connector Pin Table]

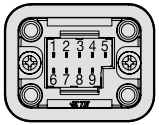

Encoder	
Multi Turn (M)	
Pin No.	Signal
1	MA
2	SLO
3	GND_B
4	OV
5	SHIELD
6	MA
7	SLO
8	VDD_B
9	+5V

[Encoder Connector Pin Table]

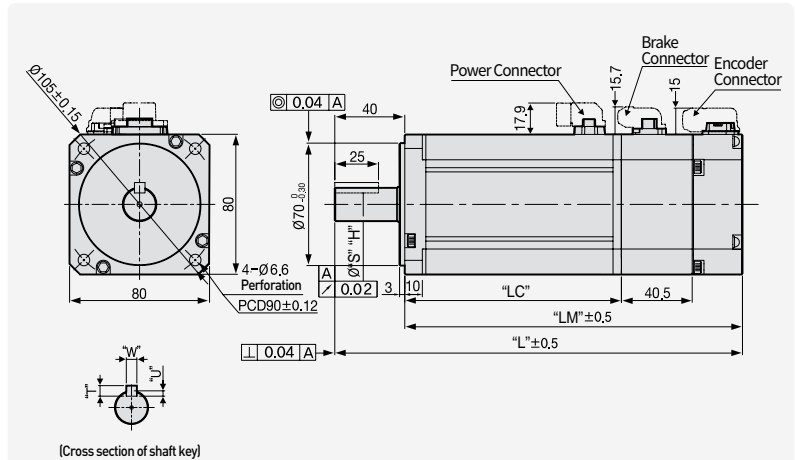

Model	External Dimensions(mm)				Key Dimensions			Weight (kg)	
	L	LM	LC	S	H	T	W		U
FCL04A, FCL03D	138.7(179)	98.7(139)	70(69.8)	14	0 ^{-0.018}	5	5	3	1.52(2.32)/1.26(2.06)
FCL06A, FCL05D	156.7(197)	116.7(157)	88(87.8)	19	0 ^{-0.021}	6	6	3.5	2.14(2.94)/2.12(2.92)
FCL08A, FCL06D	174.7(215)	134.7(175)	106(105.8)	19	0 ^{-0.021}	6	6	3.5	2.68(3.48)/2.66(3.46)
FCL10A, FCL07D	192.7(233)	152.7(193)	124(123.8)	19	0 ^{-0.021}	6	6	3.5	3.30(4.10)/2.78(3.58)

- Note1) Use DC[24V] for brake input power supply.
- Note2) Dimensions in parantheses are for brake-attached type.
- Note3) For external dimensions of oil-sealed type, please contact us separately.

FE, FEP Series

Plug Specifications

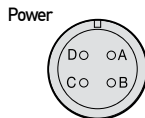

Power	
Pin No.	Signal
A	U
B	V
C	W
D	Ground

Spec.: MS3102A20-4P (Standard)

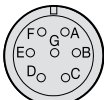

Spec.: MS3102A20-15P (Brake-attached type)

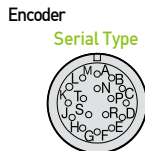

Spec.: MS3102A20-29P

Pin No.	Signal	Pin No.	Signal
A	U	D	Ground
B	V	E	BK+
C	W	F	BK-

Encoder			
Pin No.	Signal	Pin No.	Signal
A	MA	M	-
B	MA	N	-
C	SLO	P	-
D	SLO	R	-
E	-	H	+5V
F	-	G	OV
K	-	J	SHIELD
L	-	-	-

[Single Turn Encoder Connector Pin Table]

Pin No.	Signal	Pin No.	Signal
A	MA	M	-
B	MA	N	-
C	SLO	P	-
D	SLO	R	-
E	VDD_B	H	+5V
F	GND_B	G	OV
K	-	J	SHIELD
L	-	-	-

[Multi Turn Encoder Connector Pin Table]

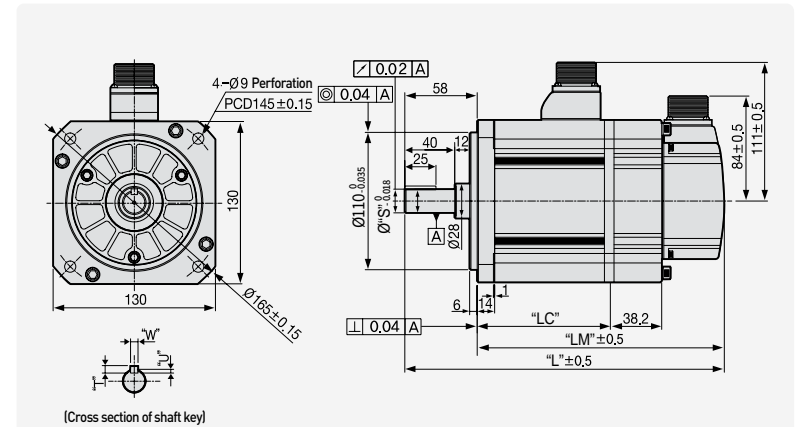

Model	External Dimensions(mm)				Key Dimensions			Weight (kg)
	L	LM	LC	S	T	W	U	
FE09A, FE06D, FE05G, FE03M, FEP09A, FEP06D, FEP05G, FEP03M	197.3(235.3)	139.3(177.3)	89.8(89.6)	19	5	5	3	5.04(6.58)
FE15A, FE11D, FE09G, FE06M, FEP15A, FEP11D, FEP09G, FEP06M	217.3(255.3)	159.3(197.3)	109.8(109.6)	19	5	5	3	6.74(8.28)
FE22A, FE16D, FE13G, FE09M, FEP22A, FEP16D, FEP13G, FEP09M	237.3(275.3)	179.3(217.3)	129.8(129.6)	22	6	6	3.5	8.48(10.02)
FE30A, FE22D, FE17G, FE12M, FEP30A, FEP22D, FEP17G, FEP12M	255.3(293.3)	197.3(235.3)	147.8(147.6)	24	7	8	4	10.05(11.59)

- Note1) Use DC[24V] for brake input power supply.
- Note2) Dimensions in parantheses are for brake-attached type.

FF, FFP Series Plug Specifications

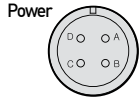

Spec.: MS3102A22-22P
(Standard)



Spec.: MS3102A24-10P
(Brake-attached type)

Encoder

Serial Type



Spec.: MS3102A20-29P

Power

Pin No.	Signal
A	U
B	V
C	W
D	Ground

Pin No.	Signal	Pin No.	Signal
A	U	D	Ground
B	V	E	BK+
C	W	F	BK-

Encoder

Pin No.	Signal	Pin No.	Signal
A	MA	M	-
B	MÄ	N	-
C	SLO	P	-
D	SLO	R	-
E	-	H	+5V
F	-	G	0V
K	-	J	SHIELD
L	-		

(Single Turn Encoder Connector Pin Table)

Pin No.	Signal	Pin No.	Signal
A	MA	M	-
B	MÄ	N	-
C	SLO	P	-
D	SLO	R	-
E	VDD_B	H	+5V
F	GND_B	G	0V
K	-	J	SHIELD
L	-		

(Multi Turn Encoder Connector Pin Table)

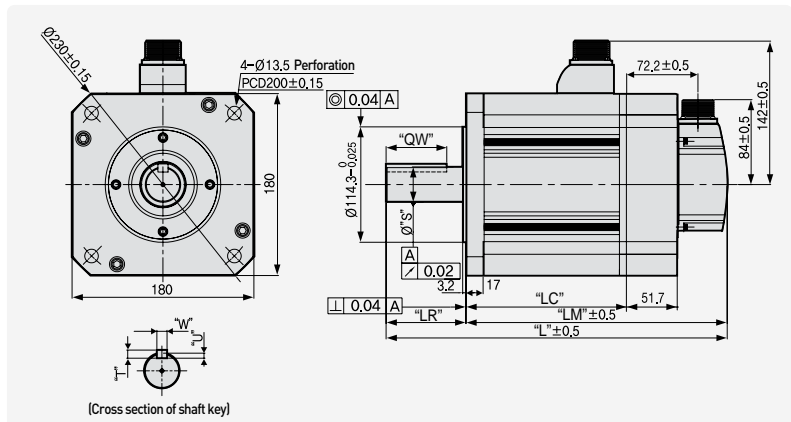

Model	External Dimensions(mm)				Key Dimensions					Weight (kg)
	L	LM	LC	LR	S	QW	T	W	U	
FF30A, FF22D, FF20G, FF12M, FFP30A, FFP22D, FFP20G, FFP12M	257.5 (308.9)	178.5 (229.9)	129 (128.7)							12.5 (19.7)
FF50A, FF35D, FF30G, FF20M, FFP50A, FFP35D, FFP30G, FFP20M	287.5 (338.9)	208.5 (259.9)	159 (158.7)	79	35 ^{+0.01} ₀	60	8	10	5	17.4 (24.6)
FF55D, FF44G, FF30M, FFP55D, FFP44G, FFP30M	331.5 (382.9)	252.5 (303.9)	203 (202.7)							25.2 (32.4)
FF75D, FF60G, FF44M, FFP75D, FFP60G, FFP44M	384.5 (435.9)	305.5 (356.9)	256 (255.7)		42 ⁰ _{0.016}			12		33.8 (41.0)
FF75G, FFP75G	439.5	326.5	277	113		96				38.5 (45.7)

Note1) This bolt applies to models FF30 and above.

Note2) Use DC(24V) for brake input power supply.

Note3) Dimensions in parantheses are for brake-attached type.

Note4) Use MS3102A32-17 for FF75G Power connector.

FG, FGP Series Plug Specifications

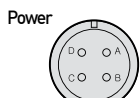

Spec.: MS3102A22-22P
(Standard)



Spec.: MS3102A14-7P
(Brake-attached type)

Encoder

Serial Type



Spec.: MS3102A20-29P

Power

Pin No.	Signal
A	U
B	V
C	W
D	Ground

Pin No.	Signal
A	BK+
B	BK-
C	NC

Encoder

Pin No.	Signal	Pin No.	Signal
A	MA	M	-
B	MÄ	N	-
C	SLO	P	-
D	SLO	R	-
E	-	H	+5V
F	-	G	0V
K	-	J	SHIELD
L	-		

(Single Turn Encoder Connector Pin Table)

Pin No.	Signal	Pin No.	Signal
A	MA	M	-
B	MÄ	N	-
C	SLO	P	-
D	SLO	R	-
E	VDD_B	H	+5V
F	GND_B	G	0V
K	-	J	SHIELD
L	-		

(Multi Turn Encoder Connector Pin Table)

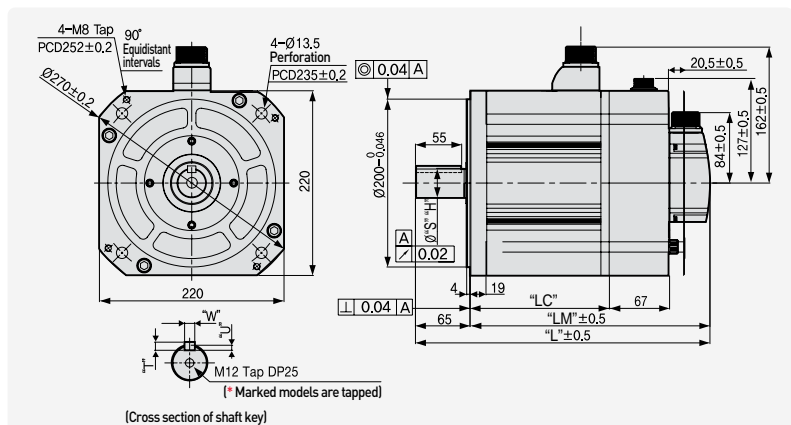

Model	External Dimensions(mm)				Key Dimensions					Weight (kg)	Power Connector
	L	LM	LC	S	H	T	W	U			
FG22D, FG20G, FG12M, FGP22D, FGP20G, FGP12M	229.5 (295.7)	164.5 (230.7)	115 (114.2)							15.42 (29.23)	
FG35D, FG30G, FG20M, FGP35D, FGP30G, FGP20M	250.5 (316.7)	185.5 (251.7)	136 (135.2)	35	0 ^{-0.016}		10	5		20.22 (34.03)	MS3102A 22-22P
FG55D, FG44G, FG30M, FGP55D, FGP44G, FGP30M	282.5 (348.7)	217.5 (283.7)	168 (167.2)			8				28.02 (41.83)	
FG75D, FG60G, FG44M, FGP75D, FGP60G, FGP44M	304.5 (370.7)	239.5 (305.7)	190 (189.2)	42	0 ^{-0.016}		12			33.45 (47.26)	
*FG110D, *FG85G, *FG60M, *FGP110D, *FGP85G	418.5 (484.7)	353.5 (305.7)	304 (303.2)	45	0 ^{-0.016}		10	6		66.2 (82.6)	MS3102A 32-17P

Note1) Use DC(24V) for brake input power supply. Note2) Dimensions in parantheses are for brake-attached type.

FG(P)110G

Plug Specifications

Power

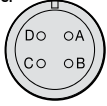

Spec.: MS3102A32-17P

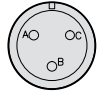

Spec.: MS3102A14-7P
(Brake-attached type)

Encoder

Serial type

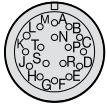

Spec.: MS3102A20-29P

Power

Pin No.	Signal
A	U
B	V
C	W
D	Ground

Pin No.	Signal
A	BK+
B	BK-
C	NC

Encoder

Pin No.	Signal	Pin No.	Signal
A	MA	M	-
B	MA	N	-
C	SLO	P	-
D	SLO	R	-
E	-	H	+5V
F	-	G	0V
K	-	J	SHIELD
L	-		

(Single Turn Encoder Connector Pin Table)

Pin No.	Signal	Pin No.	Signal
A	MA	M	-
B	MA	N	-
C	SLO	P	-
D	SLO	R	-
E	VDD_B	H	+5V
F	GND_B	G	0V
K	-	J	SHIELD
L	-		

(Multi Turn Encoder Connector Pin Table)

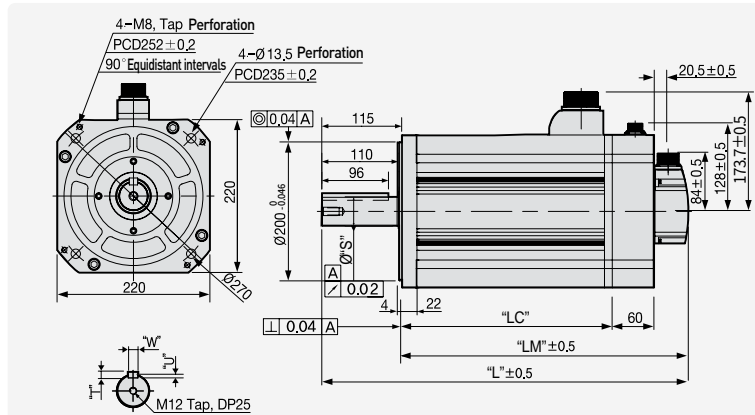

(Cross section of shaft key)

Model	External Dimensions(mm)			Key Dimensions				Weight (kg)	Power Connector
	L	LM	LC	S	T	W	U		
FG(P)110G	468.5 (527.7)	353.5 (419.7)	304 (303.2)	42 ⁰ _{0.016}	8	12	5	66.3 (82.7)	MS3102A 32-17P

Note1) Use DC[24V] for brake input power supply.

Note2) Dimensions in parantheses are for brake-attached type.

Note3) For external dimensions of oil-sealed type, please contact us separately.

FG(P)150G

Plug Specifications

Power

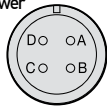

Spec.: MS3102A32-17P

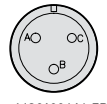

Spec.: MS3102A14-7P
(Brake-attached type)

Encoder

Serial type



Spec.: MS3102A20-29P

Power

Pin No.	Signal
A	U
B	V
C	W
D	접지선

Pin No.	Signal
A	BK+
B	BK-
C	NC

Encoder

Pin No.	Signal	Pin No.	Signal
A	MA	M	-
B	MA	N	-
C	SLO	P	-
D	SLO	R	-
E	-	H	+5V
F	-	G	0V
K	-	J	SHIELD
L	-		

(Single Turn Encoder Connector Pin Table)

Pin No.	Signal	Pin No.	Signal
A	MA	M	-
B	MA	N	-
C	SLO	P	-
D	SLO	R	-
E	VDD_B	H	+5V
F	GND_B	G	0V
K	-	J	SHIELD
L	-		

(Multi Turn Encoder Connector Pin Table)

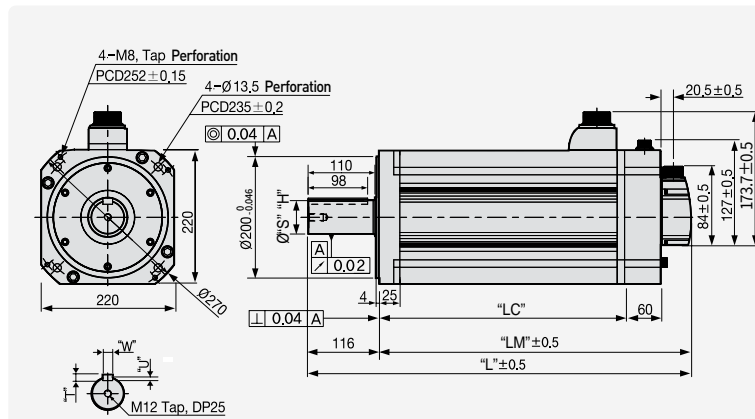

(Cross section of shaft key)

Model	External Dimensions(mm)			Key Dimensions				Weight (kg)	Power Connector
	L	LM	LC	S	H	T	W		
FG(P)150G	574 (630.5)	458 (514.5)	408 (405)	55	10	16	6	92.2 (108.6)	MS3102A 32-17P

Note1) Use DC[24V] for brake input power supply.

Note2) Dimensions in parantheses are for brake-attached type.

Motor Specifications (With Magnetic Encoder, Rated 3000r/min)

Servo Motor (APMC-□□□□□)	FALR5A	FAL01A	FAL015A ^{Note1)}	FBL01A	FBL02A	FBL04A	FCL04A	FCL06A	FCL08A	FCL10A	
Applicable Drive	L7CA001U		L7CA002U	L7CA001U	L7CA002U	L7CA004U		L7CA008U		L7CA010U	
Flange Size(□)	□40			□60			□80				
Rated Output	[kW]	0.05	0.1	0.15	0.1	0.2	0.4	0.4	0.6	0.75	1
Rated Torque	[N·m]	0.16	0.32	0.48	0.32	0.64	1.27	1.27	1.91	2.39	3.18
	[kgf·cm]	1.62	3.25	4.87	3.25	6.49	12.99	12.99	19.49	24.36	32.48
Max. Instantaneous Torque	[N·m]	0.48	0.96	1.43	0.96	1.91	3.82	3.82	5.73	7.16	9.55
	[kgf·cm]	4.87	9.74	14.62	9.74	19.48	38.96	38.98	58.47	73.08	97.44
Rated Current	[A]	0.95	1.25	1.60	0.95	1.45	2.6	2.58	3.81	5.02	5.83
Max. Current	[A]	2.85	3.75	4.80	2.85	4.35	7.8	7.75	11.42	15.07	17.5
Rated Speed	[r/min]	3000									
Max. Speed	[r/min]	5000									
Inertia Moment	[kg·m ² ×10 ⁻⁴]	0.023	0.042	0.063	0.091	0.147	0.248	0.53	0.897	1.264	1.632
	[gf·cm·s ²]	0.024	0.043	0.065	0.093	0.15	0.253	0.541	0.915	1.29	1.665
Allowable Load Inertia Ratio		30 times of motor inertia			20 times of motor inertia			15 times of motor inertia			
Rated Power Rate	[kW/s]	10.55	23.78	36.19	11.09	27.6	27.07	30.6	40.66	45.09	62.08
Speed/Position Detector	Standard	Serial Single - Turn Built - in Type (17bit)									
Specifications & Features	Protection	Fully closed:Self cooling IP67									
	Rated Time	Continuous									
	Ambient Temp	Operating : 0 ~ 40[°C] Storage : -10 ~ 60[°C]									
	Ambient Humidity	Operating : Below 80[%]RH / Storage : Below 90[%]RH(Noncondensing)									
	Atmosphere	Avoid direct sunlight and corrosive / flammable gas or liquid.									
	Vibration Resistance	Vibration acceleration 49[m/s ²] [5G]									
Weight	[kg]	0.31	0.45	0.61	0.56	0.74	1.06	1.52	2.14	2.68	3.3

Note1) Brake is not applicable for FAL015A

Speed-Torque Characteristics

- 3 Phase AC200V
- 3Phase AC230V

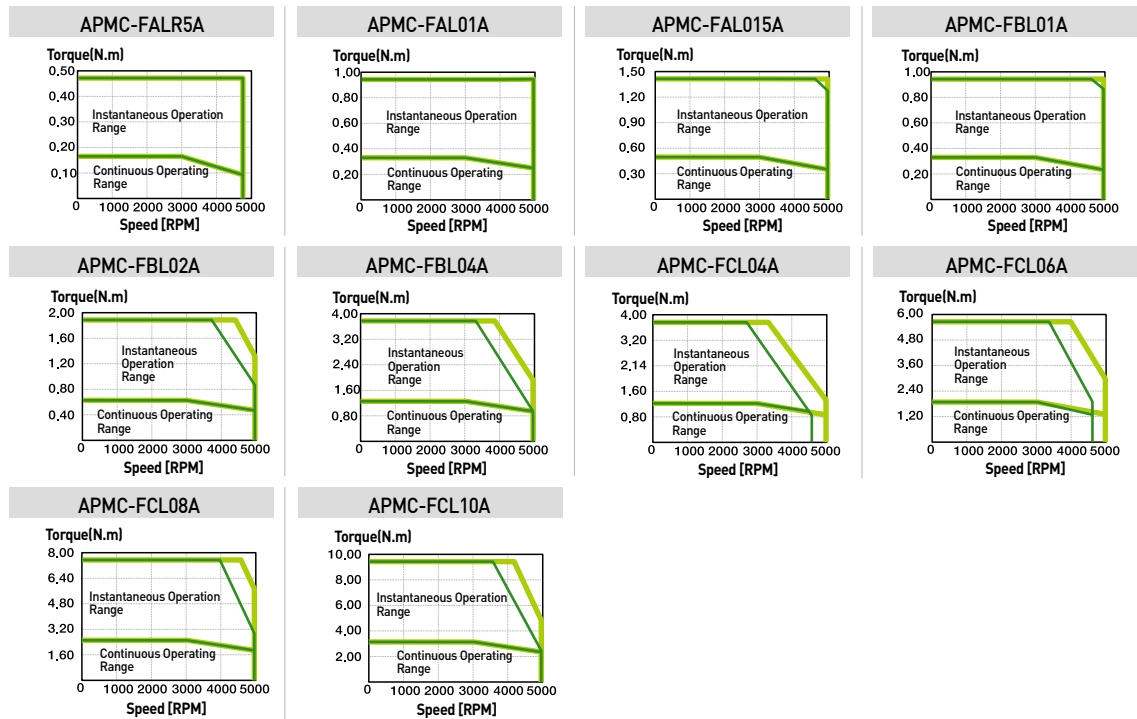

Motor Specifications (With Magnetic Encoder, Rated 2000r/min)

Servo Motor (APMC-□□□□□□)	FCL03D	FCL05D	FCL06D	FCL07D	
Applicable Drive	L7CA004U		L7CA008U		
Flange Size(□)	□80				
Rated Output	[kW]	0.3	0.45	0.55	0.65
Rated Torque	[N·m]	1.43	2.15	2.63	3.1
	[kgf·cm]	14.62	21.92	26.8	31.67
Max. Instantaneous Torque	[N·m]	4.3	6.45	7.88	9.31
	[kgf·cm]	43.85	65.77	80.39	95.01
Rated Current	[A]	2.5	3.05	3.06	3.83
Max. Current	[A]	7.51	9.16	9.18	11.5
Rated Speed	[r/min]	2000			
Max. Speed	[r/min]	3000			
Inertia Moment	[kg·m ² ×10 ⁻⁴]	0.53	0.897	1.264	1.63
	[gf·cm·s ²]	0.541	0.915	1.29	1.66
Allowable Load Inertia Ratio		15 times of motor inertia			
Rated Power Rate	[kW/s]	38.73	51.47	54.56	59.03
Speed/Position Detector	Standard	Serial Single - Turn Built - in Type (17bit)			
Specifications & Features	Protection	Fully closed-Self cooling IP67			
	Rated Time	Continuous			
	Ambient Temp	Operating : 0 ~ 40[°C] Storage : -10 ~ 60[°C]			
	Ambient Humidity	Operating : Below 80[%]RH / Storage : Below 90[%]RH(Noncondensing)			
	Atmosphere	Avoid direct sunlight and corrosive / flammable gas or liquid.			
	Vibration Resistance	Vibration acceleration 49[m/s ²] [5G]			
Weight	[kg]	1.26	2.12	2.66	2.78

Speed-Torque Characteristics

- 3 Phase AC200V
- 3Phase AC230V

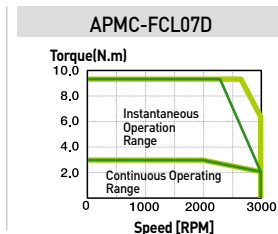
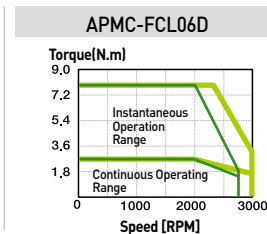
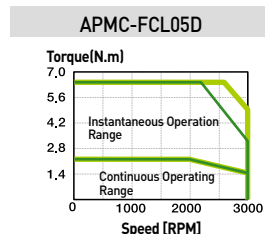
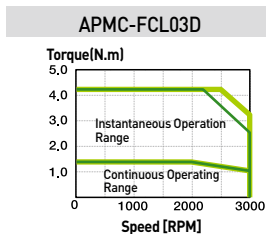

FAL Series with Magnetic Encoder

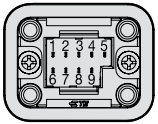
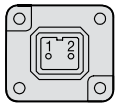
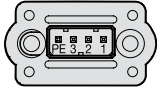

Plug Specifications

Power

Pin No.	Signal
1	U
2	V
3	W
PE	Ground

(Power Connector Pin Table)

Brake

Pin No.	Signal
1	BK+
2	BK-

(Brake Connector Pin Table)

Encoder

Single Turn (N)	
Pin No.	Signal
1	MA
2	SLO
3	-
4	OV
5	SHIELD
6	MA
7	SLO
8	-
9	+5V

(Encoder Connector Pin Table)

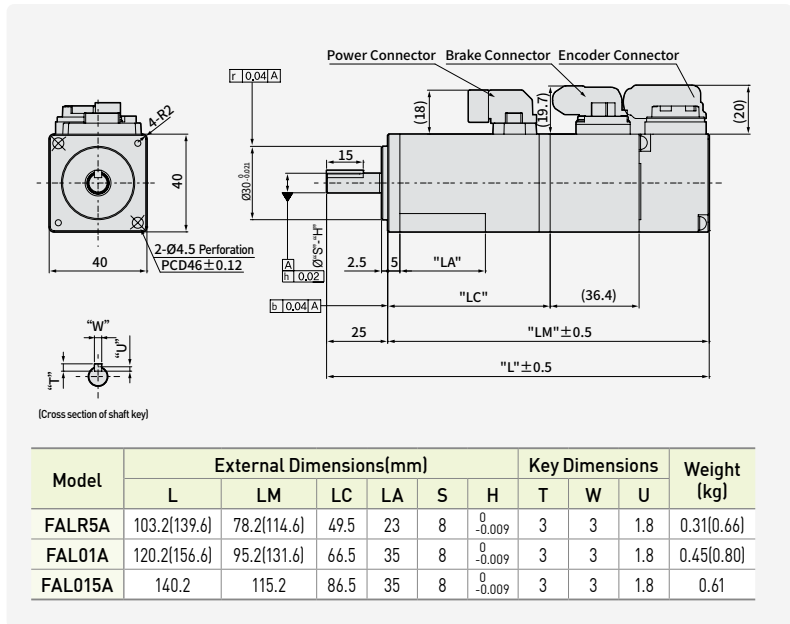

Note1) Use DC(24V) for brake input power supply.

Note2) Dimensions in parantheses are for brake-attached type.

Note3) For external dimensions of oil-sealed type, please contact us separately.

FBL Series with Magnetic Encoder

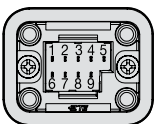
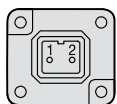
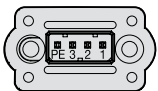

Plug Specifications

Power

Pin No.	Signal
1	U
2	V
3	W
PE	Ground

(Power Connector Pin Table)

Brake

Pin No.	Signal
1	BK+
2	BK-

(Brake Connector Pin Table)

Encoder

Single Turn (N)	
Pin No.	Signal
1	MA
2	SLO
3	-
4	OV
5	SHIELD
6	MA
7	SLO
8	-
9	+5V

(Encoder Connector Pin Table)

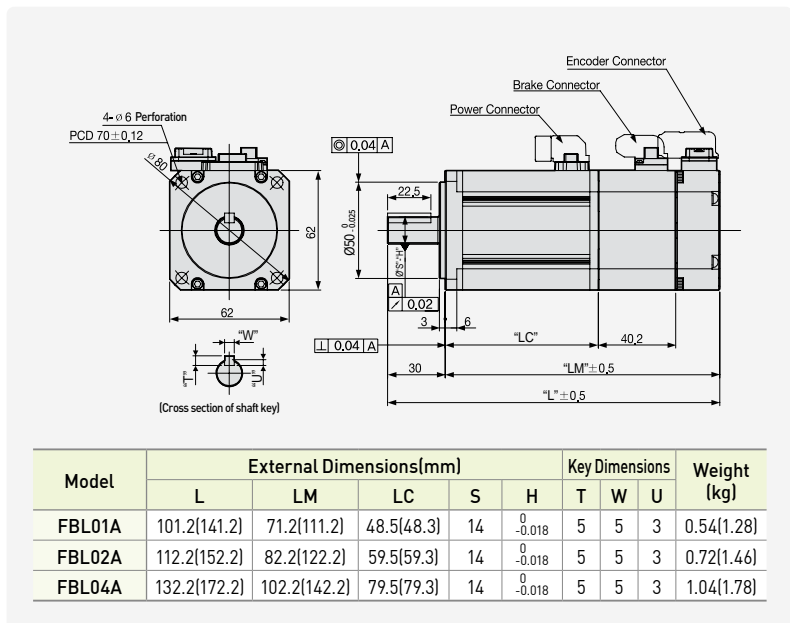

Note1) Use DC(24V) for brake input power supply.

Note2) Dimensions in parantheses are for brake-attached type.

FCL Series with Magnetic Encoder

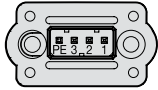

Plug Specifications

Power

Pin No.	Signal
1	U
2	V
3	W
PE	Ground

(Power Connector Pin Table)

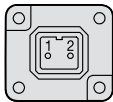

Brake

Pin No.	Signal
1	BK+
2	BK-

(Brake Connector Pin Table)

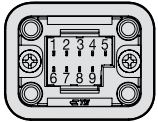

Encoder

Single Turn (N)	
Pin No.	Signal
1	MA
2	SLO
3	-
4	OV
5	SHIELD
6	MA
7	SLO
8	-
9	+5V

(Encoder Connector Pin Table)

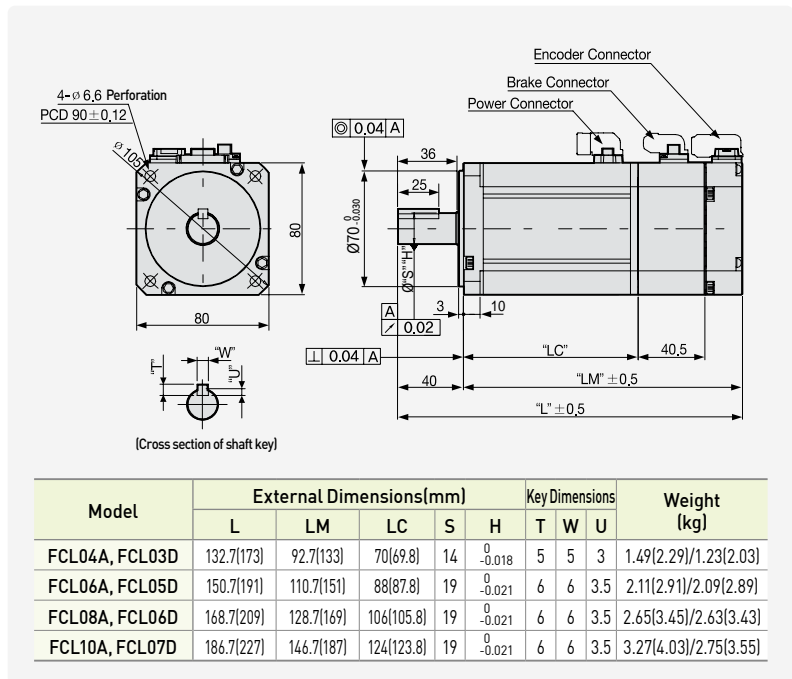

Note1) Use DC[24V] for brake input power supply.

Note2) Dimensions in parantheses are for brake-attached type.

Brake Specifications

Motor Series	FAL	FBL	FCL	FE/FEP	FF/FFP	FG/FGP	FG/FGP110G FG/FGP150G
Purpose	Maintenance	Maintenance	Maintenance	Maintenance	Maintenance	Maintenance	Maintenance
Input Voltage [V]	DC 24V	DC 24V	DC 24V	DC 24V	DC 24V	DC 90V	DC 24V
Static Friction Torque[Nm]	0.32	1.47	3.23	10.4	40	74	120
Capacity [W]	6	6.5	9	19.4	25	32	26
Coil Resistance [Ω]	96	67	64	29.6	23	257	18
Rated Current [A]	0.25	0.36	0.38	0.81	1.04	0.35	1.33
Insulation Class	F	F	F	F	F	F	F

Note1) All electromagnetic brakes built-in LS servo motors are of the same specification.

Note2) Electromagnetic brakes are for keeping the motors stationary. Do not use for braking operating motors.

Note3) Electromagnetic brake properties were measured at 20°C.

Note4) Specifications are subject to change. Please check your motor for voltage specifications.

Note5) Series FAL, FBL, FCL, FF and FFP comply with Class 2 Brake UL Standard.

Heat Sink Specifications

Classification	Standard(mm) Servo Motor	Material
AP04 (□40)	250×250×6	Aluminum
AP06 (□60)	250×250×6	
AP08 (□80)	250×250×12	
AP13 (□130)	350×350×20	
AP18 (□180)	550×550×30	
AP22 (□220)	650×650×35	

Note1) The data on the product features is measured when those heat sinks were applied.

Note2) Axis penetration not included.

Note3) The IP rating for attached reducers is not guaranteed.

Note4) Cables may not qualify marked IP rating if bent beyond designated specifications.

Note5) Use specific cables for IP rating qualification.

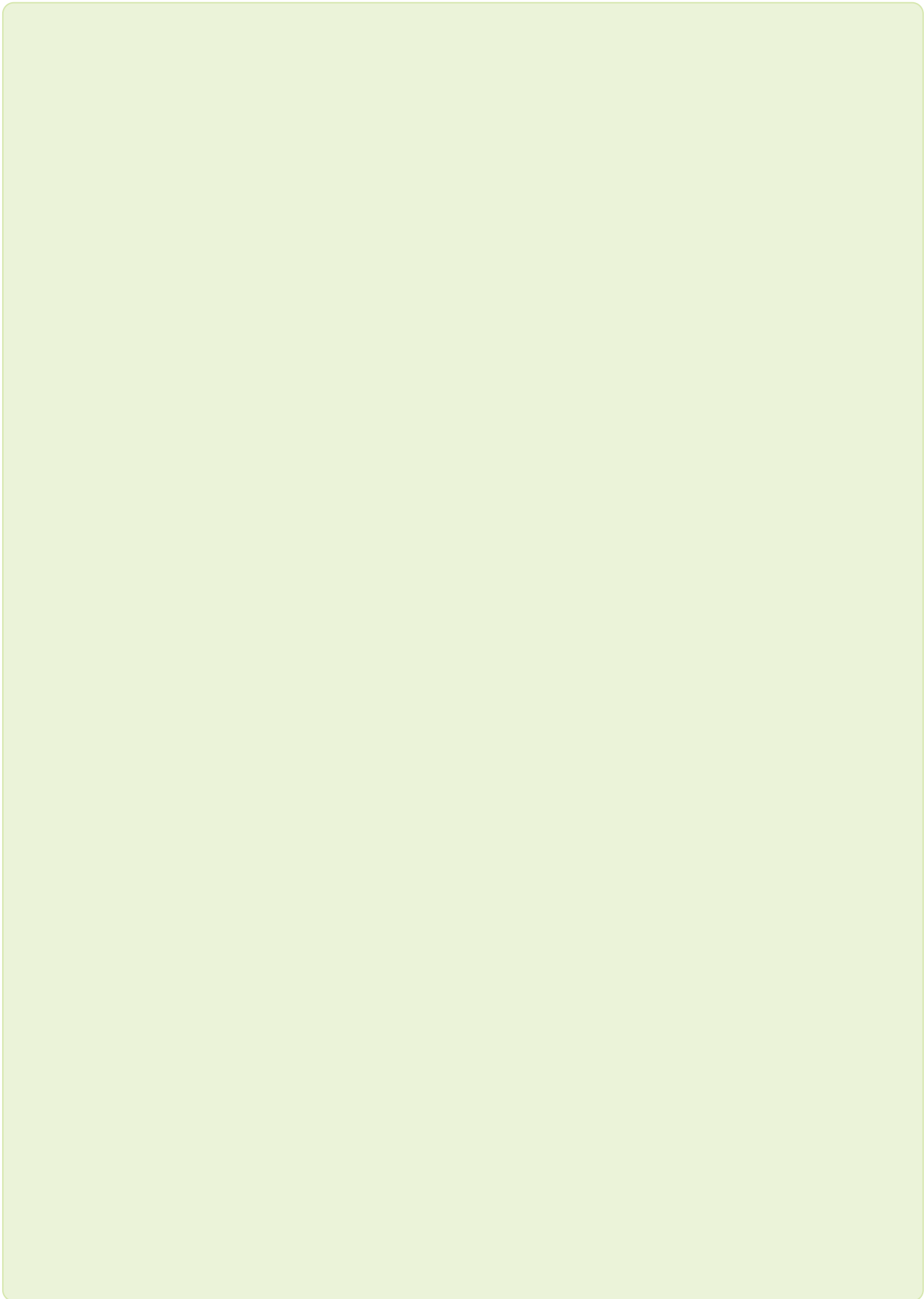

DD Motor Designation



We Use Our Own Technologies to Produce Motors, Drives and Encoders Domestically

Optimized for Low-speed, High-torque and High-precision Operation

- Power connection provided for the connection of DC-Link Terminal
- Compact Size and Easy Wiring (Compared with 3 phase AC Reactor)
- DC input connector provided (PI, N)

Reduced Cogging Torque and Optimized Torque Design

- Optimal ratio of the permanent magnet and coil / slot selected through electromagnetic analysis
- Multiple permanent magnets used to reduce torque ripple and to maximize torque
- Uses high-energy rare-earth permanent magnets (Nd-Fe-B)

High-performance rotary optical encoder with BiSS Protocol adoption used

- Resolution of 1,048,576 CPR (20bit Single turn)
- Using our own encoder technology to reduce the cost and shorten the delivery time

Compatible With Our L7 Series AC Servo Drive (3Phase AC 220V)

- Both standard I/O type (serial communication supported) and network type (EtherCAT) applicable

Direct Drive Structure

- No backlash impact
- High-precision operation and shortened installation time
- Smooth rotary motion
- Reduced noise

Hollow Type Efficient for Wiring and Piping

A Wide Range of Products

- Rated output: 63W - 2.5kW
- Rated torque: 3.0N·m-330N·m (The instantaneous maximum torque should be 3 times the rated torque)
- Rated speed: 50RPM-200RPM
- Frame diameter: 135mm, 175mm, 230mm, 290mm, 360mm and 380mm (14 models)

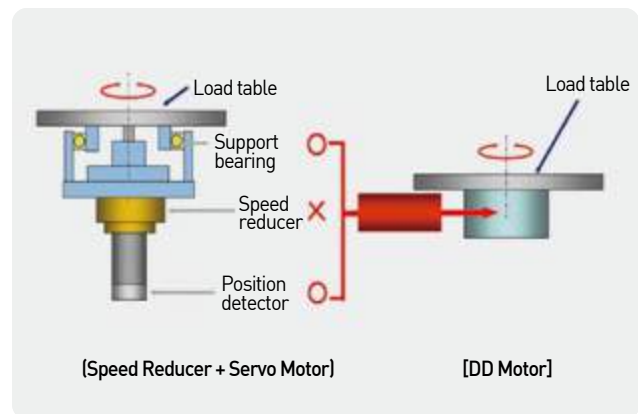
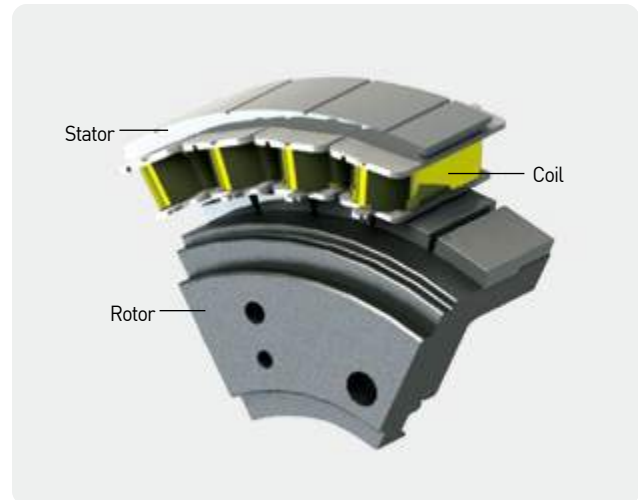









DD Motor Specifications

Ratings and Specifications

- Insulation class : Class B
- Protection class: IP 40
- Cooling type : Fully enclosed self-cooling
- Vibration class : V15
- Insulation resistance : 500 VDC, 10[MΩ] or higher
- Insulation withstand voltage: 1500VAC, 1 minute
- Operating voltage: 200 VAC
- Operating temperature: 0 - 40[°C] / Storage temperature: -10~60[°C]
- Ambient humidity: 20 - 80% RH (Noncondensing)
- Installation location: Place with no harmful substances such as corrosive / flammable gases, cutting fluid, metal dust or grease. Keep out of direct sunlight.

Line-up Table

Rated Torque[N·m]			3	6	9	12	18	22	34	40	60	110	160	330		
Max. Instantaneous Torque[Nm]			9	18	27	36	54	66	102	120	180	330	480	1000		
Rated Speed 200[rpm]	Maximum Speed 500[rpm]	Ø135	DB03D DB06D DB09D 													
		Ø175	DC06D 		DC12D 											
		Ø230			DD12D 											
	Maximum Speed 400[rpm]	Ø175				DC18D 										
		Ø230				DD22D DD34D 										
	Maximum Speed 300[rpm]	Ø290						DE40D DE60D 								
Rated Speed 150[rpm]	Maximum Speed 250[rpm]	Ø360							DFA1G DFA6G 							
Rated Speed 50[rpm]	Maximum Speed 100[rpm]	Ø380											DGC3S 			

Drive Combination Table

MDM Serial Type

Rated Speed (RPM)	Maximum Speed (RPM)	External Diameter of Motor(Ø)	Motor	Drive	Standard Encoders	Encoders Cable (Serial)	Power Cable (Power)		
200	500	135	DB03D	L7□A002□	APCS-P□□□YS	APCS-E□□□ZS	20Bit Serial (Single-turn Abs. BiSS interface)		
				iX7□A002□	APCS-P□□□YSX				
			DB06D	L7□A002□	APCS-P□□□YS				
				iX7□A002□	APCS-P□□□YSX				
			DB09D	L7□A004□	APCS-P□□□YS				
				iX7□A004□	APCS-P□□□YSX				
	175	DC06D	L7□A002□	APCS-P□□□YS					
			iX7□A002□	APCS-P□□□YSX					
		DC12D	L7□A004□	APCS-P□□□YS					
			iX7□A004□	APCS-P□□□YSX					
		DC18D	L7□A008□	APCS-P□□□YS					
			iX7□A008□	APCS-P□□□YSX					
	400	500	230	DD12D	L7□A004□			APCS-P□□□YS	
					iX7□A004□			APCS-P□□□YSX	
		400	230	DD22D	L7□A008□			APCS-P□□□YS	
					iX7□A008□			APCS-P□□□YSX	
					DD34D			L7□A010□	APCS-P□□□YS
								iX7□A010□	APCS-P□□□YSX
300	290	DE40D	L7□A010□	APCS-P□□□YS					
			iX7□A010□	APCS-P□□□YSX					
		DE60D	L7□A020□	APCS-P□□□YS					
			iX7□A020□	APCS-P□□□YSX					
			150	250	360	DFA1G	L7□A020□	APCS-P□□□ZS	
							iX7□A020□	APCS-P□□□ZSX	
DFA6G	L7□A035□	APCS-P□□□ZS							
	iX7□A35□	APCS-P□□□ZSX							
	50	100				380	DGC3S	L7□A020□	APCS-P□□□ZS
								iX7□A020□	APCS-P□□□ZSX

Servo Motor

Motor Shape



Motor Designation	MDM-DB□□□□□H-I			MDM-DC□□□□□H-I			
	03	06	09	06	12	18	
Applicable Drive	L7□A001□	L7□A002□	L7□A004□	L7□A002□	L7□A004□	L7□A008□	
Ext. Diameter of Motor	mm	Ø135			Ø175		
Rated Output	W	63	126	188	126	251	377
Rated Torque	N-m	3	6	9	6	12	18
Max Torque	N-m	9	18	27	18	36	54
Rated Current	Arms	1.12	1.46	2.63	1.48	2.41	3.0
Max Current	Arms	3.36	4.38	7.89	4.44	7.23	9.0
Rated Speed	rpm	200			200		
Max Speed	rpm	500	500	500	500	500	400
Torque Constant	N-m/Arms	2.76	4.25	3.57	4.18	5.13	6.12
Inertia Moment	kg·m ² ×10 ⁻⁴	11.56	18.42	26.02	45.83	70.37	94.91
Allowable Load Inertia Ratio		30 times of motor inertia			15 times of motor inertia		
Power Rate	kW/S	7.8	19.6	31.2	7.9	20.5	34.1
Positioning Accuracy	arc-sec	±30					
Positioning Repeatability	arc-sec	±1.3					
Axial run-out	mm	0.015					
Radial run-out	mm	0.03					
Allowable Thrust Load	N	1500			3300		
Allowable Moment Load	N-m	40			70		
Encoder Type		20-bit single turn serial encoder (Biss/Absolute)					
Weight(Approx.)	kg	5.2	6.8	8.9	7.4	9.8	12.0
Working Environment	Ambient Temp	Ambient temperature: 0~40[°C] / storage: -20~60[°C]					
	Ambient Humidity	20~80[%] RH(Noncondensing)					
	Atmosphere	Avoid direct sunlight and corrosive / flammable gas.					

Speed-Torque Characteristics

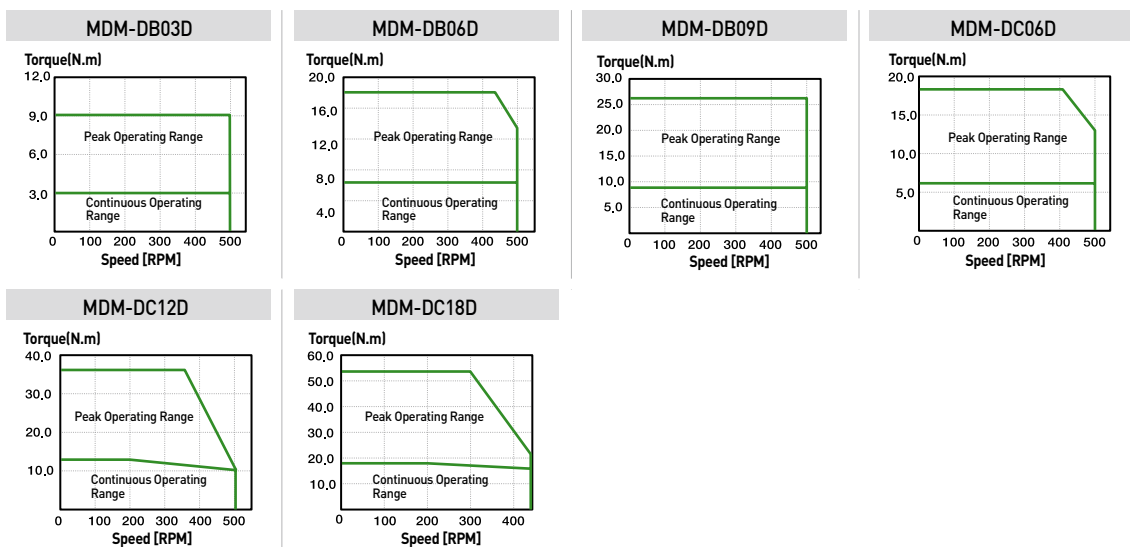

Motor Designation		MDM-DD□□D□□H-I			MDM-DE□□D□□H-I		MDM-DF□□G□□H-I		MDM-DG□□G□□H-I
		12	22	34	40	60	A1	A6	C3
Applicable Drive		L7□A004□	L7□A008□	L7□A010□	L7□A010□	L7□A020□	L7□A020□	L7□A035□	L7□A020□
Ext. Diameter of Motor	mm	Ø230			Ø290		Ø360		Ø380
Rated Output	W	251	461	712	838	1,257	1,728	2,513	1,728
Rated Torque	N-m	12	22	34	40	60	110	160	330
Max Torque	N-m	36	66	102	120	180	330	480	1,000
Rated Current	Arms	2.58	3.33	5.72	5.3	8.33	9.48	14.6	12.0
Max Current	Arms	7.74	9.99	17.16	15.9	24.99	28.44	43.8	36.0
Rated Speed	rpm	200			200		150		50
Max Speed	rpm	500	400	400	300	300	250	250	100
Torque Constant	N-m/Arms	4.8	6.81	6.13	7.77	7.42	11.95	11.29	28.59
Inertia Moment	kg-m ² X10 ⁻⁴	94.70	141.10	190.70	427.2	587.9	2507.0	3457.0	6449.0
Allowable Load Inertia Ratio		15 times of motor inertia			3 times of motor inertia				
Power Rate	kW/S	15.2	34.3	60.6	37.5	61.2	48.3	74.1	169.1
Positioning Accuracy	arc-sec	±30							
Positioning Repeatability	arc-sec	±1.3							
Axial run-out	mm	0.015							
Radial run-out	mm	0.03							
Allowable Thrust Load	N	4,000			11,000		15,000		21,000
Allowable Moment Load	N-m	93			250		350		450
Encoder Type		20-bit single turn serial encoder (Biss/Absolute)							
Weight(Approx.)	kg	14.5	18.8	23.2	28.0	34.5	53.5	69.0	162
Working Environment	Ambient Temp	Ambient temperature: 0~40[°C] / storage: -20~60[°C]							
	Ambient Humidity	20~80[%] RH(Noncondensing)							
	Atmosphere	Avoid direct sunlight and corrosive / flammable gas.							

Speed-Torque Characteristics

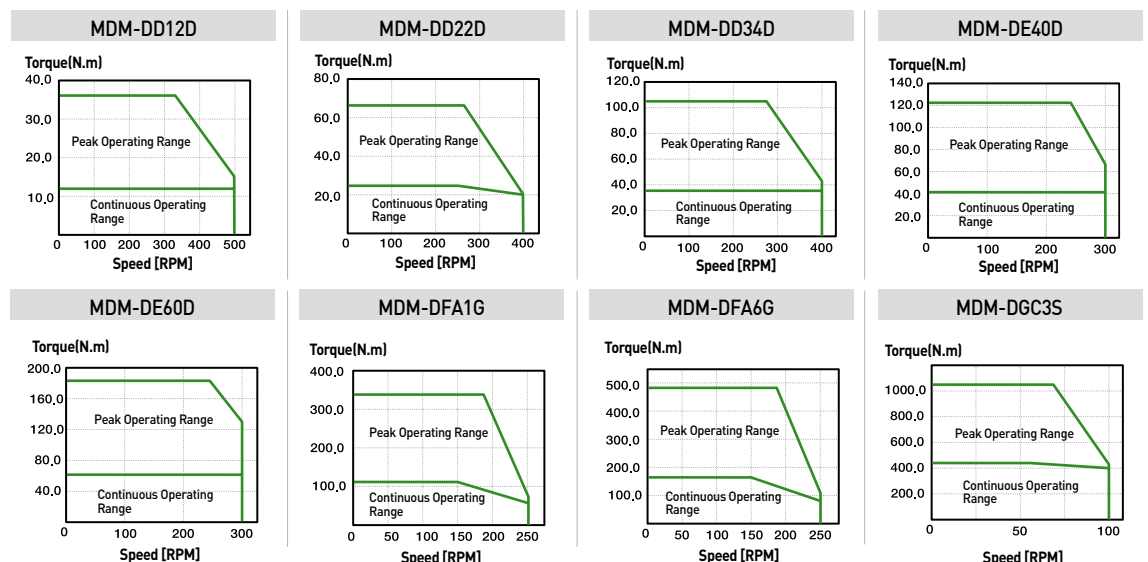

Servo Motor

MDM-DB03D, MDM-DB06D, MDM-DB09D

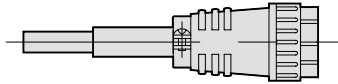

NJC-24-4-PM

Contents		Pin No.
LEAD WIRE	U	1
	V	2
	W	3
Ground		4

[Power Connector Pin Table]

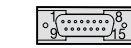
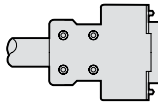

D-Sub Connector (15pin)

D.D SERVO ENCODER CABLE			
NO.	Encoder Signal	NO.	Encoder Signal
1	MA	9	+5V
2	SLO	10	-
3	-	11	-
4	OV	12	-
5	SHIELD	13	-
6	MA	14	-
7	SLO	15	-
8	-		

[Encoder Connector Pin Table]

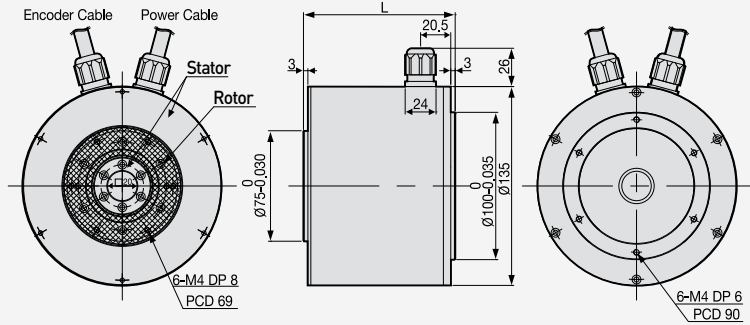

Model	External Dimensions(mm)	Weight (kg)
	L	
MDM-DB03D	78	6.3
MDM-DB06D	100	7.2
MDM-DB09D	124	9.2

MDM-DC06D, MDM-DC12D, MDM-DC18D

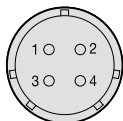
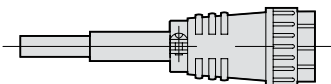

NJC-24-4-PM

Contents		Pin No.
LEAD WIRE	U	1
	V	2
	W	3
Ground		4

[Power Connector Pin Table]

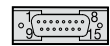
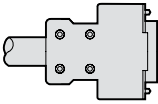

D-Sub Connector (15pin)

D.D SERVO ENCODER CABLE			
NO.	Encoder Signal	NO.	Encoder Signal
1	MA	9	+5V
2	SLO	10	-
3	-	11	-
4	OV	12	-
5	SHIELD	13	-
6	MA	14	-
7	SLO	15	-
8	-		

[Encoder Connector Pin Table]

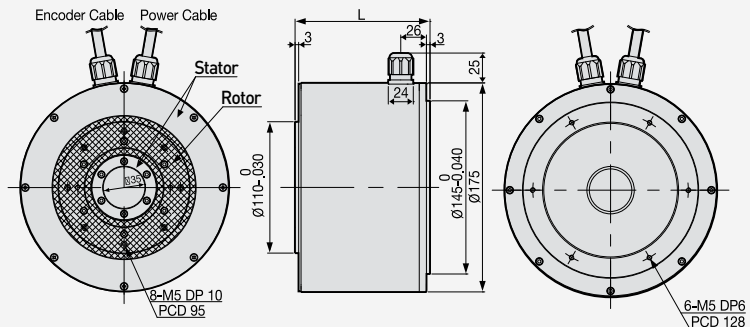

Model	External Dimensions(mm)	Weight (kg)
	L	
MDM-DC06D	77	8.7
MDM-DC12D	95	10.6
MDM-DC18D	113	12.6

MDM-DFA1G, MDM-DFA6G

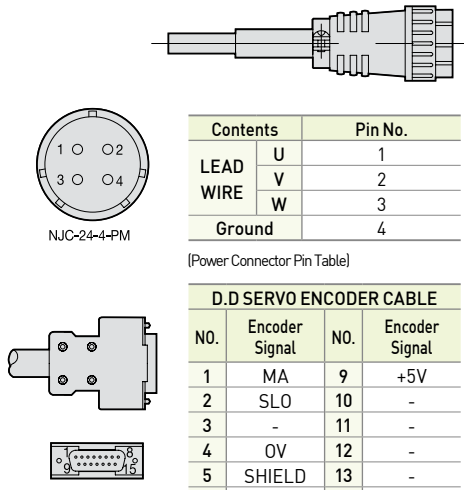

NJC-24-4-PM

Contents	Pin No.	
LEAD WIRE	U	1
	V	2
	W	3
Ground		4

[Power Connector Pin Table]

D.D SERVO ENCODER CABLE			
NO.	Encoder Signal	NO.	Encoder Signal
1	MA	9	+5V
2	SLO	10	-
3	-	11	-
4	OV	12	-
5	SHIELD	13	-
6	MA	14	-
7	SLO	15	-
8	-		

[Encoder Connector Pin Table]

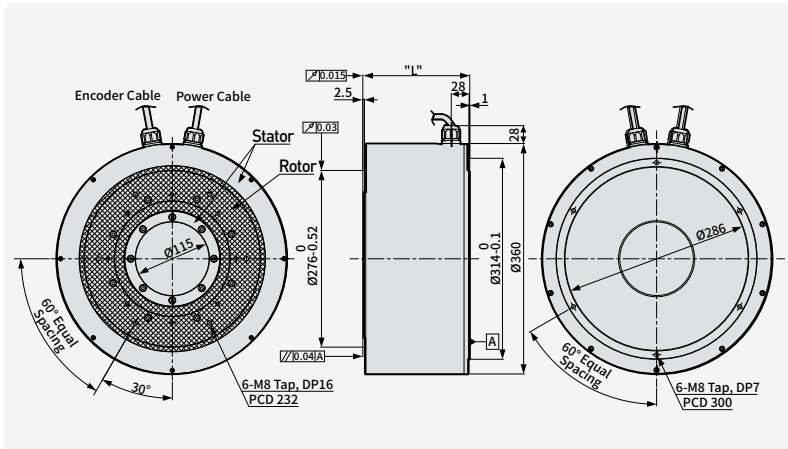

Encoder Cable Power Cable Stator Rotor
 60° Equal Spacing 30°
 6-M8 Tap, DP16 PCD 232
 6-M8 Tap, DP7 PCD 300

Model	External Dimensions(mm)		Weight (kg)
	L		
MDM-DFA1G	131		54
MDM-DFA6G	167		70.3

MDM-DGC3SNOH

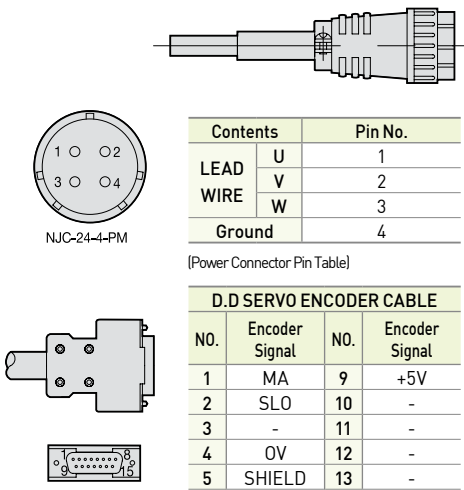

NJC-24-4-PM

Contents	Pin No.	
LEAD WIRE	U	1
	V	2
	W	3
Ground		4

[Power Connector Pin Table]

D.D SERVO ENCODER CABLE			
NO.	Encoder Signal	NO.	Encoder Signal
1	MA	9	+5V
2	SLO	10	-
3	-	11	-
4	OV	12	-
5	SHIELD	13	-
6	MA	14	-
7	SLO	15	-
8	-		

[Encoder Connector Pin Table]

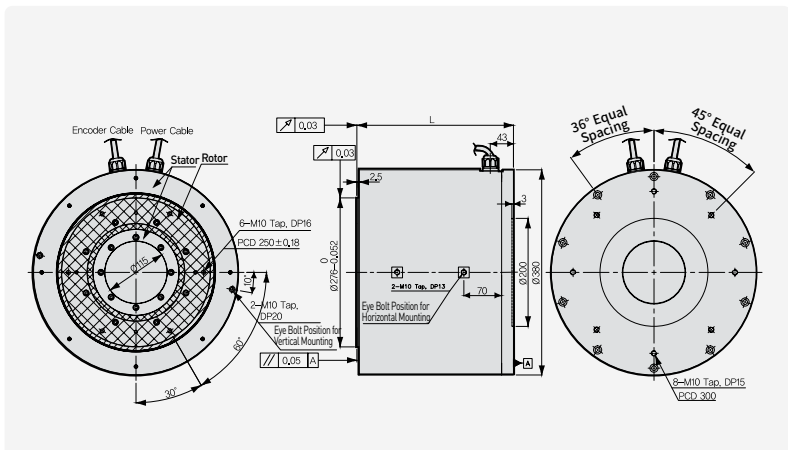

Encoder Cable Power Cable Stator Rotor
 36° Equal Spacing 45° Equal Spacing
 6-M10 Tap, DP16 PCD 250±0.18
 2-M10 Tap, DP20 Eye Bolt Position for Vertical Mounting
 2-M10 Tap, DP13 Eye Bolt Position for Horizontal Mounting
 3-M10 Tap, DP15 PCD 300

Model	External Dimensions(mm)		Weight (kg)
	L		
MDM-DGC3SNOH	290		162

Troubleshooting

If an overcurrent alarm occurs

- Please check if the drive output and the encoder are wired properly.
- Please check for equipment collision or restraint.

High performance

- Please inspect the input voltage and load condition.
- Please check if the drive output and the encoder are wired properly.
- Please check for equipment collision or restraint.



DD Motor Flange Type Designation

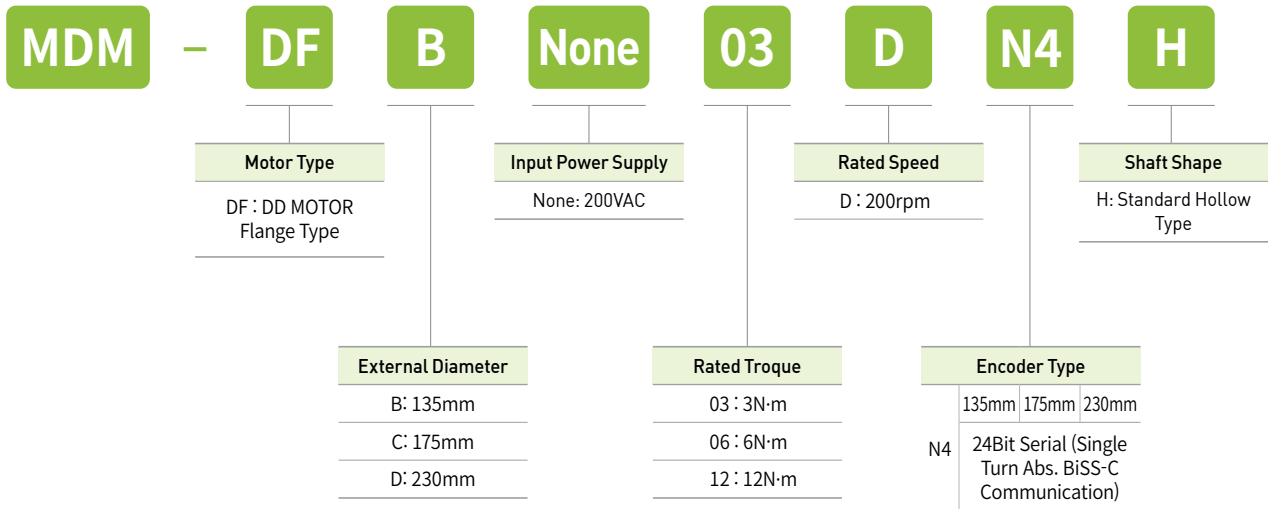

Using the Own Technologies to Produce Motors, Drives and Encoders Domestically

Optimized for Low-speed, High-torque and High-precision Operation

- Providing Power connection for the connection of DC-Link Terminal
- Compact Size and Easy Wiring (Compared with 3 phase AC Reactor)
- Providing Connection for DC Input (PI, N)

Reduced Cogging Torque and Optimized Torque Design

- Optimal ratio of the permanent magnet and coil / slot selected through electromagnetic analysis
- Using multiple permanent magnets to reduce torque ripple and to maximize torque
- Using a permanent magnet of high-energy rare earth elements (Nd-Fe-B)

High-performance Optical Encoder with BiSS Protocol

- DD MOTOR Flange Type
Resolution : 16, 777, 216 [Pulse/rev] [24Bit, Single turn]

Compatible with Our AC Servo Drive (3-phase 200V AC)

- L7 Series(200VAC), iX7NH Series(200VAC)
Both standard I/O type with serial communication and network (EtherCAT) type are applicable

Direct Drive Structure

- No backlash impact
- High-precision operation and shortened installation time
- Smooth rotary motion
- Noise reduction

Hollow Structure Enables Efficient Wiring & Piping

Diverse Product Range

- Rated output: 63W, 126W, 251W
- Rated torque: 3N·m, 6N·m, 12N·m
(Instantaneous maximum torque is 3x)
- Rated speed: 200RPM
- Frame diameter: 135mm, 175mm, 230mm

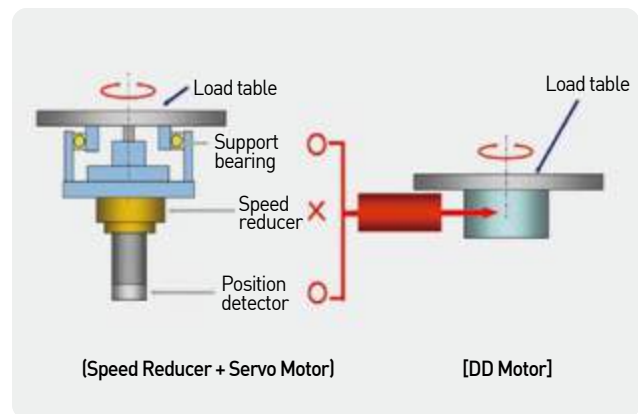
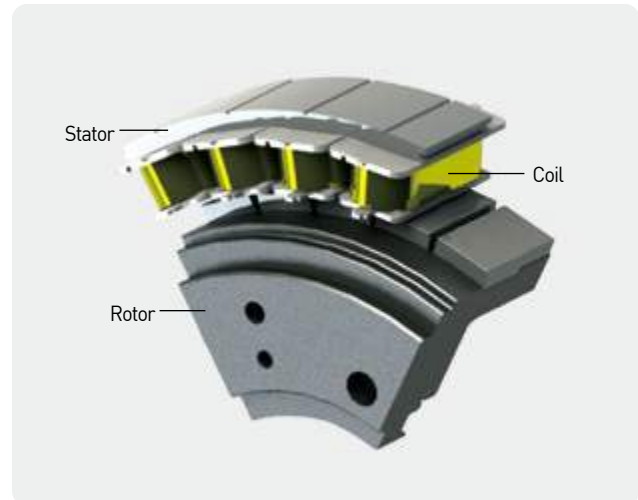



DD Motor Specifications

Ratings and Specifications

- Insulation Class : Class B
- Ingress Protection Code : IP40
- Cooling : Fully-enclosed, self-cooling
- Vibration Class : V15
- Insulation Resistance : 500 VDC, 10MΩ or higher
- Withstand Voltage : 1500 VAC, 1 min
- Operating Voltage : 200 VAC
- Operating Temperature : 0° to 40°C
- Storage Temperature : -10° to 60°C
- Relative Humidity : 20% to 80% noncondensing
- Installation Environment : Keep away from hazardous substances such as corrosive or flammable gas, cutting fluid, metal dust or oil. Keep away from direct sunlight.

Line-up Table

		Rated Torque[N·m]	3	6	12
		Maximum Torque[N·m]	9	18	36
Rated Speed 200[rpm]	Maximum Speed 500[rpm]	Ø135	DFB03D 		
		Ø175		DFC06D 	
		Ø230			DFD12D 

Drive Combination Table

MDM Serial Type

Rated Speed (RPM)	Maximum Speed (RPM)	External Diameter of Motor(Ø)	Motor	Drive	Power Cables	Encoders Cable (Serial)	Standard Encoders
200	500	135	DFB03D	L7□A001□	APCS-P□□□YS1	APCS-E□□□ZS1	24Bit Serial (Single Turn Abs. BiSS-C communication)
				iX7□A001□	APCS-P□□□YSX1		
		175	DFC06D	L7□A002□	APCS-P□□□YS1		
				iX7□A002□	APCS-P□□□YSX1		
		230	DFD12D	L7□A004□	APCS-P□□□YS1		
				iX7□A004□	APCS-P□□□YSX1		

Motor Shape



Servo Motor

Motor Designation		MDM-DFB03DN4H	MDM-DFC06DN4H	MDM-DFD12DN4H
		03	06	12
Applicable Drive		L7□A002□	L7□A002□	L7□A004□
Flange Size	mm	135	175	230
Rated Output	W	63	126	251
Rated Torque	N-m	3	6	12
Max Torque	N-m	9	18	36
Rated Current	Arms	1.43	1.50	2.60
Max Current	Arms	4.29	4.50	7.80
Rated Speed	rpm	200	200	200
Max Speed	rpm	500	500	500
Constant of Torque	N-m/Arms	2.22	4.18	4.8
Inertia	kg·m ² X10 ⁻⁴	10.30	58.05	110.00
Allowable Load Inertia Ratio		30 times of motor inertia		15 times of motor inertia
Power Rate	kW/S	8.7	6.21	13.1
Positioning Accuracy	arc-sec	±30	±30	±30
Positioning Repeatability	arc-sec	1.3	1.3	1.3
Axial run-out	mm	0.015	0.015	0.015
Radial run-out	mm	0.03	0.03	0.03
Allowable Thrust Load	N	1500	3300	3600
Max. Instantaneous	N-m	40	70	80
Encoder Type		24-bit single turn serial encoder (BiSS/Absolute)		
Weight(Approx.)	kg	3.8	6.9	12.3
Working Environment	Ambient Temp	Operating Temperature : 0° to 40°C / Storage Temperature : -20° to 60°C		
	Ambient Humidity	20% to 80% noncondensing		
	Atmosphere	Keep out of direct sunlight, corrosive substances or flammable gas.		

Speed-Torque Characteristics

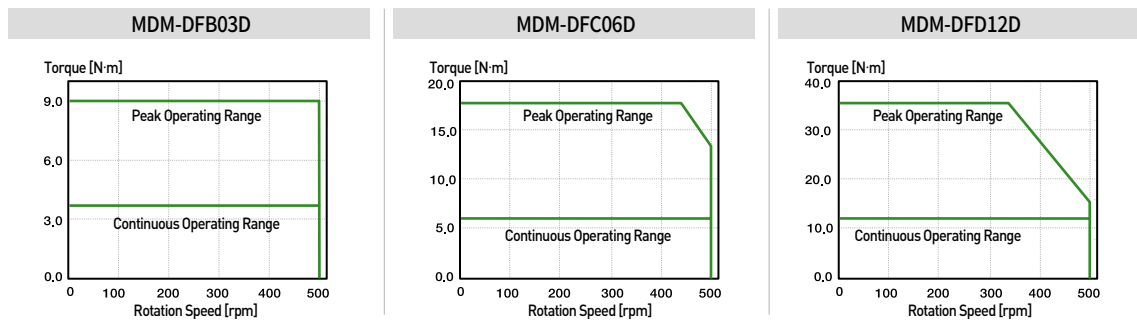

MDM-DFB03D



JN1AS04MK1(JAE)

Contents		Pin No.	
LEAD	U	1	
	V	2	
WIRE	W	3	
	FG	FG	4

[Power Connector Pin Table]

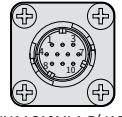

JN1AS10ML1-R(JAE)

D.D SERVO ENCODER CABLE			
NO.	Encoder Signal	NO.	Encoder Signal
1	MA	6	MA
2	SLO	7	SLO
3	-	8	-
4	OV	9	+5V
5	SHIELD	10	-

[Encoder Connector Pin Table]

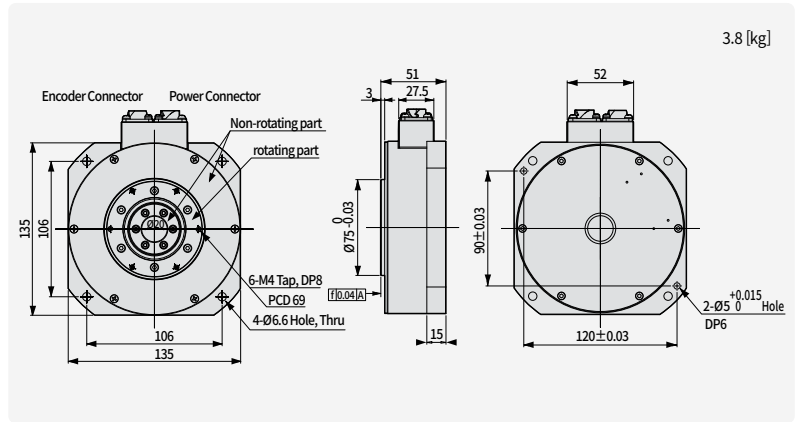

MDM-DFC06D



JN1AS04MK1(JAE)

Contents		Pin No.	
LEAD	U	1	
	V	2	
WIRE	W	3	
	FG	FG	4

[Power Connector Pin Table]

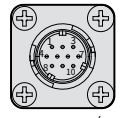

JN1AS10ML1-R(JAE)

D.D SERVO ENCODER CABLE			
NO.	Encoder Signal	NO.	Encoder Signal
1	MA	6	MA
2	SLO	7	SLO
3	-	8	-
4	OV	9	+5V
5	SHIELD	10	-

[Encoder Connector Pin Table]

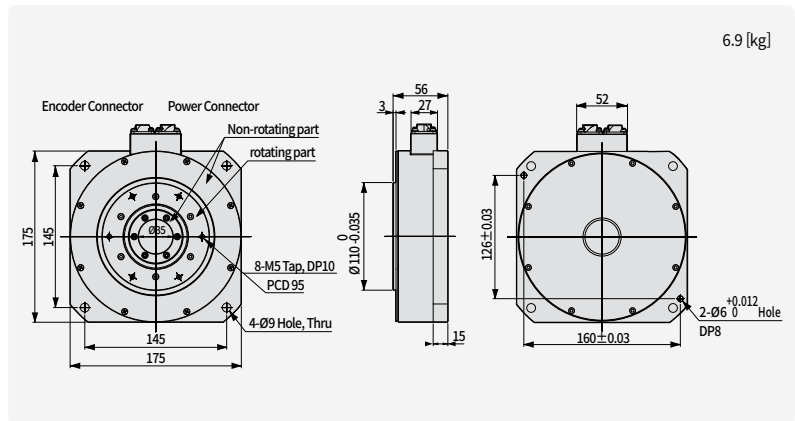

MDM-DFD12D



JN1AS04MK1(JAE)

Contents		Pin No.	
LEAD	U	1	
	V	2	
WIRE	W	3	
	FG	FG	4

[Power Connector Pin Table]

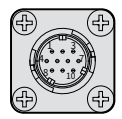

JN1AS10ML1-R(JAE)

D.D SERVO ENCODER CABLE			
NO.	Encoder Signal	NO.	Encoder Signal
1	MA	6	MA
2	SLO	7	SLO
3	-	8	-
4	OV	9	+5V
5	SHIELD	10	-

[Encoder Connector Pin Table]

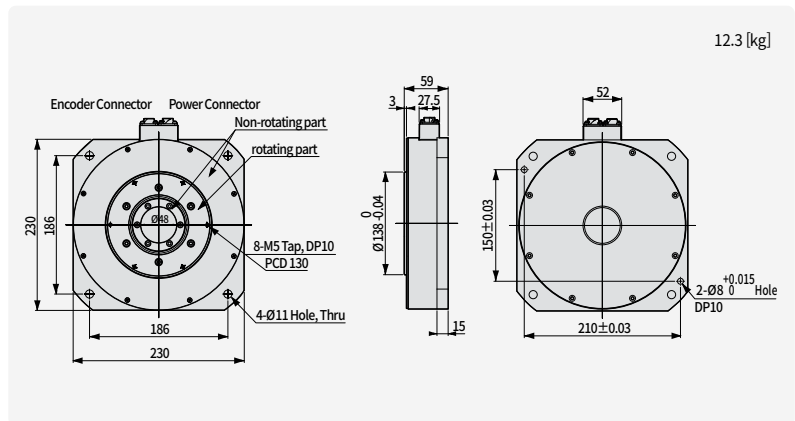

Troubleshooting

If an overcurrent alarm occurs

- Please check if the drive output and the encoder are wired properly.
- Please check for equipment collision or restraint.

High performance

- Please inspect the input voltage and load condition.
- Please check if the drive output and the encoder are wired properly.
- Please check for equipment collision or restraint.

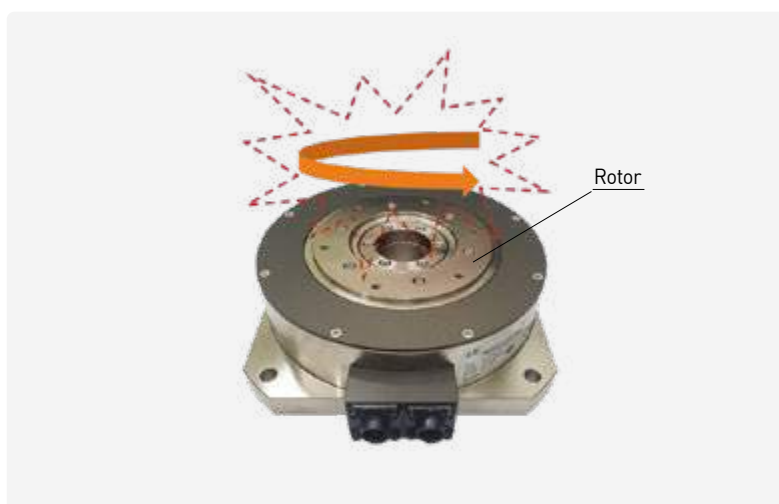

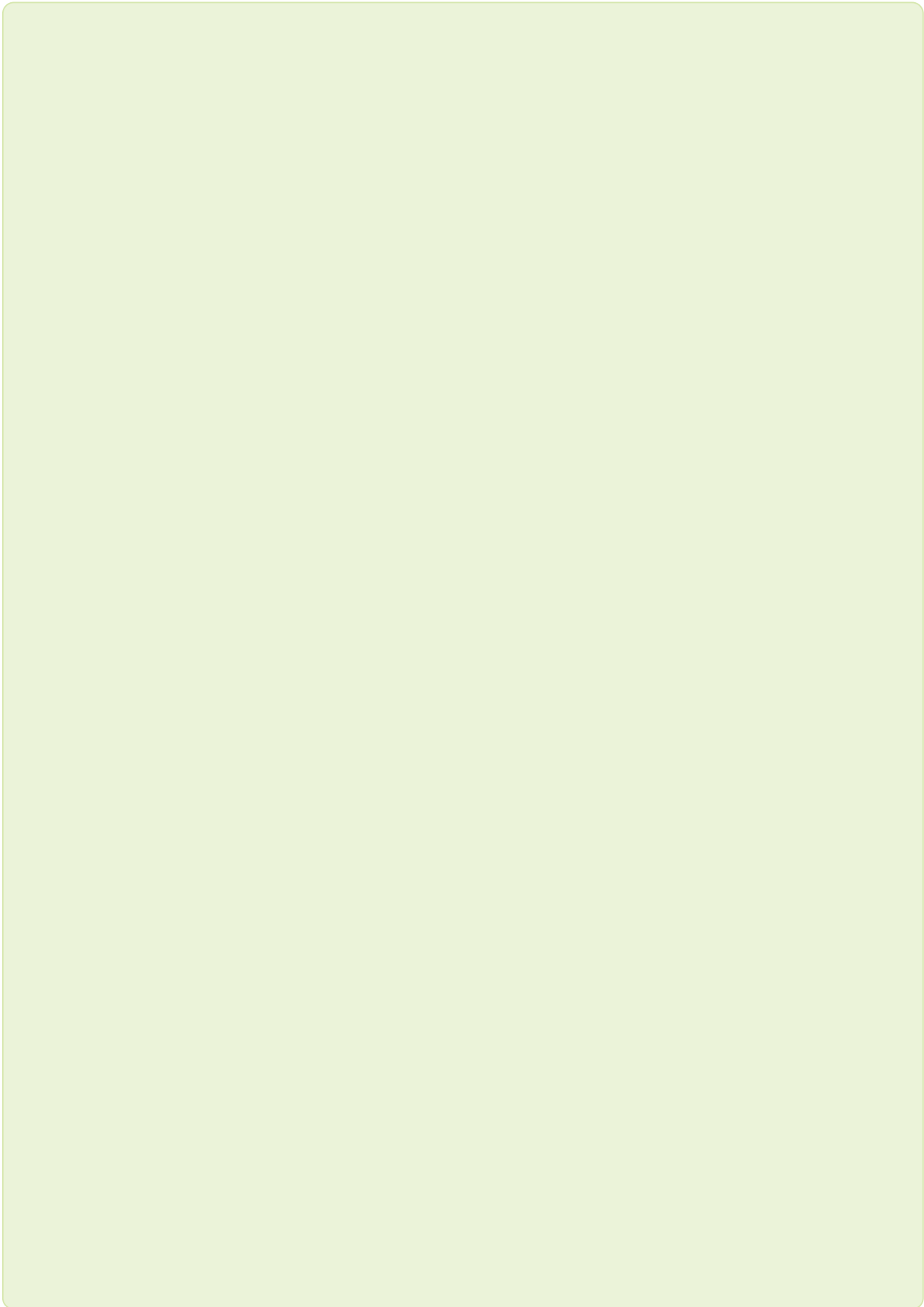



A ○

B ○

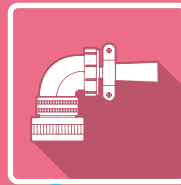
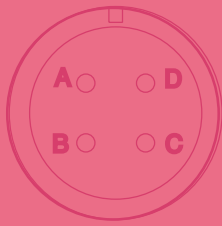

Options and Accessories

Contents

Designation	142
Signal Cable	142
Power Cable	146
E Series Signal Cables	157
E Series Power Cables	159
DD Motor Signal Cables	166
DD Motor Power Cables	167
DD Motor Flange Type Signal Cables	168
DD Motor Flange Type Power Cables	169
PHOX Series Cables	170
Connector Pin Map	173
Option Connector	174
200V Braking Resistor	175
400V Braking Resistor	176
Noise Filter	177

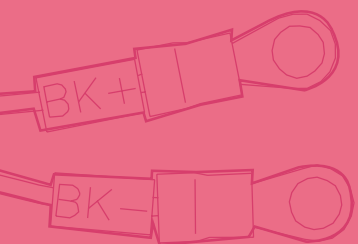

Designation

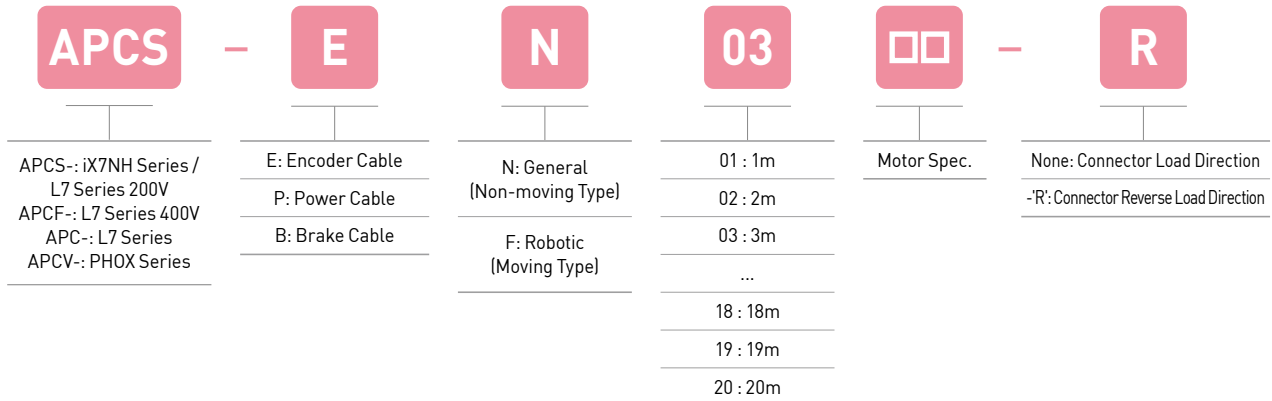

Note) Unstable ground connections to power and encoder options cables may result in AL due to noise

Note) 01- 20: 1m to 20m Cable Length Provided, Cable Length Selection in 1m Increments

Signal Cables

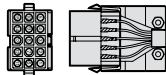
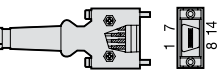
Type	Product Type	Model Name ^{Note1)}	Applicable Drive ^{Note2)}	Applicable Motor	Specifications																																																																								
For Signal	H Series Cable (Small Capacity)	APCS-E □□□AS	L7SA□□□A L7NHA□□□U L7PA□□□U L7NHF□□□U	All Models of HB Series	<div style="display: flex; justify-content: space-around;"> <div style="text-align: center;"> <p>Motor Side Connector</p>  <p>[Motor Side Connector]</p> </div> <div style="text-align: center;"> <p>Drive Side Connector(CN2)</p>  <p>[Driver Side Connector]</p> </div> </div> <table border="1" style="width: 100%; border-collapse: collapse; text-align: center;"> <thead> <tr> <th>PIN No.</th> <th>Encoder Signal</th> <th>PIN No.</th> <th>Encoder Signal</th> <th>PIN No.</th> <th>Encoder Signal</th> <th>PIN No.</th> <th>Encoder Signal</th> </tr> </thead> <tbody> <tr> <td>A</td> <td>A</td> <td>M</td> <td>V</td> <td>1</td> <td>W</td> <td>8</td> <td>Z̄</td> </tr> <tr> <td>B</td> <td>Ā</td> <td>N</td> <td>V̄</td> <td>2</td> <td>W̄</td> <td>9</td> <td>Z</td> </tr> <tr> <td>C</td> <td>B</td> <td>P</td> <td>W</td> <td>3</td> <td>V</td> <td>10</td> <td>B̄</td> </tr> <tr> <td>D</td> <td>B̄</td> <td>R</td> <td>W̄</td> <td>4</td> <td>V̄</td> <td>11</td> <td>B</td> </tr> <tr> <td>E</td> <td>Z</td> <td>H</td> <td>+5V</td> <td>5</td> <td>U</td> <td>12</td> <td>Ā</td> </tr> <tr> <td>F</td> <td>Z̄</td> <td>G</td> <td>0V</td> <td>6</td> <td>Ū</td> <td>13</td> <td>A</td> </tr> <tr> <td>K</td> <td>U</td> <td>J</td> <td>SHIELD</td> <td>7</td> <td>OV</td> <td>14</td> <td>+5V</td> </tr> <tr> <td>L</td> <td>Ū</td> <td></td> <td></td> <td colspan="2">PLATE</td> <td colspan="2">SHIELD</td> </tr> </tbody> </table> <p>1. Motor Side Connector</p> <ul style="list-style-type: none"> • Cap Spec. (15 Position): 172163-1(AMP) • Socket Spec. : 170361-1(AMP) <p>2. Driver Side Connector(CN2)</p> <ul style="list-style-type: none"> • Case Spec. : 10314-52A0-008(3M) or SM-14J(Suntone) • Connector Spec. : 10114-3000VE(3M) or SM-14J(Suntone) <p>3. Cable Spec. : 7P×0.25Q or 7P×AWG24</p>	PIN No.	Encoder Signal	PIN No.	Encoder Signal	PIN No.	Encoder Signal	PIN No.	Encoder Signal	A	A	M	V	1	W	8	Z̄	B	Ā	N	V̄	2	W̄	9	Z	C	B	P	W	3	V	10	B̄	D	B̄	R	W̄	4	V̄	11	B	E	Z	H	+5V	5	U	12	Ā	F	Z̄	G	0V	6	Ū	13	A	K	U	J	SHIELD	7	OV	14	+5V	L	Ū			PLATE		SHIELD	
PIN No.	Encoder Signal	PIN No.	Encoder Signal	PIN No.	Encoder Signal	PIN No.	Encoder Signal																																																																						
A	A	M	V	1	W	8	Z̄																																																																						
B	Ā	N	V̄	2	W̄	9	Z																																																																						
C	B	P	W	3	V	10	B̄																																																																						
D	B̄	R	W̄	4	V̄	11	B																																																																						
E	Z	H	+5V	5	U	12	Ā																																																																						
F	Z̄	G	0V	6	Ū	13	A																																																																						
K	U	J	SHIELD	7	OV	14	+5V																																																																						
L	Ū			PLATE		SHIELD																																																																							

Note1) The three blank squares in model names indicate the type and length of cables. And the designation is as below.

Cable Length(m)	1	2	3	...	18	19	20
General Cable	N01	N02	N03	...	N18	N19	N20
Robotic Cable	F01	F02	F03	...	F18	F19	F20

Note2) The three blank squares in model names indicate drive capacity. For details regarding the designation, please refer to pages 16 / 22 / 28 / 38 / 44 / 54 / 58 / 66 / 72page

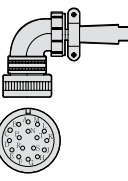
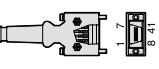
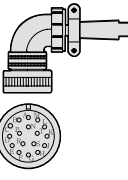
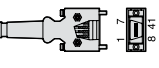
Type	Product Type	Model Name <small>Note1</small>	Applicable Drive <small>Note2</small>	Applicable Motor	Specifications																																																																																
For Signal	H Series Cable (Middle Capacity)	APCS-E□□□BS	L7SA□□□A L7NHA□□□U L7PA□□□U L7NHF□□□U	All Models of HE Series	<div style="display: flex; justify-content: space-around;"> <div style="text-align: center;">  <p>Motor Side Connector</p> </div> <div style="text-align: center;">  <p>Drive Side Connector(CN2)</p> </div> </div> <table border="1" style="width: 100%; border-collapse: collapse; text-align: center;"> <thead> <tr> <th>PIN No.</th><th>Encoder Signal</th><th>PIN No.</th><th>Encoder Signal</th><th>PIN No.</th><th>Encoder Signal</th><th>PIN번호</th><th>Encoder Signal</th></tr> </thead> <tbody> <tr><td>A</td><td>A</td><td>M</td><td>V</td><td>1</td><td>W</td><td>8</td><td>Z̄</td></tr> <tr><td>B</td><td>Ā</td><td>N</td><td>V̄</td><td>2</td><td>W̄</td><td>9</td><td>Z</td></tr> <tr><td>C</td><td>B</td><td>P</td><td>W</td><td>3</td><td>V</td><td>10</td><td>B̄</td></tr> <tr><td>D</td><td>B̄</td><td>R</td><td>W̄</td><td>4</td><td>V̄</td><td>11</td><td>B</td></tr> <tr><td>E</td><td>Z</td><td>H</td><td>+5V</td><td>5</td><td>U</td><td>12</td><td>Ā</td></tr> <tr><td>F</td><td>Z̄</td><td>G</td><td>0V</td><td>6</td><td>Ū</td><td>13</td><td>A</td></tr> <tr><td>K</td><td>U</td><td>J</td><td>SHIELD</td><td>7</td><td>OV</td><td>14</td><td>+5V</td></tr> <tr><td>L</td><td>Ū</td><td></td><td></td><td></td><td></td><td></td><td></td></tr> <tr><td></td><td></td><td></td><td></td><td></td><td>PLATE</td><td></td><td>SHIELD</td></tr> </tbody> </table> <p>[Motor Side Connector] [Driver Side Connector]</p> <ol style="list-style-type: none"> Motor Side Connector(MS : Military Standard) <ul style="list-style-type: none"> • Plug Spec.: MS3108A20-29S Driver Side Connector(CN2) <ul style="list-style-type: none"> • Case Spec.: 10314-52A0-008(3M) or SM-14J(Suntone) • Connector Spec.: 10114-3000VE(3M) or SM-14J(Suntone) Cable Spec. : 7P×0.25Q or 7P×AWG24 	PIN No.	Encoder Signal	PIN No.	Encoder Signal	PIN No.	Encoder Signal	PIN번호	Encoder Signal	A	A	M	V	1	W	8	Z̄	B	Ā	N	V̄	2	W̄	9	Z	C	B	P	W	3	V	10	B̄	D	B̄	R	W̄	4	V̄	11	B	E	Z	H	+5V	5	U	12	Ā	F	Z̄	G	0V	6	Ū	13	A	K	U	J	SHIELD	7	OV	14	+5V	L	Ū												PLATE		SHIELD
PIN No.	Encoder Signal	PIN No.	Encoder Signal	PIN No.	Encoder Signal	PIN번호	Encoder Signal																																																																														
A	A	M	V	1	W	8	Z̄																																																																														
B	Ā	N	V̄	2	W̄	9	Z																																																																														
C	B	P	W	3	V	10	B̄																																																																														
D	B̄	R	W̄	4	V̄	11	B																																																																														
E	Z	H	+5V	5	U	12	Ā																																																																														
F	Z̄	G	0V	6	Ū	13	A																																																																														
K	U	J	SHIELD	7	OV	14	+5V																																																																														
L	Ū																																																																																				
					PLATE		SHIELD																																																																														
For Signal	F Series Motor S-turn Encoder Cable (Middle Capacity)	APCS-E□□□DS	L7S□□□B L7NH□□□□U L7PA□□□U L7NHF□□□U L7CA□□□U	All Models of FE/FEP FF/FFP FG/FGP Series	<div style="display: flex; justify-content: space-around;"> <div style="text-align: center;">  <p>Motor Side Connector</p> </div> <div style="text-align: center;">  <p>Drive Side Connector(CN2)</p> </div> </div> <table border="1" style="width: 100%; border-collapse: collapse; text-align: center;"> <thead> <tr> <th>PIN No.</th><th>Encoder Signal</th><th>PIN No.</th><th>Encoder Signal</th><th>PIN No.</th><th>Encoder Signal</th><th>PIN No.</th><th>Encoder Signal</th></tr> </thead> <tbody> <tr><td>A</td><td>MA</td><td>M</td><td>-</td><td>1</td><td>-</td><td>8</td><td>-</td></tr> <tr><td>B</td><td>MĀ</td><td>N</td><td>-</td><td>2</td><td>-</td><td>9</td><td>-</td></tr> <tr><td>C</td><td>SLO</td><td>P</td><td>-</td><td>3</td><td>MA</td><td>10</td><td>-</td></tr> <tr><td>D</td><td>SLŌ</td><td>R</td><td>-</td><td>4</td><td>MĀ</td><td>11</td><td>-</td></tr> <tr><td>E</td><td>-</td><td>H</td><td>+5V</td><td>5</td><td>SLO</td><td>12</td><td>-</td></tr> <tr><td>F</td><td>-</td><td>G</td><td>0V</td><td>6</td><td>SLŌ</td><td>13</td><td>-</td></tr> <tr><td>K</td><td>-</td><td>J</td><td>SHIELD</td><td>7</td><td>OV</td><td>14</td><td>+5V</td></tr> <tr><td>L</td><td>-</td><td></td><td></td><td></td><td></td><td></td><td></td></tr> <tr><td></td><td></td><td></td><td></td><td></td><td>PLATE</td><td></td><td>SHIELD</td></tr> </tbody> </table> <p>[Motor Side Connector] [Driver Side Connector]</p> <ol style="list-style-type: none"> Motor Side Connector(MS : Military Standard) <ul style="list-style-type: none"> • Plug Spec.: MS3108A20-29S Driver Side Connector(CN2) <ul style="list-style-type: none"> • Case Spec.: 10314-52A0-008(3M) or SM-14J(Suntone) • Connector Spec.: 10114-3000VE(3M) or SM-14J(Suntone) Cable Spec. : 3P×0.25Q or 3P×24AWG 	PIN No.	Encoder Signal	PIN No.	Encoder Signal	PIN No.	Encoder Signal	PIN No.	Encoder Signal	A	MA	M	-	1	-	8	-	B	MĀ	N	-	2	-	9	-	C	SLO	P	-	3	MA	10	-	D	SLŌ	R	-	4	MĀ	11	-	E	-	H	+5V	5	SLO	12	-	F	-	G	0V	6	SLŌ	13	-	K	-	J	SHIELD	7	OV	14	+5V	L	-												PLATE		SHIELD
PIN No.	Encoder Signal	PIN No.	Encoder Signal	PIN No.	Encoder Signal	PIN No.	Encoder Signal																																																																														
A	MA	M	-	1	-	8	-																																																																														
B	MĀ	N	-	2	-	9	-																																																																														
C	SLO	P	-	3	MA	10	-																																																																														
D	SLŌ	R	-	4	MĀ	11	-																																																																														
E	-	H	+5V	5	SLO	12	-																																																																														
F	-	G	0V	6	SLŌ	13	-																																																																														
K	-	J	SHIELD	7	OV	14	+5V																																																																														
L	-																																																																																				
					PLATE		SHIELD																																																																														

Note1) The three blank squares in model names indicate the type and length of cables. And the designation is as below.

Cable Length(m)	1	2	3	...	18	19	20
General Cable	N01	N02	N03	...	N18	N19	N20
Robotic Cable	F01	F02	F03	...	F18	F19	F20

Note2) The three blank squares in model names indicate drive capacity. For details regarding the designation, please refer to pages 16 / 22 / 28 / 38 / 44 / 54 / 58 / 66 / 72page

Signal Cable

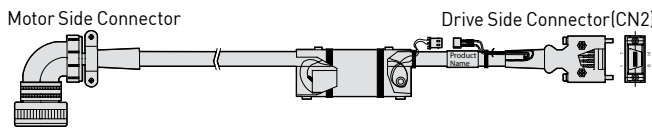
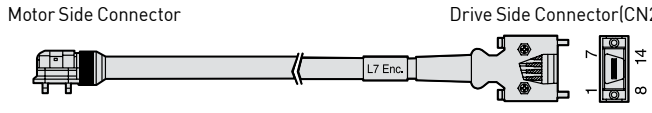
Type	Product Type	Model Name	Applicable Drive	Applicable Motor	Specifications																																																																														
For Signal	F Series Motor M-turn Encoder Cable (Middle Capacity)	<p>Note1) APCS-E□□□DS1</p>	L7S□□□B L7NH□□□□U L7PA□□□□U L7NH□□□□U	All Models of FE/FEP FF/FFP FG/FGP SERIES Series	 <p>Motor Side Connector</p> <p>Drive Side Connector(CN2)</p> <table border="1"> <thead> <tr> <th>PIN No</th> <th>Encoder Signal</th> <th>PIN No</th> <th>Encoder Signal</th> </tr> </thead> <tbody> <tr><td>A</td><td>MA</td><td>M</td><td>-</td></tr> <tr><td>B</td><td>MA</td><td>N</td><td>-</td></tr> <tr><td>C</td><td>SLO</td><td>P</td><td>-</td></tr> <tr><td>D</td><td>SLO</td><td>R</td><td>-</td></tr> <tr><td>E</td><td>VQD_B</td><td>H</td><td>+5V</td></tr> <tr><td>F</td><td>GND_B</td><td>G</td><td>OV</td></tr> <tr><td>K</td><td>-</td><td>J</td><td>SHELD</td></tr> <tr><td>L</td><td>-</td><td>-</td><td>-</td></tr> </tbody> </table> <p>MS3108B20-29S</p> <table border="1"> <thead> <tr> <th>PIN No</th> <th>Encoder Signal</th> <th>PIN No</th> <th>Encoder Signal</th> </tr> </thead> <tbody> <tr><td>1</td><td>-</td><td>8</td><td>-</td></tr> <tr><td>2</td><td>-</td><td>9</td><td>-</td></tr> <tr><td>3</td><td>MA</td><td>10</td><td>-</td></tr> <tr><td>4</td><td>MA</td><td>11</td><td>-</td></tr> <tr><td>5</td><td>SLO</td><td>12</td><td>-</td></tr> <tr><td>6</td><td>SLO</td><td>13</td><td>-</td></tr> <tr><td>7</td><td>OV</td><td>14</td><td>+5V</td></tr> <tr><td colspan="2">PLATE</td><td colspan="2">SHIELD</td></tr> </tbody> </table> <p>(Motor Side Connector) (Drive Side Connector)</p> <table border="1"> <thead> <tr> <th>PIN No</th> <th>Encoder Signal</th> </tr> </thead> <tbody> <tr><td>1</td><td>-</td></tr> <tr><td>2</td><td>-</td></tr> </tbody> </table> <p>(Battery Connector)</p> <p>1. Motor Side Connector (MS: Military Standard) • Plug Spec.: MS3108A20-29S</p> <p>2. Drive Side Connector (CN2) • Case Spec.: 10314-52A0-008(3M) or SM-14J(Suntone) • Connector Spec.: 10114-3000VE(3M) or SM-14J(Suntone) • Cable Spec.: 4P×0.25SQ or 4P×24AWG • BATTERY CONNECTOR Spec.: 5267-02A(MOLEX)</p>	PIN No	Encoder Signal	PIN No	Encoder Signal	A	MA	M	-	B	MA	N	-	C	SLO	P	-	D	SLO	R	-	E	VQD_B	H	+5V	F	GND_B	G	OV	K	-	J	SHELD	L	-	-	-	PIN No	Encoder Signal	PIN No	Encoder Signal	1	-	8	-	2	-	9	-	3	MA	10	-	4	MA	11	-	5	SLO	12	-	6	SLO	13	-	7	OV	14	+5V	PLATE		SHIELD		PIN No	Encoder Signal	1	-	2	-
					PIN No	Encoder Signal	PIN No	Encoder Signal																																																																											
A	MA	M	-																																																																																
B	MA	N	-																																																																																
C	SLO	P	-																																																																																
D	SLO	R	-																																																																																
E	VQD_B	H	+5V																																																																																
F	GND_B	G	OV																																																																																
K	-	J	SHELD																																																																																
L	-	-	-																																																																																
PIN No	Encoder Signal	PIN No	Encoder Signal																																																																																
1	-	8	-																																																																																
2	-	9	-																																																																																
3	MA	10	-																																																																																
4	MA	11	-																																																																																
5	SLO	12	-																																																																																
6	SLO	13	-																																																																																
7	OV	14	+5V																																																																																
PLATE		SHIELD																																																																																	
PIN No	Encoder Signal																																																																																		
1	-																																																																																		
2	-																																																																																		
For Signal	F Series Motor S-turn Encoder Cable (Small Capacity)	<p>Note2) APCS-E□□□ES-□</p>	L7S□□□B L7NH□□□□U L7PA□□□□U L7NH□□□□U L7CA□□□□U	All Models of FAL FBL FCL Series	 <p>Motor Side Connector</p> <p>Drive Side Connector (CN2)</p> <table border="1"> <thead> <tr> <th>PIN No</th> <th>Encoder Signal</th> <th>PIN No</th> <th>Encoder Signal</th> </tr> </thead> <tbody> <tr><td>1</td><td>MA</td><td>8</td><td>-</td></tr> <tr><td>2</td><td>SLO</td><td>9</td><td>-</td></tr> <tr><td>3</td><td>-</td><td>3</td><td>MA</td></tr> <tr><td>4</td><td>OV</td><td>4</td><td>MA</td></tr> <tr><td>5</td><td>SHIELD</td><td>5</td><td>SLO</td></tr> <tr><td>6</td><td>MA</td><td>6</td><td>SLO</td></tr> <tr><td>7</td><td>SLO</td><td>7</td><td>OV</td></tr> <tr><td>8</td><td>-</td><td>14</td><td>+5V</td></tr> <tr><td>9</td><td>+5V</td><td colspan="2">PLATE SHIELD</td></tr> </tbody> </table> <p>(Motor Side Connector) (Drive Side Connector)</p> <p>1. Motor Side Connector • Cap Spec.: 2201825-1(Tyco) • Socket Spec.: 2174065-4(Tyco)</p> <p>2. Drive Side Connector (CN2) • Case Spec.: 10314-52A0-008(3M) or SM-14J(Suntone) • Connector Spec.: 10114-3000VE(3M) or SM-14J(Suntone) • Cable Spec.: 3P×0.25SQ or 3P×24AWG</p>	PIN No	Encoder Signal	PIN No	Encoder Signal	1	MA	8	-	2	SLO	9	-	3	-	3	MA	4	OV	4	MA	5	SHIELD	5	SLO	6	MA	6	SLO	7	SLO	7	OV	8	-	14	+5V	9	+5V	PLATE SHIELD																																							
PIN No	Encoder Signal	PIN No	Encoder Signal																																																																																
1	MA	8	-																																																																																
2	SLO	9	-																																																																																
3	-	3	MA																																																																																
4	OV	4	MA																																																																																
5	SHIELD	5	SLO																																																																																
6	MA	6	SLO																																																																																
7	SLO	7	OV																																																																																
8	-	14	+5V																																																																																
9	+5V	PLATE SHIELD																																																																																	

Note1) The three blank squares in model names indicate the type and length of cables. And the designation is as below.

Note2) In case a model name contains a single blank square, the connector can draw towards both front (load) and rear (half-load). [Front Type: no markings, Rear Type: marked -R]
 The FAL Type can only draw towards front.

Cable Length(m)	1	2	3	...	18	19	20
General Cable	N01	N02	N03	...	N18	N19	N20
Robotic Cable	F01	F02	F03	...	F18	F19	F20

Note3) The three blank squares in model names indicate drive capacity. For details regarding the designation, please refer to pages 16 / 22 / 28 / 38 / 44 / 54 / 58 / 66 / 72page

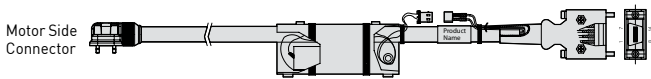
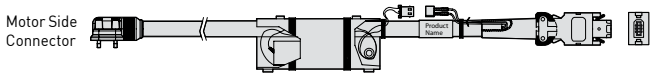
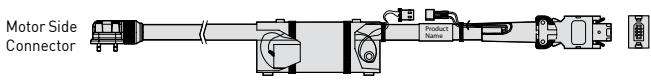
Type	Product Type	Model Name ^{Note1)}	Applicable Drive ^{Note2)}	Applicable Motor	Specifications																																																														
For Signal	L Series Motor M-turn Encoder Cable (Small Capacity)	APCS- E□□□ ES1-□	L7SA□□□B L7NHA□□□U L7PA□□□U L7CA□□□U ^{Note3)}	All Models of FAL FBL FCL Series	 <table border="1" data-bbox="670 548 758 817"> <thead> <tr> <th>PIN No</th> <th>Encoder Signal</th> </tr> </thead> <tbody> <tr><td>1</td><td>MA</td></tr> <tr><td>2</td><td>SLO</td></tr> <tr><td>3</td><td>GND_B</td></tr> <tr><td>4</td><td>OV</td></tr> <tr><td>5</td><td>SHELD</td></tr> <tr><td>6</td><td>MA</td></tr> <tr><td>7</td><td>SLO</td></tr> <tr><td>8</td><td>VOD_B</td></tr> <tr><td>9</td><td>+5V</td></tr> </tbody> </table> <table border="1" data-bbox="949 548 1037 817"> <thead> <tr> <th>PIN No</th> <th>Encoder Signal</th> <th>PIN No</th> <th>Encoder Signal</th> </tr> </thead> <tbody> <tr><td>1</td><td>-</td><td>8</td><td>-</td></tr> <tr><td>2</td><td>-</td><td>9</td><td>-</td></tr> <tr><td>3</td><td>MA</td><td>10</td><td>-</td></tr> <tr><td>4</td><td>MA</td><td>11</td><td>-</td></tr> <tr><td>5</td><td>SLO</td><td>12</td><td>-</td></tr> <tr><td>6</td><td>SLO</td><td>13</td><td>-</td></tr> <tr><td>7</td><td>OV</td><td>14</td><td>+5V</td></tr> <tr><td colspan="2">PLATE</td><td colspan="2">SHIELD</td></tr> </tbody> </table> <table border="1" data-bbox="1308 548 1396 772"> <thead> <tr> <th>PIN No</th> <th>Encoder Signal</th> </tr> </thead> <tbody> <tr><td>1</td><td>BATTERY (VDD_B)</td></tr> <tr><td>2</td><td>BATTERY OV (GND_B)</td></tr> </tbody> </table> <p>(Motor Side Connector) (Drive Side Connector)</p> <p>1. Motor Side Connector <ul style="list-style-type: none"> • Cap Spec.: 2201825-1(Tyco) • Socket Spec.: 2174065-4(Tyco) </p> <p>2. Drive Side Connector(CN2) <ul style="list-style-type: none"> • Case Spec.: 10314-52A0-008(3M) or SM-14J(Suntone) • Connector Spec.: 10114-3000VE(3M) or SM-14J(Suntone) • Cable Spec.: 4P×0.25Q or 4P×24AWG • BATTERY CONNECTOR Spec.: 5267-02A(MOLEX) </p>	PIN No	Encoder Signal	1	MA	2	SLO	3	GND_B	4	OV	5	SHELD	6	MA	7	SLO	8	VOD_B	9	+5V	PIN No	Encoder Signal	PIN No	Encoder Signal	1	-	8	-	2	-	9	-	3	MA	10	-	4	MA	11	-	5	SLO	12	-	6	SLO	13	-	7	OV	14	+5V	PLATE		SHIELD		PIN No	Encoder Signal	1	BATTERY (VDD_B)	2	BATTERY OV (GND_B)
PIN No	Encoder Signal																																																																		
1	MA																																																																		
2	SLO																																																																		
3	GND_B																																																																		
4	OV																																																																		
5	SHELD																																																																		
6	MA																																																																		
7	SLO																																																																		
8	VOD_B																																																																		
9	+5V																																																																		
PIN No	Encoder Signal	PIN No	Encoder Signal																																																																
1	-	8	-																																																																
2	-	9	-																																																																
3	MA	10	-																																																																
4	MA	11	-																																																																
5	SLO	12	-																																																																
6	SLO	13	-																																																																
7	OV	14	+5V																																																																
PLATE		SHIELD																																																																	
PIN No	Encoder Signal																																																																		
1	BATTERY (VDD_B)																																																																		
2	BATTERY OV (GND_B)																																																																		
For Signal	L Series Motor S-turn Encoder Cable (Small Capacity)	^{Note2)} APCS- E□□□ EM-□	ix7M-A- □□□□B	All Models of FAL FBL FCL Series	 <table border="1" data-bbox="670 1108 758 1288"> <thead> <tr> <th>PIN No</th> <th>Encoder Signal</th> <th>PIN No</th> <th>Encoder Signal</th> </tr> </thead> <tbody> <tr><td>1</td><td>MA</td><td>6</td><td>MA</td></tr> <tr><td>2</td><td>SLO</td><td>7</td><td>SLO</td></tr> <tr><td>3</td><td>-</td><td>8</td><td>-</td></tr> <tr><td>4</td><td>OV</td><td>9</td><td>+5V</td></tr> <tr><td>5</td><td>SHIELD</td><td></td><td></td></tr> </tbody> </table> <table border="1" data-bbox="1045 1108 1133 1288"> <thead> <tr> <th>PIN No</th> <th>Encoder Signal</th> <th>PIN No</th> <th>Encoder Signal</th> </tr> </thead> <tbody> <tr><td>1</td><td>+5V</td><td>5</td><td>MA</td></tr> <tr><td>2</td><td>OV</td><td>6</td><td>MA</td></tr> <tr><td>3</td><td>SLO</td><td>Plate</td><td>SHIELD</td></tr> <tr><td>4</td><td>SLO</td><td></td><td></td></tr> </tbody> </table> <p>(Motor Side Connector) (Drive Side Connector)</p> <p>1. Motor Side Connector <ul style="list-style-type: none"> • Cap Spec.: 2201825-1(Tyco) • Socket Spec.: 2174065-4(Tyco) </p> <p>2. Drive Side Connector(CN2) <ul style="list-style-type: none"> • Case Spec.: 10314-52A0-008(3M) or SM-14J(Suntone) • Connector Spec.: 10114-3000VE(3M) or SM-14J(Suntone) • Cable Spec.: 4P×0.25Q or 4P×24AWG </p>	PIN No	Encoder Signal	PIN No	Encoder Signal	1	MA	6	MA	2	SLO	7	SLO	3	-	8	-	4	OV	9	+5V	5	SHIELD			PIN No	Encoder Signal	PIN No	Encoder Signal	1	+5V	5	MA	2	OV	6	MA	3	SLO	Plate	SHIELD	4	SLO																				
PIN No	Encoder Signal	PIN No	Encoder Signal																																																																
1	MA	6	MA																																																																
2	SLO	7	SLO																																																																
3	-	8	-																																																																
4	OV	9	+5V																																																																
5	SHIELD																																																																		
PIN No	Encoder Signal	PIN No	Encoder Signal																																																																
1	+5V	5	MA																																																																
2	OV	6	MA																																																																
3	SLO	Plate	SHIELD																																																																
4	SLO																																																																		
For Signal	L Series Motor M-turn Encoder Cable (Small Capacity)	^{Note2)} APCS- E□□□ EM1-□	ix7M-A- □□□□B	All Models of FAL FBL FCL Series	 <table border="1" data-bbox="670 1534 758 1713"> <thead> <tr> <th>PIN No</th> <th>Encoder Signal</th> <th>PIN No</th> <th>Encoder Signal</th> </tr> </thead> <tbody> <tr><td>1</td><td>MA</td><td>6</td><td>MA</td></tr> <tr><td>2</td><td>SLO</td><td>7</td><td>SLO</td></tr> <tr><td>3</td><td>-</td><td>8</td><td>-</td></tr> <tr><td>4</td><td>OV</td><td>9</td><td>+5V</td></tr> <tr><td>5</td><td>SHIELD</td><td></td><td></td></tr> </tbody> </table> <table border="1" data-bbox="989 1534 1077 1713"> <thead> <tr> <th>PIN No</th> <th>Encoder Signal</th> <th>PIN No</th> <th>Encoder Signal</th> </tr> </thead> <tbody> <tr><td>1</td><td>+5V</td><td>5</td><td>MA</td></tr> <tr><td>2</td><td>OV</td><td>6</td><td>MA</td></tr> <tr><td>3</td><td>SLO</td><td>Plate</td><td>SHIELD</td></tr> <tr><td>4</td><td>SLO</td><td></td><td></td></tr> </tbody> </table> <table border="1" data-bbox="1308 1534 1396 1758"> <thead> <tr> <th>PIN No</th> <th>Encoder Signal</th> </tr> </thead> <tbody> <tr><td>1</td><td>BATTERY (VDD_B)</td></tr> <tr><td>2</td><td>BATTERY OV (GND_B)</td></tr> </tbody> </table> <p>(Motor Side Connector) (Drive Side Connector)</p> <p>1. Motor Side Connector <ul style="list-style-type: none"> • Cap Spec.: 2201825-1(Tyco) • Socket Spec.: 2174065-4(Tyco) </p> <p>2. Drive Side Connector(CN2) <ul style="list-style-type: none"> • Case Spec.: 10314-52A0-008(3M) or SM-14J(Suntone) • Connector Spec.: 10114-3000VE(3M) or SM-14J(Suntone) • Cable Spec.: 4P×0.25Q or 4P×24AWG • BATTERY CONNECTOR Spec.: 5267-02A(MOLEX) </p>	PIN No	Encoder Signal	PIN No	Encoder Signal	1	MA	6	MA	2	SLO	7	SLO	3	-	8	-	4	OV	9	+5V	5	SHIELD			PIN No	Encoder Signal	PIN No	Encoder Signal	1	+5V	5	MA	2	OV	6	MA	3	SLO	Plate	SHIELD	4	SLO			PIN No	Encoder Signal	1	BATTERY (VDD_B)	2	BATTERY OV (GND_B)												
PIN No	Encoder Signal	PIN No	Encoder Signal																																																																
1	MA	6	MA																																																																
2	SLO	7	SLO																																																																
3	-	8	-																																																																
4	OV	9	+5V																																																																
5	SHIELD																																																																		
PIN No	Encoder Signal	PIN No	Encoder Signal																																																																
1	+5V	5	MA																																																																
2	OV	6	MA																																																																
3	SLO	Plate	SHIELD																																																																
4	SLO																																																																		
PIN No	Encoder Signal																																																																		
1	BATTERY (VDD_B)																																																																		
2	BATTERY OV (GND_B)																																																																		

Note1) The three blank squares in model names indicate the type and length of cables. And the designation is as right. In case a model name contains a single blank square, the connector can draw towards both front(load) and rear(half-load).
 [Front Type: no markings, Rear Type: marked -R] The FAL Type can only draw towards front.

Note2) The three blank squares in model names indicate drive capacity.
 For details regarding the designation, please refer to pages 16 / 22 / 28 / 38 / 44 / 54 / 58 / 66 / 72page

Note3) Multi-turn function cannot be used when L7C drive and APMC-F0L00YK product are combined.

Cable Length(m)	1	2	3	...	18	19	20
General Cable	N01	N02	N03	...	N18	N19	N20
Robotic Cable	F01	F02	F03	...	F18	F19	F20

Power Cable [200V]

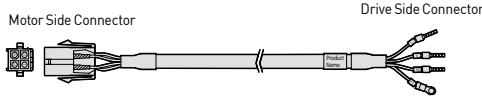
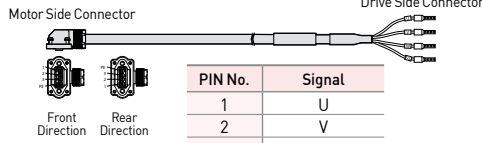
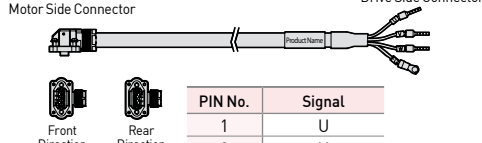
Type	Product Type	Model Name ^{Note1}	Applicable Drive ^{Note2}	Applicable Motor	Specifications										
For Power	H Series Power Cable (Small Capacity)	APCS-P □□□GS	L7SA□□□A L7NHA□□□U L7PA□□□U L7NHFA□□□U	All Models of HB Series	 <table border="1"> <thead> <tr> <th>PIN No.</th> <th>Signal</th> </tr> </thead> <tbody> <tr> <td>1</td> <td>U</td> </tr> <tr> <td>2</td> <td>V</td> </tr> <tr> <td>3</td> <td>W</td> </tr> <tr> <td>4</td> <td>Ground</td> </tr> </tbody> </table> <p>1. Motor Side Connector</p> <ul style="list-style-type: none"> • Cap Spec(4 Position) : 172159-1(AMP) • Socket Spec.: 170362-1(AMP) <p>2. Drive Side Connector(U, V, W, FG)</p> <ul style="list-style-type: none"> • U, V, W Pin Spec. : F1512 • FG Pin Spec.: 1.5X4(Ring Terminal) • Cable Spec.: 4C×0.75SQ or 4C×18AWG 	PIN No.	Signal	1	U	2	V	3	W	4	Ground
PIN No.	Signal														
1	U														
2	V														
3	W														
4	Ground														
For Power	F Series Power Cable (iX7NH)	APCS-P □□□LSX	iX7NHA□□□U	All Models of FAL FBL FCL Series with iX7NH Application	 <table border="1"> <thead> <tr> <th>PIN No.</th> <th>Signal</th> </tr> </thead> <tbody> <tr> <td>1</td> <td>U</td> </tr> <tr> <td>2</td> <td>V</td> </tr> <tr> <td>3</td> <td>W</td> </tr> <tr> <td>PE</td> <td>Ground</td> </tr> </tbody> </table> <p>1. Motor Side Connector</p> <ul style="list-style-type: none"> • CAP Spec: SM-JN8FT04N(Suntone) • Socket Spec.: SMS-201(Suntone) <p>2. Drive Side Connector</p> <ul style="list-style-type: none"> • U, V, W, FG Pin Spec.: 1008 or 010008 • Cable Spec.: 4C×0.75SQ or 4C×18AWG <p>※ Specifications are subject to change without notice.</p>	PIN No.	Signal	1	U	2	V	3	W	PE	Ground
PIN No.	Signal														
1	U														
2	V														
3	W														
PE	Ground														
For Power	F Series (L7C)	APCS-P □□□LSC	L7CA□□□U	All Models of FAL FBL FCL Series with L7C Application	 <table border="1"> <thead> <tr> <th>PIN No.</th> <th>Signal</th> </tr> </thead> <tbody> <tr> <td>1</td> <td>U</td> </tr> <tr> <td>2</td> <td>V</td> </tr> <tr> <td>3</td> <td>W</td> </tr> <tr> <td>PE</td> <td>Ground</td> </tr> </tbody> </table> <p>1. Motor Side Connector</p> <ul style="list-style-type: none"> • CAP Spec: SM-JN8FT04N • Socket Spec.: SMS-201 <p>2. Drive Side Connector</p> <ul style="list-style-type: none"> • U, V, W Pin Spec.: F1506 • Cable Spec.: 4C×0.75SQ or 4C×18AWG 	PIN No.	Signal	1	U	2	V	3	W	PE	Ground
PIN No.	Signal														
1	U														
2	V														
3	W														
PE	Ground														

Note1 The three blank squares in model names indicate the type and length of cables. And the designation is as below.

Cable Length[m]	1	2	3	...	18	19	20
General Cable	N01	N02	N03	...	N18	N19	N20
Robotic Cable	F01	F02	F03	...	F18	F19	F20

Note2 The three blank squares in model names indicate drive capacity. For details regarding the designation, please refer to pages 16 / 22 / 28 / 38 / 44 / 54 / 58 / 66 / 72page

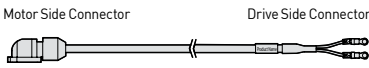
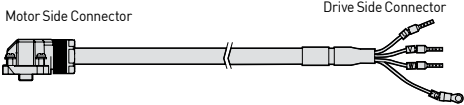
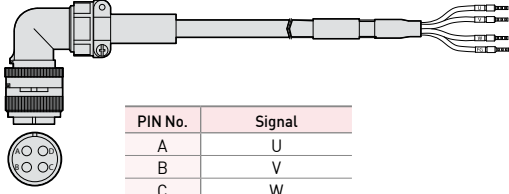
Type	Product Type	Model Name <small>Note1</small>	Applicable Drive <small>Note2</small>	Applicable Motor	Specifications										
For Power	Brake Cable for Flat Motor (Small Capacity)	APCS-B □□□ QS-□	L7SA□□□B L7NHA□□□U L7PA□□□U L7NHFA□□□U L7CA□□□U	All Models of FAL FBL FCL Series	 <table border="1" data-bbox="1027 539 1225 613"> <thead> <tr> <th>PIN No.</th> <th>Signal</th> </tr> </thead> <tbody> <tr> <td>1</td> <td>BK+</td> </tr> <tr> <td>2</td> <td>BK-</td> </tr> </tbody> </table> <p>1. Motor Side Connector</p> <ul style="list-style-type: none"> • Cap Spec: KN5FT02SJ1 • Socket Spec.: ST-KN-S-C1B-3500 <p>2. Drive Side Connector</p> <ul style="list-style-type: none"> • Connecting Terminal Spec.: 1.5×3(Ring Terminal) • Cable Spec.: 2C×0.55SQ or 2C×20AWG 	PIN No.	Signal	1	BK+	2	BK-				
PIN No.	Signal														
1	BK+														
2	BK-														
For Power	L Series Power Cable (Small Capacity)	APCS-P □□□ LS-□	L7SA□□□B L7NHA□□□U L7PA□□□U L7NHFA□□□U	All Models of FAL FBL FCL Series	 <table border="1" data-bbox="1027 987 1254 1106"> <thead> <tr> <th>PIN No.</th> <th>Signal</th> </tr> </thead> <tbody> <tr> <td>1</td> <td>U</td> </tr> <tr> <td>2</td> <td>V</td> </tr> <tr> <td>3</td> <td>W</td> </tr> <tr> <td>PE</td> <td>Ground</td> </tr> </tbody> </table> <p>1. Motor Side Connector</p> <ul style="list-style-type: none"> • Cap Spec: SM-JN8FT04N • Socket Spec.: SMS-201 <p>2. Drive Side Connector</p> <ul style="list-style-type: none"> • U, V, W Pin Spec.: F1512 • FG Pin Spec.: 1.5x4(Ring Terminal) • Cable Spec.: 4C×0.75SQ or 4C×18AWG <p>※ In Case of FAL Products, Please install Power Cable First Before Connecting Encoder Cable</p>	PIN No.	Signal	1	U	2	V	3	W	PE	Ground
PIN No.	Signal														
1	U														
2	V														
3	W														
PE	Ground														
For Power	F Series Power Cable (iX7NH)	APCS-P □□□ HSX1	iX7NHA□□□U	All Models of FE Series with iX7NH Application, FE09A/ FE15A FE06D/ FE11D FE05G/ FE09G FE03M/ FE06M FEP Series	 <table border="1" data-bbox="932 1532 1161 1653"> <thead> <tr> <th>PIN No.</th> <th>Signal</th> </tr> </thead> <tbody> <tr> <td>A</td> <td>U</td> </tr> <tr> <td>B</td> <td>V</td> </tr> <tr> <td>C</td> <td>W</td> </tr> <tr> <td>D</td> <td>Ground</td> </tr> </tbody> </table> <p>1. Motor Side Connector[MS: Military Standard]</p> <ul style="list-style-type: none"> • PLUG Spec: MS 3108A 20-4S <p>2. Drive Side Connector</p> <ul style="list-style-type: none"> • U, V, W Pin Spec.: F1508 • Cable Spec.: 4C×1.5SQ or 4C×15AWG • FG Pin Spec.: F1508 <p>※ Specifications are subject to change without notice.</p>	PIN No.	Signal	A	U	B	V	C	W	D	Ground
PIN No.	Signal														
A	U														
B	V														
C	W														
D	Ground														

Note1) The three blank squares in model names indicate the type and length of cables. And the designation is as below.
 In case a model name contains a single blank square, the connector can draw towards both front(load) and rear(half-load). (Front Type: no markings, Rear Type: marked -R)
 The FAL Type can only draw towards front.

Cable Length(m)	1	2	3	...	18	19	20
General Cable	N01	N02	N03	...	N18	N19	N20
Robotic Cable	F01	F02	F03	...	F18	F19	F20

Note2) The three blank squares in model names indicate drive capacity. For details regarding the designation, please refer to pages 16 / 22 / 28 / 38 / 44 / 54 / 58 / 66 / 72page

Power Cable [200V]

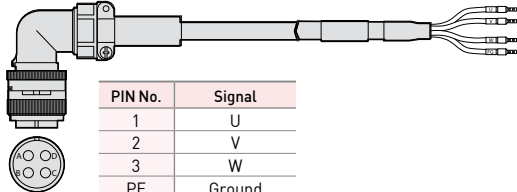
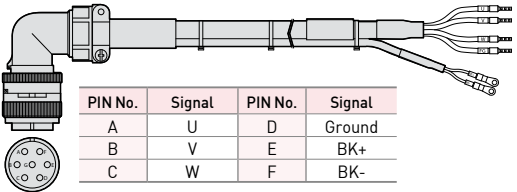
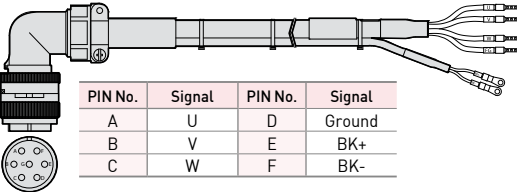
Type	Product Type	Model Name <small>Note1)</small>	Applicable Drive <small>Note2)</small>	Applicable Motor	Specifications																
For Power	Power Cable F Series (iX7NH)	APCS-P □□□HSX	iX7NHA□□□U	FE Series with iX7NH Application, FE22A/ FE30A FE16D/FE22D FE13G/FE17G FE12M	 <table border="1" data-bbox="941 526 1141 638"> <thead> <tr> <th>PIN No.</th> <th>Signal</th> </tr> </thead> <tbody> <tr> <td>1</td> <td>U</td> </tr> <tr> <td>2</td> <td>V</td> </tr> <tr> <td>3</td> <td>W</td> </tr> <tr> <td>PE</td> <td>Ground</td> </tr> </tbody> </table> <p>1. Motor Side Connector(MS: Military Standard) • PLUG Spec: MS 3108A 20-4S</p> <p>2. Drive Side Connector • U, V, W Pin Spec.: F2508 • Cable Spec.: 4Cx2.5SQ or 4Cx14AWG • FG Pin Spec.: F2508</p> <p>※ Specifications are subject to change without notice.</p>	PIN No.	Signal	1	U	2	V	3	W	PE	Ground						
PIN No.	Signal																				
1	U																				
2	V																				
3	W																				
PE	Ground																				
For Power	Power Cable F Series (iX7NH)	APCS-P □□□NBX1	iX7NHA□□□U	FE Series with iX7NH Application, FE09A/FE15A FE06D/FE11D FE05G/FE09G FE03M/FE06M FE09M All Models of FEP Series	 <table border="1" data-bbox="917 996 1236 1086"> <thead> <tr> <th>PIN No.</th> <th>Signal</th> <th>PIN No.</th> <th>Signal</th> </tr> </thead> <tbody> <tr> <td>A</td> <td>U</td> <td>D</td> <td>Ground</td> </tr> <tr> <td>B</td> <td>V</td> <td>E</td> <td>BK+</td> </tr> <tr> <td>C</td> <td>W</td> <td>F</td> <td>BK-</td> </tr> </tbody> </table> <p>1. Motor Side Connector(MS: Military Standard) • PLUG Spec: MS 3108A 20-15S</p> <p>2. Drive Side Connector • U, V, W Pin Spec.: F1508 • Cable Spec.: 4Cx1.5SQ or 4Cx15AWG • FG Pin Spec.: F1508</p> <p>3. Brake Power side Connector • BK Pin Spec.: 1.5x3(Ring Terminal) • Cable Spec.: 2Cx0.75SQ or 2Cx18AWG</p> <p>※ Specifications are subject to change without notice.</p>	PIN No.	Signal	PIN No.	Signal	A	U	D	Ground	B	V	E	BK+	C	W	F	BK-
PIN No.	Signal	PIN No.	Signal																		
A	U	D	Ground																		
B	V	E	BK+																		
C	W	F	BK-																		
For Power	Power Cable F Series (iX7NH)	APCS-P □□□NBX	iX7NHA□□□U	FE Series with iX7NH Application, FE22A/ FE30A FE16D/FE22D FE13G/FE17G FE12M	 <table border="1" data-bbox="917 1489 1236 1579"> <thead> <tr> <th>PIN No.</th> <th>Signal</th> <th>PIN No.</th> <th>Signal</th> </tr> </thead> <tbody> <tr> <td>A</td> <td>U</td> <td>D</td> <td>Ground</td> </tr> <tr> <td>B</td> <td>V</td> <td>E</td> <td>BK+</td> </tr> <tr> <td>C</td> <td>W</td> <td>F</td> <td>BK-</td> </tr> </tbody> </table> <p>1. Motor Side Connector(MS: Military Standard) • PLUG Spec: MS 3108A 20-15S</p> <p>2. Drive Side Connector • U, V, W Pin Spec.: F2508 • Cable Spec.: 4Cx2.5SQ or 4Cx14AWG • FG Pin Spec.: F2508</p> <p>3. Brake Power side Connector • BK Pin Spec.: 1.5x3(Ring Terminal) • Cable Spec.: 2Cx0.75SQ or 2Cx18AWG</p> <p>※ Specifications are subject to change without notice.</p>	PIN No.	Signal	PIN No.	Signal	A	U	D	Ground	B	V	E	BK+	C	W	F	BK-
PIN No.	Signal	PIN No.	Signal																		
A	U	D	Ground																		
B	V	E	BK+																		
C	W	F	BK-																		

Note1) The three blank squares in model names indicate the type and length of cables. And the designation is as below.

Cable Length(m)	1	2	3	...	18	19	20
General Cable	N01	N02	N03	...	N18	N19	N20
Robotic Cable	F01	F02	F03	...	F18	F19	F20

Note2) The three blank squares in model names indicate drive capacity. For details regarding the designation, please refer to pages 16 / 22 / 28 / 38 / 44 / 54 / 58 / 66 / 72page

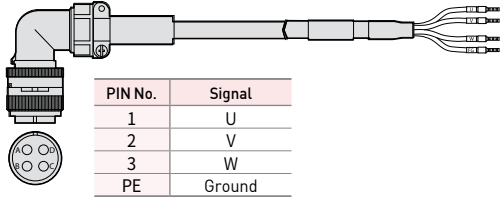
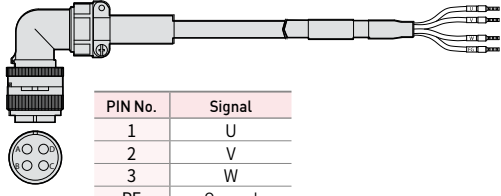
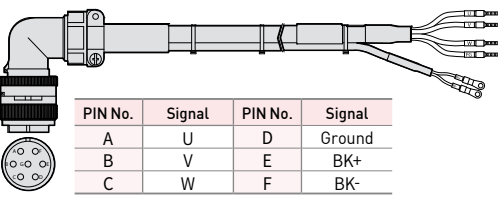
Type	Product Type	Model Name <small>Note1</small>	Applicable Drive <small>Note2</small>	Applicable Motor	Specifications																
For Power	Power Cable E Series F Series (iX7NH)	APCS-P □□□ISX	iX7NHA□□□U	FF Series with iX7NH FF30A/FF30G/ FF20M EE Series EF30A/EF30G EF20M	 <table border="1"> <thead> <tr> <th>PIN No.</th> <th>Signal</th> </tr> </thead> <tbody> <tr> <td>1</td> <td>U</td> </tr> <tr> <td>2</td> <td>V</td> </tr> <tr> <td>3</td> <td>W</td> </tr> <tr> <td>PE</td> <td>Ground</td> </tr> </tbody> </table> <p>1. Motor Side Connector(MS: Military Standard) • PLUG Spec: MS 3108A 22-22S</p> <p>2. Drive Side Connector • U, V, W Pin Spec.: F2508 • Cable Spec.: 4Cx2.5SQ or 4Cx14AWG • FG Pin Spec.: F2508</p> <p>※ Specifications are subject to change without notice.</p>	PIN No.	Signal	1	U	2	V	3	W	PE	Ground						
PIN No.	Signal																				
1	U																				
2	V																				
3	W																				
PE	Ground																				
For Power	Power Cable E Series (iX7NH)	APCS-P □□□ISX1	iX7NHA□□□U	FE Series with iX7NH FF22D/FF20G FF12M EE Series EF20G/EF12M	 <table border="1"> <thead> <tr> <th>PIN No.</th> <th>Signal</th> </tr> </thead> <tbody> <tr> <td>1</td> <td>U</td> </tr> <tr> <td>2</td> <td>V</td> </tr> <tr> <td>3</td> <td>W</td> </tr> <tr> <td>PE</td> <td>Ground</td> </tr> </tbody> </table> <p>1. Motor Side Connector(MS: Military Standard) • PLUG Spec: MS 3108A 22-22S</p> <p>2. Drive Side Connector • U, V, W Pin Spec.: F1508 • Cable Spec.: 4Cx1.5SQ or 4Cx15AWG • FG Pin Spec.: F1508</p> <p>※ Specifications are subject to change without notice.</p>	PIN No.	Signal	1	U	2	V	3	W	PE	Ground						
PIN No.	Signal																				
1	U																				
2	V																				
3	W																				
PE	Ground																				
For Power	Power Cable E Series F Series (iX7NH)	APCS-P □□□PBX	iX7NHA□□□U	FE Series with iX7NH FF30A/FF30G FF20M EE Series EF30A/EF30G EF20M	 <table border="1"> <thead> <tr> <th>PIN No.</th> <th>Signal</th> <th>PIN No.</th> <th>Signal</th> </tr> </thead> <tbody> <tr> <td>A</td> <td>U</td> <td>D</td> <td>Ground</td> </tr> <tr> <td>B</td> <td>V</td> <td>E</td> <td>BK+</td> </tr> <tr> <td>C</td> <td>W</td> <td>F</td> <td>BK-</td> </tr> </tbody> </table> <p>1. Motor Side Connector(MS: Military Standard) • PLUG Spec: MS 3108A 24-10S</p> <p>2. Drive Side Connector • U, V, W Pin Spec.: F2508 • Cable Spec.: 4Cx1.5SQ or 4Cx15AWG • FG Pin Spec.: F1508</p> <p>3. Brake Power side Connector • BK Pin Spec.: 1.5x3(Ring Terminal) • Cable Spec.: 2Cx0.75SQ or 2Cx18AWG</p> <p>※ Specifications are subject to change without notice.</p>	PIN No.	Signal	PIN No.	Signal	A	U	D	Ground	B	V	E	BK+	C	W	F	BK-
PIN No.	Signal	PIN No.	Signal																		
A	U	D	Ground																		
B	V	E	BK+																		
C	W	F	BK-																		

Note1 The three blank squares in model names indicate the type and length of cables. And the designation is as below.

Cable Length(m)	1	2	3	...	18	19	20
Cable Length(m)	N01	N02	N03	...	N18	N19	N20
Robotic Cable	F01	F02	F03	...	F18	F19	F20

Note2 The three blank squares in model names indicate drive capacity. For details regarding the designation, please refer to pages 16 / 22 / 28 / 38 / 44 / 54 / 58 / 66 / 72page

Power Cable [200V]

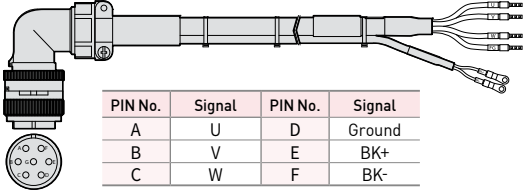
Type	Product Type	Model Name <small>Note1</small>	Applicable Drive <small>Note2</small>	Applicable Motor	Specifications																
For Power	Power Cable E Series F Series (iX7NH)	APCS-P □□□PBX1	iX7NHA□□□U	FE Series with iX7NH FF22D/FF20G FF12M EE Series EF20G/EF12M	 <table border="1" data-bbox="967 555 1289 654"> <thead> <tr> <th>PIN No.</th> <th>Signal</th> <th>PIN No.</th> <th>Signal</th> </tr> </thead> <tbody> <tr> <td>A</td> <td>U</td> <td>D</td> <td>Ground</td> </tr> <tr> <td>B</td> <td>V</td> <td>E</td> <td>BK+</td> </tr> <tr> <td>C</td> <td>W</td> <td>F</td> <td>BK-</td> </tr> </tbody> </table> <p> 1. Motor Side Connector (MS: Military Standard) • PLUG Spec.: MS 3108A 24-10S 2. Drive Side Connector • U, V, W Pin Spec.: F2508 • Cable Spec.: 4Cx2.5SQ or 4Cx14AWG • FG Pin Spec.: F2508 3. Brake Power side Connector • BK Pin Spec.: 1.5x3(Ring Terminal) • Cable Spec.: 2Cx0.75SQ or 2Cx18AWG ※ Specifications are subject to change without notice. </p>	PIN No.	Signal	PIN No.	Signal	A	U	D	Ground	B	V	E	BK+	C	W	F	BK-
PIN No.	Signal	PIN No.	Signal																		
A	U	D	Ground																		
B	V	E	BK+																		
C	W	F	BK-																		

Note1 The three blank squares in model names indicate the type and length of cables. And the designation is as below.

Cable Length(m)	1	2	3	...	18	19	20
General Cable	N01	N02	N03	...	N18	N19	N20
Robotic Cable	F01	F02	F03	...	F18	F19	F20

Note2 The three blank squares in model names indicate drive capacity. For details regarding the designation, please refer to pages 16 / 22 / 28 / 38 / 44 / 54 / 58 / 66 / 72page

Power Cable [Common use for 200V and 400V]

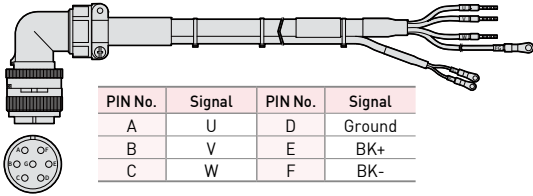
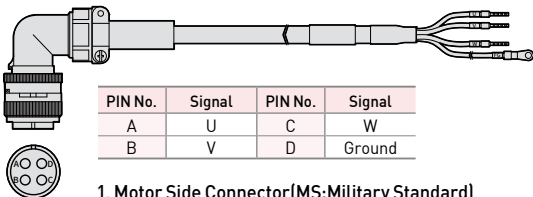
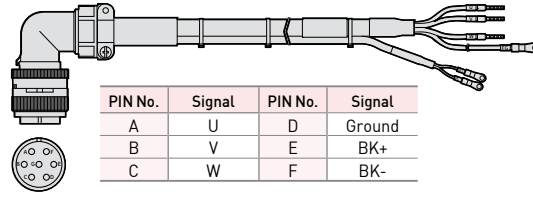
Type	Product Type	Model Name ^{Note1}	Applicable Drive ^{Note2}	Applicable Motor	Specifications																
For Power	Power Cable (Brake Type)	APCS-P □□□NB1	L7S□□□□□ L7NH□□□□□ L7NHFA□□□□□ L7P□□□□□	FE Series FE09A/FE15A FE06D/FE11D FE05G/FE09G FE03M/FE06M FE09M All Model of FEP Series EE Series EE09A/EE15A EE06D/EE11D EE03M/EE06M EE09M	 <table border="1"> <thead> <tr> <th>PIN No.</th> <th>Signal</th> <th>PIN No.</th> <th>Signal</th> </tr> </thead> <tbody> <tr> <td>A</td> <td>U</td> <td>D</td> <td>Ground</td> </tr> <tr> <td>B</td> <td>V</td> <td>E</td> <td>BK+</td> </tr> <tr> <td>C</td> <td>W</td> <td>F</td> <td>BK-</td> </tr> </tbody> </table> <p>1. Motor Side Connector[MS: Military Standard] • PLUG Spec: MS 3108A 20-15S</p> <p>2. Drive Side Connector • U, V, W Pin Spec.: F1512 • Cable Spec.: 4Cx1.5SQ or 4Cx15AWG • FG Pin Spec.: 1.5x4(Ring Terminal)</p> <p>3. Brake Power side Connector • BK Pin Spec.: 1.5x3(Ring Terminal) • Cable Spec.: 2Cx0.75SQ or 2Cx18AWG</p>	PIN No.	Signal	PIN No.	Signal	A	U	D	Ground	B	V	E	BK+	C	W	F	BK-
PIN No.	Signal	PIN No.	Signal																		
A	U	D	Ground																		
B	V	E	BK+																		
C	W	F	BK-																		
For Power	Power Cable	APCS-P □□□HS1	L7S□□□□□ L7NH□□□□□ L7NHFA□□□□□ L7P□□□□□	FE Series FE09A/FE15A FE06D/FE11D FE05G/FE09G FE03M/FE06M FE09M All Model of FEP Series HE Series HE09A/HE15A EE Series EE09A/EE15A EE06D/EE11D EE03M/EE06M EE09M	 <table border="1"> <thead> <tr> <th>PIN No.</th> <th>Signal</th> <th>PIN No.</th> <th>Signal</th> </tr> </thead> <tbody> <tr> <td>A</td> <td>U</td> <td>C</td> <td>W</td> </tr> <tr> <td>B</td> <td>V</td> <td>D</td> <td>Ground</td> </tr> </tbody> </table> <p>1. Motor Side Connector[MS: Military Standard] • PLUG Spec: MS 3108A 20-4S</p> <p>2. Drive Side Connector • U, V, W Pin Spec.: F1512 • Cable Spec.: 4Cx1.5SQ or 4Cx15AWG • FG Pin Spec.: 1.5x4(Ring Terminal)</p>	PIN No.	Signal	PIN No.	Signal	A	U	C	W	B	V	D	Ground				
PIN No.	Signal	PIN No.	Signal																		
A	U	C	W																		
B	V	D	Ground																		
For Power	Power Cable (Brake Type)	APCS-P □□□NB	L7SA□□□□□ L7NHA□□□□□ L7NHFA□□□□□ L7PA□□□□□	FE Series FE22A/FE30A FE16D/FE22D FE13G/FE17G FE12M EE Series EE22A/EE30A EE16D/EE22D EE12M	 <table border="1"> <thead> <tr> <th>PIN No.</th> <th>Signal</th> <th>PIN No.</th> <th>Signal</th> </tr> </thead> <tbody> <tr> <td>A</td> <td>U</td> <td>D</td> <td>Ground</td> </tr> <tr> <td>B</td> <td>V</td> <td>E</td> <td>BK+</td> </tr> <tr> <td>C</td> <td>W</td> <td>F</td> <td>BK-</td> </tr> </tbody> </table> <p>1. Motor Side Connector[MS: Military Standard] • PLUG Spec: MS 3108A 20-15S</p> <p>2. Drive Side Connector • U, V, W Pin Spec.: F2512 • Cable Spec.: 4Cx2.5SQ or 4Cx14AWG • FG Pin Spec.: 2.5x4(Ring Terminal)</p> <p>3. Brake Power side Connector • BK Pin Spec.: 1.5x3(Ring Terminal) • Cable Spec.: 2Cx0.75SQ or 2Cx18AWG</p>	PIN No.	Signal	PIN No.	Signal	A	U	D	Ground	B	V	E	BK+	C	W	F	BK-
PIN No.	Signal	PIN No.	Signal																		
A	U	D	Ground																		
B	V	E	BK+																		
C	W	F	BK-																		

^{Note1} The three blank squares in model names indicate the type and length of cables. And the designation is as below.

Cable Length(m)	1	2	3	...	18	19	20
General Cable	N01	N02	N03	...	N18	N19	N20
Robotic Cable	F01	F02	F03	...	F18	F19	F20

^{Note2} The three blank squares in model names indicate drive capacity. For details regarding the designation, please refer to pages 16 / 22 / 28 / 38 / 44 / 54 / 58 / 66 / 72page

Power Cable [Common use for 200V and 400V]

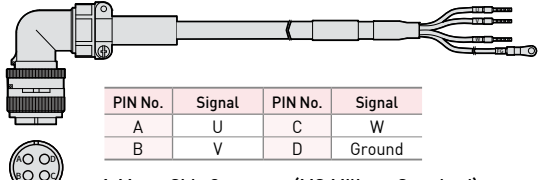
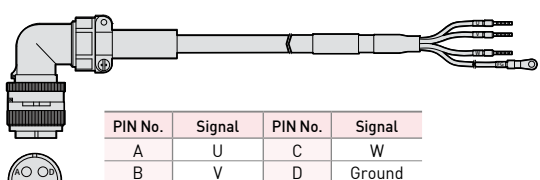
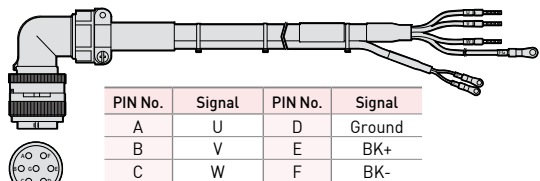
Type	Product Type	Model Name <small>Note1</small>	Applicable Drive <small>Note2</small>	Applicable Motor	Specifications												
For Power	Power Cable	APCS-P □□□HS	L7SA□□□□ L7NHA□□□□U L7NHFA□□□□U L7PA□□□□U	FE Series FE22A/FE30A FE16D/FE22D FE13G/FE17G FE12M	 <table border="1"> <thead> <tr> <th>PIN No.</th> <th>Signal</th> <th>PIN No.</th> <th>Signal</th> </tr> </thead> <tbody> <tr> <td>A</td> <td>U</td> <td>C</td> <td>W</td> </tr> <tr> <td>B</td> <td>V</td> <td>D</td> <td>Ground</td> </tr> </tbody> </table> <p>1. Motor Side Connector[MS: Military Standard]</p> <ul style="list-style-type: none"> • PLUG Spec: MS 3108A 20-4S <p>2. Drive Side Connector</p> <ul style="list-style-type: none"> • U, V, W Pin Spec.: F2512 • Cable Spec.: 4Cx2.5SQ or 4Cx14AWG • FG Pin Spec.: 2.5x4(Ring Terminal) 	PIN No.	Signal	PIN No.	Signal	A	U	C	W	B	V	D	Ground
				PIN No.		Signal	PIN No.	Signal									
				A		U	C	W									
B	V	D	Ground														
EE Series EE22A/EE30A EE16D/EE22D EE12M																	
FF Series FF22D/FF20G FF12M	 <table border="1"> <thead> <tr> <th>PIN No.</th> <th>Signal</th> <th>PIN No.</th> <th>Signal</th> </tr> </thead> <tbody> <tr> <td>A</td> <td>U</td> <td>C</td> <td>W</td> </tr> <tr> <td>B</td> <td>V</td> <td>D</td> <td>Ground</td> </tr> </tbody> </table> <p>1. Motor Side Connector[MS: Military Standard]</p> <ul style="list-style-type: none"> • PLUG Spec: MS 3108A 22-22S <p>2. Drive Side Connector</p> <ul style="list-style-type: none"> • U, V, W Pin Spec.: F1512 • Cable Spec.: 4Cx1.5SQ or 4Cx15AWG • FG Pin Spec.: 1.5x4(Ring Terminal) 	PIN No.	Signal	PIN No.	Signal	A	U	C	W	B	V	D	Ground				
PIN No.		Signal	PIN No.	Signal													
A		U	C	W													
B	V	D	Ground														
FG Series FG22D/FG20G FG12M																	
FFP Series FFP30A/FFP22D FFP35D/FFP20G FFP30G/FFP12M FFP20M/FFP30M	 <table border="1"> <thead> <tr> <th>PIN No.</th> <th>Signal</th> <th>PIN No.</th> <th>Signal</th> </tr> </thead> <tbody> <tr> <td>A</td> <td>U</td> <td>D</td> <td>Ground</td> </tr> <tr> <td>B</td> <td>V</td> <td>E</td> <td>BK+</td> </tr> <tr> <td>C</td> <td>W</td> <td>F</td> <td>BK-</td> </tr> </tbody> </table> <p>1. Motor Side Connector[MS: Military Standard]</p> <ul style="list-style-type: none"> • PLUG Spec: MS 3108A 24-10S <p>2. Drive Side Connector</p> <ul style="list-style-type: none"> • U, V, W Pin Spec.: F1512 • Cable Spec.: 4Cx1.5SQ or 4Cx15AWG • FG Pin Spec.: 1.5x4(Ring Terminal) <p>3. Brake Power side Connector</p> <ul style="list-style-type: none"> • BK Pin Spec.: 1.5x3(Ring Terminal) • Cable Spec.: 2Cx0.75SQ or 2Cx18AWG 	PIN No.	Signal	PIN No.	Signal	A	U	D	Ground	B	V	E	BK+	C	W	F	BK-
PIN No.		Signal	PIN No.	Signal													
A		U	D	Ground													
B	V	E	BK+														
C	W	F	BK-														
FGP Series FGP22D/FGP35D FGP20G/FGP30G FGP12M/FGP20M FGP30M																	
EF Series EF20G/EF12M																	

Note1 The three blank squares in model names indicate the type and length of cables. And the designation is as below.

Cable Length(m)	1	2	3	...	18	19	20
General Cable	N01	N02	N03	...	N18	N19	N20
Robotic Cable	F01	F02	F03	...	F18	F19	F20

Note2 The three blank squares in model names indicate drive capacity. For details regarding the designation, please refer to pages 16 / 22 / 28 / 38 / 44 / 54 / 58 / 66 / 72page

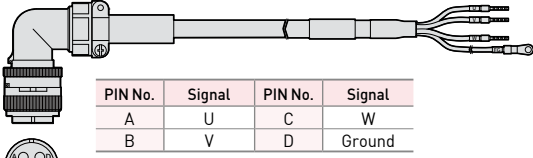
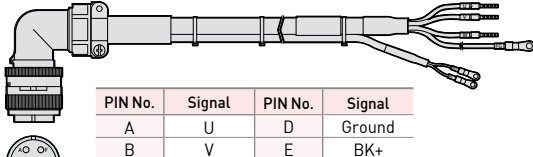
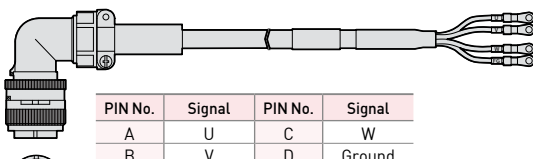
Type	Product Type	Model Name ^{Note1)}	Applicable Drive ^{Note2)}	Applicable Motor	Specifications																
For Power	Power Cable	APCS-P □□□IS	L7SA□□□□ L7NHA□□□□U L7NHFA□□□□U L7PA□□□□U	FF Series FF30A/FF35D FF30G/FF20M FF30M FG Series FG35D/FG30G FG20M/FG30M EF Series EF30A/EF30G EF20M/EF30M	 <table border="1" data-bbox="901 537 1220 616"> <thead> <tr> <th>PIN No.</th> <th>Signal</th> <th>PIN No.</th> <th>Signal</th> </tr> </thead> <tbody> <tr> <td>A</td> <td>U</td> <td>C</td> <td>W</td> </tr> <tr> <td>B</td> <td>V</td> <td>D</td> <td>Ground</td> </tr> </tbody> </table> <p>1. Motor Side Connector(MS: Military Standard) • PLUG Spec: MS 3108A 22-22S</p> <p>2. Drive Side Connector • U, V, W Pin Spec.: F2512 • Cable Spec.: 4Cx2.5SQ or 4Cx14AWG • FG Pin Spec.: 2.5x4(Ring Terminal)</p>	PIN No.	Signal	PIN No.	Signal	A	U	C	W	B	V	D	Ground				
PIN No.	Signal	PIN No.	Signal																		
A	U	C	W																		
B	V	D	Ground																		
For Power	Power Cable (Brake Type)	APCS-P □□□PB	L7SA□□□□ L7NHA□□□□U L7NHFA□□□□U L7PA□□□□U	FF Series FF30A/FF35D FF30G/FF20M FF30M EF Series EF30A/EF30G EF20M/EF30M	 <table border="1" data-bbox="901 929 1220 1019"> <thead> <tr> <th>PIN No.</th> <th>Signal</th> <th>PIN No.</th> <th>Signal</th> </tr> </thead> <tbody> <tr> <td>A</td> <td>U</td> <td>D</td> <td>Ground</td> </tr> <tr> <td>B</td> <td>V</td> <td>E</td> <td>BK+</td> </tr> <tr> <td>C</td> <td>W</td> <td>F</td> <td>BK-</td> </tr> </tbody> </table> <p>1. Motor Side Connector(MS: Military Standard) • PLUG Spec: MS 3108A 24-10S</p> <p>2. Drive Side Connector • U, V, W Pin Spec.: F2512 • Cable Spec.: 4Cx2.5SQ or 4Cx14AWG • FG Pin Spec.: 2.5x4(Ring Terminal)</p> <p>3. Brake Power side Connector • BK Pin Spec.: 1.5x3(Ring Terminal) • Cable Spec.: 2Cx0.75SQ or 2Cx18AWG</p>	PIN No.	Signal	PIN No.	Signal	A	U	D	Ground	B	V	E	BK+	C	W	F	BK-
PIN No.	Signal	PIN No.	Signal																		
A	U	D	Ground																		
B	V	E	BK+																		
C	W	F	BK-																		
For Power	Power Cable	APCS-P □□□JS1	L7SB□□□□ L7NHB□□□□U L7PB□□□□U	FFP Series FFP50A/ FFP55D FFP75D/ FFP44G FFP60G/ FFP44M FGP Series FGP55D/ FGP75D FGP44G/ FGP60G FGP44M	 <table border="1" data-bbox="901 1422 1220 1500"> <thead> <tr> <th>PIN No.</th> <th>Signal</th> <th>PIN No.</th> <th>Signal</th> </tr> </thead> <tbody> <tr> <td>A</td> <td>U</td> <td>C</td> <td>W</td> </tr> <tr> <td>B</td> <td>V</td> <td>D</td> <td>Ground</td> </tr> </tbody> </table> <p>1. Motor Side Connector(MS: Military Standard) • PLUG Spec: MS 3108A 22-22S</p> <p>2. Drive Side Connector • U, V, W Pin Spec.: 4.0x5(Ring Terminal) • Cable Spec.: 4Cx4.0SQ or 4Cx11AWG • FG Pin Spec.: 4.0x5(Ring Terminal)</p>	PIN No.	Signal	PIN No.	Signal	A	U	C	W	B	V	D	Ground				
PIN No.	Signal	PIN No.	Signal																		
A	U	C	W																		
B	V	D	Ground																		

Note1) The three blank squares in model names indicate the type and length of cables. And the designation is as below.

Cable Length(m)	1	2	3	...	18	19	20
General Cable	N01	N02	N03	...	N18	N19	N20
Robotic Cable	F01	F02	F03	...	F18	F19	F20

Note2) The three blank squares in model names indicate drive capacity. For details regarding the designation, please refer to pages 16 / 22 / 28 / 38 / 44 / 54 / 58 / 66 / 72page

Power Cable [Common use for 200V and 400V]

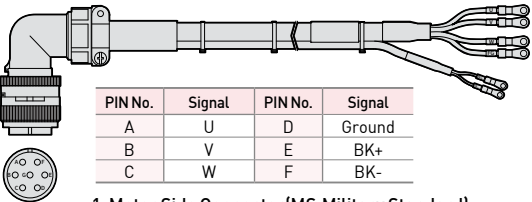
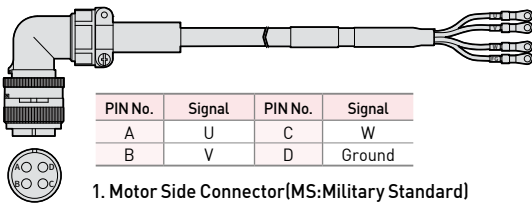
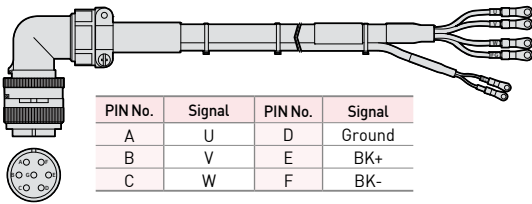
Type	Product Type	Model Name <small>Note1</small>	Applicable Drive <small>Note2</small>	Applicable Motor	Specifications																
For Power	Power Cable (Brake Type)	APCS-P □□□LB1	L7SB□□□□ L7NHB□□□□U L7PB□□□□U	FFP Series FFP50A/ FFP55D FFP75D/ FFP44G FFP60G/ FFP44M	 <table border="1"> <thead> <tr> <th>PIN No.</th> <th>Signal</th> <th>PIN No.</th> <th>Signal</th> </tr> </thead> <tbody> <tr> <td>A</td> <td>U</td> <td>D</td> <td>Ground</td> </tr> <tr> <td>B</td> <td>V</td> <td>E</td> <td>BK+</td> </tr> <tr> <td>C</td> <td>W</td> <td>F</td> <td>BK-</td> </tr> </tbody> </table> <ol style="list-style-type: none"> Motor Side Connector (MS: Military Standard) <ul style="list-style-type: none"> • PLUG Spec: MS 3108A 24-10S Drive Side Connector <ul style="list-style-type: none"> • U, V, W Pin Spec.: 4.0x5 (Ring Terminal) • Cable Spec.: 4Cx4.0SQ or 4Cx11AWG • FG Pin Spec.: 4.0x5 (Ring Terminal) Brake Power side Connector <ul style="list-style-type: none"> • BK Pin Spec.: 1.5x3 (Ring Terminal) • Cable Spec.: 2Cx0.75SQ or 2Cx18AWG 	PIN No.	Signal	PIN No.	Signal	A	U	D	Ground	B	V	E	BK+	C	W	F	BK-
PIN No.	Signal	PIN No.	Signal																		
A	U	D	Ground																		
B	V	E	BK+																		
C	W	F	BK-																		
For Power	Power Cable	APCS-P □□□JS	L7SA□□□□ L7NHA□□□□U L7NHFA□□□□U L7PA□□□□U	FF Series FF50A/ FF55D FF44G/ FF44M FG Series FG55D/ FG44G FG44M EF Series EF50A/ EF44G EF44M	 <table border="1"> <thead> <tr> <th>PIN No.</th> <th>Signal</th> <th>PIN No.</th> <th>Signal</th> </tr> </thead> <tbody> <tr> <td>A</td> <td>U</td> <td>C</td> <td>W</td> </tr> <tr> <td>B</td> <td>V</td> <td>D</td> <td>Ground</td> </tr> </tbody> </table> <ol style="list-style-type: none"> Motor Side Connector (MS: Military Standard) <ul style="list-style-type: none"> • PLUG Spec: MS 3108A 22-22S Drive Side Connector <ul style="list-style-type: none"> • U, V, W Pin Spec.: 6.0x5 (Ring Terminal) • Cable Spec.: 4Cx6.0SQ or 4Cx10AWG • FG Pin Spec.: 6.0x5 (Ring Terminal) 	PIN No.	Signal	PIN No.	Signal	A	U	C	W	B	V	D	Ground				
PIN No.	Signal	PIN No.	Signal																		
A	U	C	W																		
B	V	D	Ground																		
For Power	Power Cable (Brake Type)	APCS-P □□□LB	L7SA□□□□ L7NHA□□□□U L7NHFA□□□□U L7PA□□□□U	FF Series FF50A/ FF55D FF44G/ FF44M EF Series EF50A/ EF44G EF44M	 <table border="1"> <thead> <tr> <th>PIN No.</th> <th>Signal</th> <th>PIN No.</th> <th>Signal</th> </tr> </thead> <tbody> <tr> <td>A</td> <td>U</td> <td>D</td> <td>Ground</td> </tr> <tr> <td>B</td> <td>V</td> <td>E</td> <td>BK+</td> </tr> <tr> <td>C</td> <td>W</td> <td>F</td> <td>BK-</td> </tr> </tbody> </table> <ol style="list-style-type: none"> Motor Side Connector (MS: Military Standard) <ul style="list-style-type: none"> • PLUG Spec: MS 3108A 24-10S Drive Side Connector <ul style="list-style-type: none"> • U, V, W Pin Spec.: 6.0x5 (Ring Terminal) • Cable Spec.: 4Cx6.0SQ or 4Cx10AWG • FG Pin Spec.: 6.0x5 (Ring Terminal) Brake Power Side Connector <ul style="list-style-type: none"> • BK Pin Spec.: 1.5x3 (Ring Terminal) • Cable Spec.: 2Cx0.75SQ or 2Cx18AWG 	PIN No.	Signal	PIN No.	Signal	A	U	D	Ground	B	V	E	BK+	C	W	F	BK-
PIN No.	Signal	PIN No.	Signal																		
A	U	D	Ground																		
B	V	E	BK+																		
C	W	F	BK-																		

Note1) The three blank squares in model names indicate the type and length of cables. And the designation is as below.

Cable Length(m)	1	2	3	...	18	19	20
General Cable	N01	N02	N03	...	N18	N19	N20
Robotic Cable	F01	F02	F03	...	F18	F19	F20

Note2) The three blank squares in model names indicate drive capacity. For details regarding the designation, please refer to pages 16 / 22 / 28 / 38 / 44 / 54 / 58 / 66 / 72page

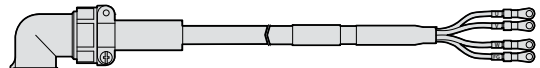
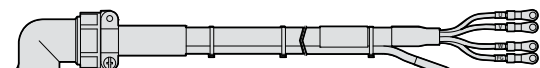
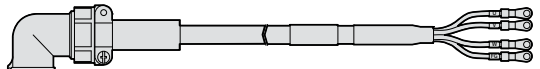
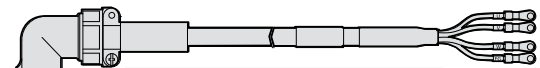
Type	Product Type	Model Name ^{Note1)}	Applicable Drive ^{Note2)}	Applicable Motor	Specifications																
For Power	Power Cable	APCS-P □□□JS2	L7SA□□□□ L7NHA□□□□U L7NHFA□□□□U L7PA□□□□U	FF Series FF75D/FF60G FG Series FG75D/FG60G EF Series EF60G/EF75G	 <table border="1" data-bbox="917 526 1236 593"> <thead> <tr> <th>PIN No.</th> <th>Signal</th> <th>PIN No.</th> <th>Signal</th> </tr> </thead> <tbody> <tr> <td>A</td> <td>U</td> <td>C</td> <td>W</td> </tr> <tr> <td>B</td> <td>V</td> <td>D</td> <td>Ground</td> </tr> </tbody> </table> <p>1. Motor Side Connector[MS: Military Standard] • PLUG Spec.: MS 3108A 22-22S</p> <p>2. Drive Side Connector • U, V, W Pin Spec.: 10.0x5(Ring Terminal) • Cable Spec.: 4Cx10.0SQ or 4Cx8AWG • FG Pin Spec.: 10.0x5(Ring Terminal)</p>	PIN No.	Signal	PIN No.	Signal	A	U	C	W	B	V	D	Ground				
PIN No.	Signal	PIN No.	Signal																		
A	U	C	W																		
B	V	D	Ground																		
For Power	Power Cable (Brake Type)	APCS-P □□□LB2	L7SA□□□□ L7NHA□□□□U L7NHFA□□□□U L7PA□□□□U	FF Series FF75D/ FF60G EF Series EF60G	 <table border="1" data-bbox="917 873 1236 974"> <thead> <tr> <th>PIN No.</th> <th>Signal</th> <th>PIN No.</th> <th>Signal</th> </tr> </thead> <tbody> <tr> <td>A</td> <td>U</td> <td>D</td> <td>Ground</td> </tr> <tr> <td>B</td> <td>V</td> <td>E</td> <td>BK+</td> </tr> <tr> <td>C</td> <td>W</td> <td>F</td> <td>BK-</td> </tr> </tbody> </table> <p>1. Motor Side Connector[MS: Military Standard] • PLUG Spec.: MS 3108A 24-10S</p> <p>2. Drive Side Connector • U, V, W Pin Spec.: 10.0x5(Ring Terminal) • Cable Spec.: 4Cx10.0SQ or 4Cx8AWG • FG Pin Spec.: 10.0x5(Ring Terminal)</p> <p>3. Brake Power side Connector • BK Pin Spec.: 1.5x3(Ring Terminal) • Cable Spec.: 2Cx0.75SQ or 2Cx18AWG</p>	PIN No.	Signal	PIN No.	Signal	A	U	D	Ground	B	V	E	BK+	C	W	F	BK-
PIN No.	Signal	PIN No.	Signal																		
A	U	D	Ground																		
B	V	E	BK+																		
C	W	F	BK-																		
For Power	Power Cable	APCS-P □□□MS1	L7SB□□□□ L7NHB□□□□U L7PB□□□□U	FFP Series FFP75G FGP Series FGP60M/ FGP110D/ FGP85G/ FGP110G	 <table border="1" data-bbox="917 1344 1236 1422"> <thead> <tr> <th>PIN No.</th> <th>Signal</th> <th>PIN No.</th> <th>Signal</th> </tr> </thead> <tbody> <tr> <td>A</td> <td>U</td> <td>C</td> <td>W</td> </tr> <tr> <td>B</td> <td>V</td> <td>D</td> <td>Ground</td> </tr> </tbody> </table> <p>1. Motor Side Connector[MS: Military Standard] • PLUG Spec.: MS 3108A 32-17S</p> <p>2. Drive Side Connector • U, V, W Pin Spec.: 6.0x5(Ring Terminal) • Cable Spec.: 4Cx6.0SQ or 4Cx10AWG • FG Pin Spec.: 6.0x5(Ring Terminal)</p>	PIN No.	Signal	PIN No.	Signal	A	U	C	W	B	V	D	Ground				
PIN No.	Signal	PIN No.	Signal																		
A	U	C	W																		
B	V	D	Ground																		
For Power	Power Cable	APCS-P □□□MS	L7S□□□□□ L7NH□□□□□U L7NH□□□□□U L7P□□□□□U	FF Series FF75G FG Series FG60M FGP Series FGP150G	 <table border="1" data-bbox="917 1691 1236 1769"> <thead> <tr> <th>PIN No.</th> <th>Signal</th> <th>PIN No.</th> <th>Signal</th> </tr> </thead> <tbody> <tr> <td>A</td> <td>U</td> <td>C</td> <td>W</td> </tr> <tr> <td>B</td> <td>V</td> <td>D</td> <td>Ground</td> </tr> </tbody> </table> <p>1. Motor Side Connector[MS: Military Standard] • PLUG Spec.: MS 3108A 32-17S</p> <p>2. Drive Side Connector • U, V, W Pin Spec.: 10.0x5(Ring Terminal) • Cable Spec.: 4Cx10.0SQ or 4Cx8AWG • FG Pin Spec.: 10.0x5(Ring Terminal)</p>	PIN No.	Signal	PIN No.	Signal	A	U	C	W	B	V	D	Ground				
PIN No.	Signal	PIN No.	Signal																		
A	U	C	W																		
B	V	D	Ground																		

Note1) The three blank squares in model names indicate the type and length of cables. And the designation is as below.

Cable Length(m)	1	2	3	...	18	19	20
General Cable	N01	N02	N03	...	N18	N19	N20
Robotic Cable	F01	F02	F03	...	F18	F19	F20

Note2) The three blank squares in model names indicate drive capacity. For details regarding the designation, please refer to pages 16 / 22 / 28 / 38 / 44 / 54 / 58 / 66 / 72page

Power Cable [Common use for 200V and 400V]

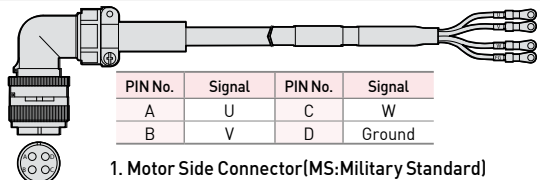
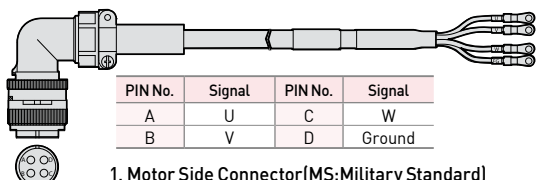
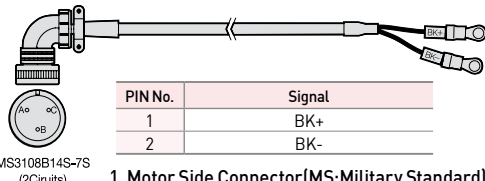
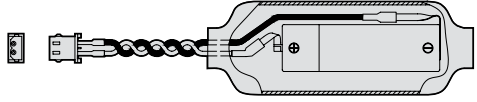
Type	Product Type	Model Name ^{Note1}	Applicable Drive ^{Note2}	Applicable Motor	Specifications												
For Power	Power Cable	APCS-P □□□OS	L7SA□□□□ L7NHA□□□□U L7PA□□□□U	FG Series FG110D/ FG85G FG110G	 <table border="1"> <thead> <tr> <th>PIN No.</th> <th>Signal</th> <th>PIN No.</th> <th>Signal</th> </tr> </thead> <tbody> <tr> <td>A</td> <td>U</td> <td>C</td> <td>W</td> </tr> <tr> <td>B</td> <td>V</td> <td>D</td> <td>Ground</td> </tr> </tbody> </table> <p>1. Motor Side Connector (MS: Military Standard) • PLUG Spec: MS 3108A 32-17S</p> <p>2. Drive Side Connector • U, V, W Pin Spec.: 16.0x6 (Ring Terminal) • Cable Spec.: 4Cx16.0SQ or 4Cx5AWG • FG Pin Spec.: 16.0x6 (Ring Terminal)</p>	PIN No.	Signal	PIN No.	Signal	A	U	C	W	B	V	D	Ground
PIN No.	Signal	PIN No.	Signal														
A	U	C	W														
B	V	D	Ground														
For Power	Power Cable	APCS-P □□□VS	L7SA□□□□ L7NHA□□□□U L7PA□□□□U	FG Series FG150G	 <table border="1"> <thead> <tr> <th>PIN No.</th> <th>Signal</th> <th>PIN No.</th> <th>Signal</th> </tr> </thead> <tbody> <tr> <td>A</td> <td>U</td> <td>C</td> <td>W</td> </tr> <tr> <td>B</td> <td>V</td> <td>D</td> <td>Ground</td> </tr> </tbody> </table> <p>1. Motor Side Connector (MS: Military Standard) • PLUG Spec: MS 3108A 32-17S</p> <p>2. Drive Side Connector • U, V, W Pin Spec.: 25.0x6 (Ring Terminal) • Cable Spec.: 4Cx25.0SQ or 4Cx3AWG • FG Pin Spec.: 22.0x6 (Ring Terminal)</p>	PIN No.	Signal	PIN No.	Signal	A	U	C	W	B	V	D	Ground
PIN No.	Signal	PIN No.	Signal														
A	U	C	W														
B	V	D	Ground														
For Power	Brake Cable	APCS-P □□□SB	L7S□□□□□ L7NH□□□□□U L7NHFA□□□□U L7P□□□□□U	All Model of FG Series	 <table border="1"> <thead> <tr> <th>PIN No.</th> <th>Signal</th> </tr> </thead> <tbody> <tr> <td>1</td> <td>BK+</td> </tr> <tr> <td>2</td> <td>BK-</td> </tr> </tbody> </table> <p>MS3108B14S-7S (2Circuits)</p> <p>1. Motor Side Connector (MS: Military Standard) • PLUG Spec: MS3108A 14S-7S</p> <p>2. Drive Side Connector • Connecting Terminal Spec.: 1.5x3 (Ring Terminal)</p> <p>3. Cable Spec.: 2Cx0.75SQ or 2Cx18AWG</p>	PIN No.	Signal	1	BK+	2	BK-						
PIN No.	Signal																
1	BK+																
2	BK-																
Encoder Battery	Battery for ABS	APCS-BATT36	All Model of L7 Series iX7NHA□□□□U iX7M-A-□□□□B	All Model of F Series All Model of E Series	 <table border="1"> <thead> <tr> <th>PIN No.</th> <th>Signal</th> </tr> </thead> <tbody> <tr> <td>1</td> <td>BK+</td> </tr> <tr> <td>2</td> <td>BK-</td> </tr> </tbody> </table> <p>• PLUG Spec: 5264-02 (Molex) • PLUG Pin Spec.: 5263PBT (Molex) • Battery Spec: ER6V/3.6V, 2000mAh (TOSHIBA)</p>	PIN No.	Signal	1	BK+	2	BK-						
PIN No.	Signal																
1	BK+																
2	BK-																

Note1 The three blank squares in model names indicate the type and length of cables. And the designation is as below.

Cable Length(m)	1	2	3	...	18	19	20
General Cable	N01	N02	N03	...	N18	N19	N20
Robotic Cable	F01	F02	F03	...	F18	F19	F20

Note2 The three blank squares in model names indicate drive capacity. For details regarding the designation, please refer to pages 16 / 22 / 28 / 38 / 44 / 54 / 58 / 66 / 72page

Signal Cable E Series Motor

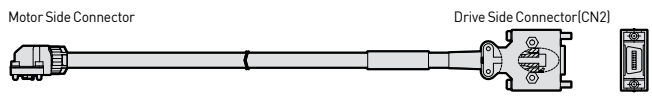
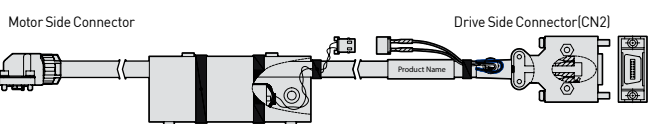
Type	Product Type	Model Name ^{Note1}	Applicable Drive ^{Note2}	Applicable Motor	Specifications																																												
For Power	E Series Motor S-turn Encoder Cable (Small Capacity)	APCS- E□□□ RS-□	L7SA□□□B L7NHA□□□U L7PA□□□U L7CA□□□U iX7NHA□□□U	All Model of EA EB EC SERIES	 <table border="1"> <thead> <tr> <th>PIN No.</th> <th>Encoder Signal</th> <th>PIN No.</th> <th>Encoder Signal</th> </tr> </thead> <tbody> <tr> <td>1</td> <td>SHIELD</td> <td>8</td> <td>-</td> </tr> <tr> <td>2</td> <td>SLO</td> <td>9</td> <td>-</td> </tr> <tr> <td>3</td> <td>SLO</td> <td>10</td> <td>-</td> </tr> <tr> <td>4</td> <td>MA</td> <td>11</td> <td>-</td> </tr> <tr> <td>5</td> <td>MA</td> <td>12</td> <td>-</td> </tr> <tr> <td>6</td> <td>-</td> <td>13</td> <td>-</td> </tr> <tr> <td>7</td> <td>-</td> <td>14</td> <td>+5V</td> </tr> <tr> <td colspan="2">PLATE</td> <td colspan="2">SHIELD</td> </tr> </tbody> </table> <p>(Motor Side Connector) (Drive Side Connector)</p> <p>1. Motor Side Connector</p> <ul style="list-style-type: none"> • Cap Spec.: SJ117363(Front, JAE), SJ121270(Rear, JAE) • Socket Spec.: JN-24S-C1B-10000(JAE) <p>2. Drive Side Connector(CN2)</p> <ul style="list-style-type: none"> • Cable Spec.: 10314-52A0-008(3M) or SM-14J(Suntone) • Connector Spec.: 10114-3000VE(3M) or SM-14J(Suntone) • Cable Spec.: 3P×0.25Q or 3P×24AWG 	PIN No.	Encoder Signal	PIN No.	Encoder Signal	1	SHIELD	8	-	2	SLO	9	-	3	SLO	10	-	4	MA	11	-	5	MA	12	-	6	-	13	-	7	-	14	+5V	PLATE		SHIELD									
	PIN No.				Encoder Signal	PIN No.	Encoder Signal																																										
1	SHIELD	8	-																																														
2	SLO	9	-																																														
3	SLO	10	-																																														
4	MA	11	-																																														
5	MA	12	-																																														
6	-	13	-																																														
7	-	14	+5V																																														
PLATE		SHIELD																																															
For Power	E Series Motor M-turn Encoder Cable (Small Capacity)	APCS- E□□□ RS1-□	L7SA□□□B L7NHA□□□U L7PA□□□U L7CA□□□U iX7NHA□□□U	All Model of EA EB EC SERIES	 <table border="1"> <thead> <tr> <th>PIN No.</th> <th>Encoder Signal</th> <th>PIN No.</th> <th>Encoder Signal</th> </tr> </thead> <tbody> <tr> <td>1</td> <td>SHIELD</td> <td>8</td> <td>-</td> </tr> <tr> <td>2</td> <td>SLO</td> <td>9</td> <td>-</td> </tr> <tr> <td>3</td> <td>SLO</td> <td>10</td> <td>-</td> </tr> <tr> <td>4</td> <td>MA</td> <td>11</td> <td>-</td> </tr> <tr> <td>5</td> <td>MA</td> <td>12</td> <td>-</td> </tr> <tr> <td>6</td> <td>GND_B</td> <td>13</td> <td>-</td> </tr> <tr> <td>7</td> <td>VOD_B</td> <td>14</td> <td>+5V</td> </tr> <tr> <td>8</td> <td>OV</td> <td></td> <td></td> </tr> <tr> <td>9</td> <td>+5V</td> <td></td> <td></td> </tr> <tr> <td colspan="2">PLATE</td> <td colspan="2">SHIELD</td> </tr> </tbody> </table> <p>(Motor Side Connector) (Drive Side Connector)</p> <p>1. Motor Side Connector</p> <ul style="list-style-type: none"> • Cap Spec.: SJ117363(Front, JAE), SJ121270(Rear, JAE) • Socket Spec.: JN-24S-C1B-10000(JAE) <p>2. Drive Side Connector(CN2)</p> <ul style="list-style-type: none"> • Cable Spec.: 10314-52A0-008(3M) or SM-14J(Suntone) • Connector Spec.: 10114-3000VE(3M) or SM-14J(Suntone) • Cable Spec.: 4P×0.25Q or 4P×24AWG • BATTERY CONNECTOR Spec.: 5267-02A(MOLEX) 	PIN No.	Encoder Signal	PIN No.	Encoder Signal	1	SHIELD	8	-	2	SLO	9	-	3	SLO	10	-	4	MA	11	-	5	MA	12	-	6	GND_B	13	-	7	VOD_B	14	+5V	8	OV			9	+5V			PLATE		SHIELD	
PIN No.	Encoder Signal	PIN No.	Encoder Signal																																														
1	SHIELD	8	-																																														
2	SLO	9	-																																														
3	SLO	10	-																																														
4	MA	11	-																																														
5	MA	12	-																																														
6	GND_B	13	-																																														
7	VOD_B	14	+5V																																														
8	OV																																																
9	+5V																																																
PLATE		SHIELD																																															

Note1 The three blank squares in model names indicate the type and length of cables. And the designation is as below.

Note2 In case a model name contains a single blank square, the connector can draw towards both front(load) and rear(half-load). (Front Type: no markings, Rear Type: marked -R)

Cable Length(m)	1	2	3	...	18	19	20
General Cable	N01	N02	N03	...	N18	N19	N20
Robotic Cable	F01	F02	F03	...	F18	F19	F20

Note2 The three blank squares in model names indicate drive capacity. For details regarding the designation, please refer to pages 16 / 22 / 28 / 38 / 44 / 54 / 58 / 66 / 72page

Signal Cable E Series Motor

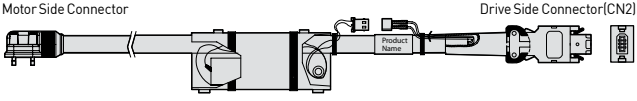
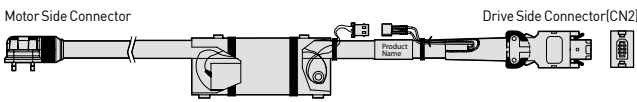
Type	Product Type	Model Name <small>Note1)</small>	Applicable Drive <small>Note2)</small>	Applicable Motor	Specifications																																									
For Power	E Series Motor S-turn Encoder Cable (Small Capacity)	APCS-E□□□ RM-□	iX7M-A-□□□□B	All Model of EA EB EC SERIES	 <div style="display: flex; justify-content: space-around;"> <table border="1" style="font-size: 8px;"> <thead> <tr><th>PIN No.</th><th>Encoder Signal</th></tr> </thead> <tbody> <tr><td>1</td><td>SHIELD</td></tr> <tr><td>2</td><td>SLO</td></tr> <tr><td>3</td><td>SLO</td></tr> <tr><td>4</td><td>MA</td></tr> <tr><td>5</td><td>MA</td></tr> <tr><td>6</td><td>-</td></tr> <tr><td>7</td><td>-</td></tr> <tr><td>8</td><td>OV</td></tr> <tr><td>9</td><td>+5V</td></tr> </tbody> </table> <table border="1" style="font-size: 8px;"> <thead> <tr><th>PIN No.</th><th>Encoder Signal</th><th>PIN No.</th><th>Encoder Signal</th></tr> </thead> <tbody> <tr><td>1</td><td>+5V</td><td>5</td><td>MA</td></tr> <tr><td>2</td><td>OV</td><td>6</td><td>MA</td></tr> <tr><td>3</td><td>SLO</td><td>Plate</td><td>SHIELD</td></tr> <tr><td>4</td><td>SLO</td><td></td><td></td></tr> </tbody> </table> </div> <p>(Motor Side Connector)</p> <p>1. Motor Side Connector</p> <ul style="list-style-type: none"> • Cap Spec.: SJ117363(Front, JAE), SJ121270(Rear, JAE) • Socket Spec.: JN-24S-C1B-10000(JAE) <p>2. Drive Side Connector(CN2)</p> <ul style="list-style-type: none"> • Cable Spec.: SC-06B-2N00-702(Sunchu) • Connector Spec.: SC-06B-2N00-702(Sunchu) • Cable Spec.: 3P×0.25Q or 3P×24AWG 	PIN No.	Encoder Signal	1	SHIELD	2	SLO	3	SLO	4	MA	5	MA	6	-	7	-	8	OV	9	+5V	PIN No.	Encoder Signal	PIN No.	Encoder Signal	1	+5V	5	MA	2	OV	6	MA	3	SLO	Plate	SHIELD	4	SLO			
	PIN No.	Encoder Signal																																												
1	SHIELD																																													
2	SLO																																													
3	SLO																																													
4	MA																																													
5	MA																																													
6	-																																													
7	-																																													
8	OV																																													
9	+5V																																													
PIN No.	Encoder Signal	PIN No.	Encoder Signal																																											
1	+5V	5	MA																																											
2	OV	6	MA																																											
3	SLO	Plate	SHIELD																																											
4	SLO																																													
E Series Motor M-turn Encoder Cable (Small Capacity)	APCS-E□□□ RM1-□	iX7M-A-□□□□B	All Model of EA EB EC SERIES	 <div style="display: flex; justify-content: space-around;"> <table border="1" style="font-size: 8px;"> <thead> <tr><th>PIN No.</th><th>Encoder Signal</th></tr> </thead> <tbody> <tr><td>1</td><td>SHIELD</td></tr> <tr><td>2</td><td>SLO</td></tr> <tr><td>3</td><td>SLO</td></tr> <tr><td>4</td><td>MA</td></tr> <tr><td>5</td><td>MA</td></tr> <tr><td>6</td><td>GND_B</td></tr> <tr><td>7</td><td>VOD_B</td></tr> <tr><td>8</td><td>OV</td></tr> <tr><td>9</td><td>+5V</td></tr> </tbody> </table> <table border="1" style="font-size: 8px;"> <thead> <tr><th>PIN No.</th><th>Encoder Signal</th></tr> </thead> <tbody> <tr><td>1</td><td>+5V</td></tr> <tr><td>2</td><td>OV</td></tr> <tr><td>3</td><td>SLO</td></tr> <tr><td>4</td><td>SLO</td></tr> <tr><td>5</td><td>MA</td></tr> <tr><td>6</td><td>MA</td></tr> <tr><td>Plate</td><td>SHIELD</td></tr> </tbody> </table> <table border="1" style="font-size: 8px;"> <thead> <tr><th>PIN No.</th><th>Encoder Signal</th></tr> </thead> <tbody> <tr><td>1</td><td>BATTERY (VDD_B)</td></tr> <tr><td>2</td><td>BATTERY OV (GND_B)</td></tr> </tbody> </table> </div> <p>(Motor Side Connector)</p> <p>1. Motor Side Connector</p> <ul style="list-style-type: none"> • Cap Spec.: SJ117363(Front, JAE), SJ121270(Rear, JAE) • Socket Spec.: JN-24S-C1B-10000(JAE) <p>2. Drive Side Connector(CN2)</p> <ul style="list-style-type: none"> • Cable Spec.: SC-06B-2N00-702(Sunchu) • Connector Spec.: SC-06B-2N00-702(Sunchu) • Cable Spec.: 4P×0.25Q or 4P×24AWG • BATTERY CONNECTOR Spec.: 5267-02A(MOLEX) 	PIN No.	Encoder Signal	1	SHIELD	2	SLO	3	SLO	4	MA	5	MA	6	GND_B	7	VOD_B	8	OV	9	+5V	PIN No.	Encoder Signal	1	+5V	2	OV	3	SLO	4	SLO	5	MA	6	MA	Plate	SHIELD	PIN No.	Encoder Signal	1	BATTERY (VDD_B)	2	BATTERY OV (GND_B)
PIN No.	Encoder Signal																																													
1	SHIELD																																													
2	SLO																																													
3	SLO																																													
4	MA																																													
5	MA																																													
6	GND_B																																													
7	VOD_B																																													
8	OV																																													
9	+5V																																													
PIN No.	Encoder Signal																																													
1	+5V																																													
2	OV																																													
3	SLO																																													
4	SLO																																													
5	MA																																													
6	MA																																													
Plate	SHIELD																																													
PIN No.	Encoder Signal																																													
1	BATTERY (VDD_B)																																													
2	BATTERY OV (GND_B)																																													

Note1) The three blank squares in model names indicate the type and length of cables. And the designation is as below.

Cable Length(m)	1	2	3	...	18	19	20
General Cable	N01	N02	N03	...	N18	N19	N20
Robotic Cable	F01	F02	F03	...	F18	F19	F20

Note2) The three blank squares in model names indicate drive capacity. For details regarding the designation, please refer to pages 16 / 22 / 28 / 38 / 44 / 54 / 58 / 66 / 72page

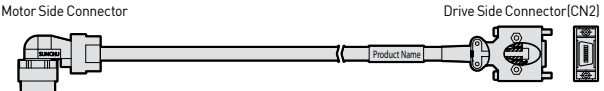
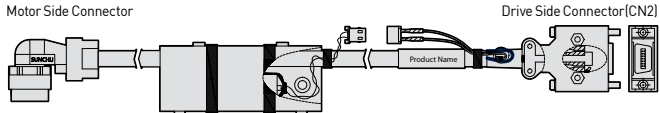
Type	Product Type	Model Name ^{Note1)}	Applicable Drive ^{Note2)}	Applicable Motor	Specifications																																																															
For Power	E Series batteryless For encoder-applied motors M-turn Encoder Cable (Small Capacity)	APCS-E □□□SC	L7SA□□□B L7NHA□□□U L7PA□□□U IX7NHA□□□U	All Model of EE EF Series	 <table border="1" data-bbox="869 548 1045 705"> <thead> <tr> <th>PIN No.</th> <th>Encoder Signal</th> <th>PIN No.</th> <th>Encoder Signal</th> </tr> </thead> <tbody> <tr><td>1</td><td>+5V</td><td>6</td><td>MA</td></tr> <tr><td>2</td><td>0V</td><td>7</td><td>MA</td></tr> <tr><td>3</td><td>-</td><td>8</td><td>SLO</td></tr> <tr><td>4</td><td>VOD_B</td><td>9</td><td>SLO</td></tr> <tr><td>5</td><td>GND_B</td><td>10</td><td>SHIELD</td></tr> </tbody> </table> <p>(Motor Side Connector)</p> <table border="1" data-bbox="1125 548 1348 772"> <thead> <tr> <th>PIN No.</th> <th>Encoder Signal</th> <th>PIN No.</th> <th>Encoder Signal</th> </tr> </thead> <tbody> <tr><td>1</td><td>-</td><td>8</td><td>-</td></tr> <tr><td>2</td><td>-</td><td>9</td><td>-</td></tr> <tr><td>3</td><td>MA</td><td>10</td><td>-</td></tr> <tr><td>4</td><td>MA</td><td>11</td><td>-</td></tr> <tr><td>5</td><td>SLO</td><td>12</td><td>-</td></tr> <tr><td>6</td><td>SLO</td><td>13</td><td>-</td></tr> <tr><td>7</td><td>OV</td><td>14</td><td>+5V</td></tr> <tr><td colspan="2">PLATE</td><td colspan="2">SHIELD</td></tr> </tbody> </table> <p>(Drive Side Connector)</p> <p>1. Motor Side Connector(Sunchu) • Plug Spec.: SC-CMV1-AP10C</p> <p>2. Drive Side Connector(CN2) • Cable Spec.: 10314-52A0-008(3M) or SM-14J(Suntone)</p> <p>• Connector Spec.: 10114-3000VE(3M) or SM-14J(Suntone) • Cable Spec.: 4P×0.25Q or 4P×24AWG</p>	PIN No.	Encoder Signal	PIN No.	Encoder Signal	1	+5V	6	MA	2	0V	7	MA	3	-	8	SLO	4	VOD_B	9	SLO	5	GND_B	10	SHIELD	PIN No.	Encoder Signal	PIN No.	Encoder Signal	1	-	8	-	2	-	9	-	3	MA	10	-	4	MA	11	-	5	SLO	12	-	6	SLO	13	-	7	OV	14	+5V	PLATE		SHIELD				
	PIN No.	Encoder Signal	PIN No.	Encoder Signal																																																																
1	+5V	6	MA																																																																	
2	0V	7	MA																																																																	
3	-	8	SLO																																																																	
4	VOD_B	9	SLO																																																																	
5	GND_B	10	SHIELD																																																																	
PIN No.	Encoder Signal	PIN No.	Encoder Signal																																																																	
1	-	8	-																																																																	
2	-	9	-																																																																	
3	MA	10	-																																																																	
4	MA	11	-																																																																	
5	SLO	12	-																																																																	
6	SLO	13	-																																																																	
7	OV	14	+5V																																																																	
PLATE		SHIELD																																																																		
E Series Motor M-turn Encoder Cable (Medium to large capacity)	APCS-E □□□SC1	L7SA□□□B L7NHA□□□U L7PA□□□U IX7NHA□□□U	All Model of EE EF Series	 <table border="1" data-bbox="829 1030 941 1299"> <thead> <tr> <th>PIN No.</th> <th>Encoder Signal</th> </tr> </thead> <tbody> <tr><td>1</td><td>+5V</td></tr> <tr><td>2</td><td>0V</td></tr> <tr><td>3</td><td>-</td></tr> <tr><td>4</td><td>VOD_B</td></tr> <tr><td>5</td><td>GND_B</td></tr> <tr><td>6</td><td>MA</td></tr> <tr><td>7</td><td>MA</td></tr> <tr><td>8</td><td>SLO</td></tr> <tr><td>9</td><td>SLO</td></tr> <tr><td>10</td><td>SHIELD</td></tr> </tbody> </table> <p>(Motor Side Connector)</p> <table border="1" data-bbox="1029 1030 1244 1254"> <thead> <tr> <th>PIN No.</th> <th>Encoder Signal</th> <th>PIN No.</th> <th>Encoder Signal</th> </tr> </thead> <tbody> <tr><td>1</td><td>-</td><td>8</td><td>-</td></tr> <tr><td>2</td><td>-</td><td>9</td><td>-</td></tr> <tr><td>3</td><td>MA</td><td>10</td><td>-</td></tr> <tr><td>4</td><td>MA</td><td>11</td><td>-</td></tr> <tr><td>5</td><td>SLO</td><td>12</td><td>-</td></tr> <tr><td>6</td><td>SLO</td><td>13</td><td>-</td></tr> <tr><td>7</td><td>OV</td><td>14</td><td>+5V</td></tr> <tr><td colspan="2">PLATE</td><td colspan="2">SHIELD</td></tr> </tbody> </table> <p>(Drive Side Connector)</p> <table border="1" data-bbox="1276 1030 1396 1243"> <thead> <tr> <th>PIN No.</th> <th>Encoder Signal</th> </tr> </thead> <tbody> <tr><td>1</td><td>BATTERY (VDD_B)</td></tr> <tr><td>2</td><td>BATTERY OV (GND_B)</td></tr> </tbody> </table> <p>(Battery Connector)</p> <p>1. Motor Side Connector(Sunchu) • Plug Spec.: SC-CMV1-AP10C</p> <p>2. Drive Side Connector(CN2) • Cable Spec.: 10314-52A0-008(3M) or SM-14J(Suntone)</p> <p>• Connector Spec.: 10114-3000VE(3M) or SM-14J(Suntone) • Cable Spec.: 4P×0.25Q or 4P×24AWG • BATTERY CONNECTOR Spec.: 5267-02A(MOLEX)</p>	PIN No.	Encoder Signal	1	+5V	2	0V	3	-	4	VOD_B	5	GND_B	6	MA	7	MA	8	SLO	9	SLO	10	SHIELD	PIN No.	Encoder Signal	PIN No.	Encoder Signal	1	-	8	-	2	-	9	-	3	MA	10	-	4	MA	11	-	5	SLO	12	-	6	SLO	13	-	7	OV	14	+5V	PLATE		SHIELD		PIN No.	Encoder Signal	1	BATTERY (VDD_B)	2	BATTERY OV (GND_B)
PIN No.	Encoder Signal																																																																			
1	+5V																																																																			
2	0V																																																																			
3	-																																																																			
4	VOD_B																																																																			
5	GND_B																																																																			
6	MA																																																																			
7	MA																																																																			
8	SLO																																																																			
9	SLO																																																																			
10	SHIELD																																																																			
PIN No.	Encoder Signal	PIN No.	Encoder Signal																																																																	
1	-	8	-																																																																	
2	-	9	-																																																																	
3	MA	10	-																																																																	
4	MA	11	-																																																																	
5	SLO	12	-																																																																	
6	SLO	13	-																																																																	
7	OV	14	+5V																																																																	
PLATE		SHIELD																																																																		
PIN No.	Encoder Signal																																																																			
1	BATTERY (VDD_B)																																																																			
2	BATTERY OV (GND_B)																																																																			

Note1) The three blank squares in model names indicate the type and length of cables. And the designation is as below.

Cable Length(m)	1	2	3	...	18	19	20
General Cable	N01	N02	N03	...	N18	N19	N20
Robotic Cable	F01	F02	F03	...	F18	F19	F20

Note2) The three blank squares in model names indicate drive capacity. For details regarding the designation, please refer to pages 16 / 22 / 28 / 38 / 44 / 54 / 58 / 66 / 72page

Power Cable E Series Motor (iX7NH, iX7M)

Type	Product Type	Model Name ^{Note1)}	Applicable Drive ^{Note2)}	Applicable Motor	Specifications										
For Power	Power Cable E Series	APCS-P□□□ EX1-□	iX7NHA□□□U iX7M-A-□□□□B	All Model of iX7NH applied EA Series	 <table border="1" data-bbox="1125 1892 1332 2016"> <thead> <tr> <th>PIN 번호</th> <th>신호</th> </tr> </thead> <tbody> <tr><td>1</td><td>FG</td></tr> <tr><td>2</td><td>W</td></tr> <tr><td>3</td><td>V</td></tr> <tr><td>4</td><td>U</td></tr> </tbody> </table> <p>Front Direction Rear Direction</p> <p>1. Motor Side Connector • CAP Spec.: SC-MC6S-AK20-00(Sunchu) • Socket Spec.: FMC19012220(Sunchu)</p> <p>2. Drive Side Connector • U, V, W, FG pin Spec.: 0208(002508) or 0308 • Cable Spec.: 6C×0.25Q or 6C×24(25)AWG</p>	PIN 번호	신호	1	FG	2	W	3	V	4	U
PIN 번호	신호														
1	FG														
2	W														
3	V														
4	U														

Power Cable E Series Motor (iX7NH, iX7M)

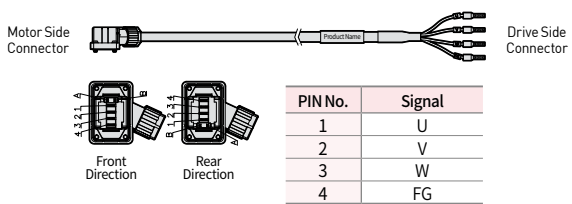
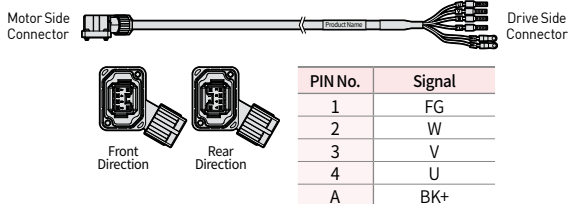
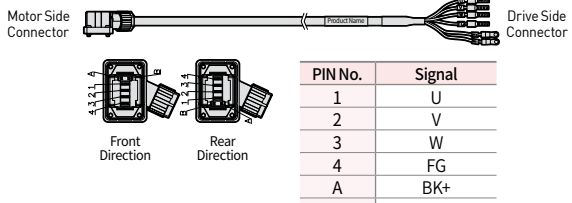
Type	Product Type	Model Name ^{Note1)}	Applicable Drive ^{Note2)}	Applicable Motor	Specifications														
For Power	Power Cable E Series	APCS-P□□□EX-□	iX7NHA□□□□U iX7M-A-□□□□B	All Model of iX7NH applied EB EC Series	 <table border="1" data-bbox="1077 515 1284 638"> <thead> <tr> <th>PIN No.</th> <th>Signal</th> </tr> </thead> <tbody> <tr><td>1</td><td>U</td></tr> <tr><td>2</td><td>V</td></tr> <tr><td>3</td><td>W</td></tr> <tr><td>4</td><td>FG</td></tr> </tbody> </table> <p>1. Motor Side Connector</p> <ul style="list-style-type: none"> Cap Spec.: SC-MC6S-AJ20-00(Sunchu) Socket Spec.: FMC2201220(Sunchu) <p>2. Drive Side Connector</p> <ul style="list-style-type: none"> U, V, W, FG Pin Spec.: 007508 or 0708 Cable Spec.: 4C×0.55SQ(20AWG) + 2C×0.25SQ(24AWG) or 4C×0.75SQ(18AWG)+2CX0.125SQ(26AWG) 	PIN No.	Signal	1	U	2	V	3	W	4	FG				
PIN No.	Signal																		
1	U																		
2	V																		
3	W																		
4	FG																		
For Power	Power Cable E Series (Brake Type)	APCS-P□□□EBX1-□	iX7NHA□□□□U iX7M-A-□□□□B	All Model of iX7NH applied EA Series	 <table border="1" data-bbox="1077 940 1284 1108"> <thead> <tr> <th>PIN No.</th> <th>Signal</th> </tr> </thead> <tbody> <tr><td>1</td><td>FG</td></tr> <tr><td>2</td><td>W</td></tr> <tr><td>3</td><td>V</td></tr> <tr><td>4</td><td>U</td></tr> <tr><td>A</td><td>BK+</td></tr> <tr><td>B</td><td>BK-</td></tr> </tbody> </table> <p>1. Motor Side Connector</p> <ul style="list-style-type: none"> Cap Spec.: SC-MC6S-AJ20-00(Sunchu) Socket Spec.: FMC2201220(Sunchu) <p>2. Drive Side Connector</p> <ul style="list-style-type: none"> U, V, W, FG Pin Spec.: 0208(002508) or 0308 Cable Spec.: 6C×0.25Q or 6C×24(25AWG) <p>3. Brake Power Side Connector</p> <ul style="list-style-type: none"> BKPin Spec.: 1.5×3(Ring Terminal) 	PIN No.	Signal	1	FG	2	W	3	V	4	U	A	BK+	B	BK-
PIN No.	Signal																		
1	FG																		
2	W																		
3	V																		
4	U																		
A	BK+																		
B	BK-																		
For Power	Power Cable E Series (Brake Type)	APCS-P□□□EBX-□	iX7NHA□□□□U iX7M-A-□□□□B	All Model of iX7NH applied EB EC Series	 <table border="1" data-bbox="1077 1456 1284 1624"> <thead> <tr> <th>PIN No.</th> <th>Signal</th> </tr> </thead> <tbody> <tr><td>1</td><td>U</td></tr> <tr><td>2</td><td>V</td></tr> <tr><td>3</td><td>W</td></tr> <tr><td>4</td><td>FG</td></tr> <tr><td>A</td><td>BK+</td></tr> <tr><td>B</td><td>BK-</td></tr> </tbody> </table> <p>1. Motor Side Connector</p> <ul style="list-style-type: none"> Cap Spec.: SC-MC6S-AJ20-00(Sunchu) Socket Spec.: FMC2201220, FMC1901220 (Sunchu) <p>2. Drive Side Connector</p> <ul style="list-style-type: none"> U, V, W, FG Pin Spec.: 007508 or 0708 Cable Spec.: 4C×0.55SQ(20AWG) + 2C×0.25SQ(24AWG) or 4C×0.75SQ(18AWG)+2CX0.125SQ(26AWG) <p>3. Brake Power Side Connector</p> <ul style="list-style-type: none"> BKPin Spec.: 1.5×3(Ring Terminal) 	PIN No.	Signal	1	U	2	V	3	W	4	FG	A	BK+	B	BK-
PIN No.	Signal																		
1	U																		
2	V																		
3	W																		
4	FG																		
A	BK+																		
B	BK-																		

Note1) The three blank squares in model names indicate the type and length of cables. And the designation is as below.

Cable Length(m)	1	2	3	...	18	19	20
General Cable	N01	N02	N03	...	N18	N19	N20
Robotic Cable	F01	F02	F03	...	F18	F19	F20

Note2) The three blank squares in model names indicate drive capacity. For details regarding the designation, please refer to pages 16 / 22 / 28 / 38 / 44 / 54 / 58 / 66 / 72page

Note3) In case of □40 50W, □60 100W, pay attention to the power connector protrusion when applying to the front.

Power Cable E Series Motor (iX7NH)

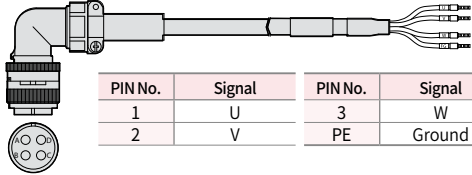
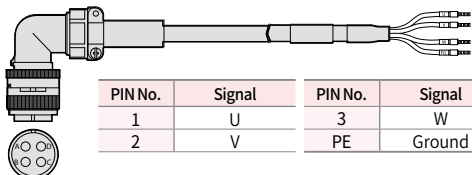
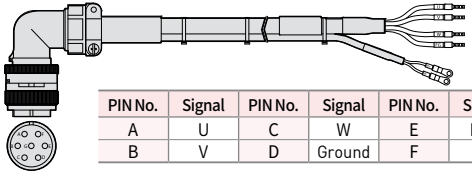
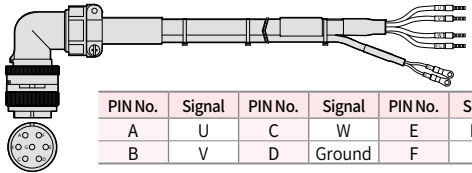
Type	Product Type	Model Name ^{Note1)}	Applicable Drive ^{Note2)}	Applicable Motor	Specifications																		
For Power	Power Cable E Series (iX7NH)	APCS-P □□□HSX1	iX7NHA□□□□U	iX7NH applied EE Series EE09A/EE15A EE06D/EE11D EE03M/EE06M EE09M	 <table border="1" data-bbox="938 515 1343 593"> <thead> <tr> <th>PIN No.</th> <th>Signal</th> <th>PIN No.</th> <th>Signal</th> </tr> </thead> <tbody> <tr> <td>1</td> <td>U</td> <td>3</td> <td>W</td> </tr> <tr> <td>2</td> <td>V</td> <td>PE</td> <td>Ground</td> </tr> </tbody> </table> <p>1. Motor Side Connector (MS: Military Standard) • Plug Spec.: MS 3108A 20-4S</p> <p>2. Drive Side Connector • U, V, W, Pin Spec.: F1508 • Cable Spec.: 4Cx1.5SQ or 4Cx15AWG • FG Pin Spec.: F1508</p> <p>※ Specifications are subject to change without notice.</p>	PIN No.	Signal	PIN No.	Signal	1	U	3	W	2	V	PE	Ground						
PIN No.	Signal	PIN No.	Signal																				
1	U	3	W																				
2	V	PE	Ground																				
For Power	Power Cable E Series (iX7NH)	APCS-P □□□HSX	iX7NHA□□□□U	iX7NH applied EE Series EE22A/EE30A EE16D/EE22D EE12M	 <table border="1" data-bbox="938 880 1343 958"> <thead> <tr> <th>PIN No.</th> <th>Signal</th> <th>PIN No.</th> <th>Signal</th> </tr> </thead> <tbody> <tr> <td>1</td> <td>U</td> <td>3</td> <td>W</td> </tr> <tr> <td>2</td> <td>V</td> <td>PE</td> <td>Ground</td> </tr> </tbody> </table> <p>1. Motor Side Connector (MS: Military Standard) • Plug Spec.: MS 3108A 20-4S</p> <p>2. Drive Side Connector • U, V, W, Pin Spec.: F2508 • Cable Spec.: 4Cx2.5SQ or 4Cx14AWG • FG Pin Spec.: F2508</p> <p>※ Specifications are subject to change without notice.</p>	PIN No.	Signal	PIN No.	Signal	1	U	3	W	2	V	PE	Ground						
PIN No.	Signal	PIN No.	Signal																				
1	U	3	W																				
2	V	PE	Ground																				
For Power	Power Cable E Series (iX7NH)	APCS-P □□□NBX1	iX7NHA□□□□U	iX7NH applied EE Series EE09A/EE15A EE06D/EE11D EE03M/EE06M EE09M	 <table border="1" data-bbox="938 1249 1359 1328"> <thead> <tr> <th>PIN No.</th> <th>Signal</th> <th>PIN No.</th> <th>Signal</th> <th>PIN No.</th> <th>Signal</th> </tr> </thead> <tbody> <tr> <td>A</td> <td>U</td> <td>C</td> <td>W</td> <td>E</td> <td>BK+</td> </tr> <tr> <td>B</td> <td>V</td> <td>D</td> <td>Ground</td> <td>F</td> <td>BK-</td> </tr> </tbody> </table> <p>1. Motor Side Connector (MS: Military Standard) • Plug Spec.: MS 3108A 20-15S</p> <p>2. Drive Side Connector • U, V, W, Pin Spec.: F1508 • Cable Spec.: 4Cx1.5SQ or 4Cx15AWG • FG Pin Spec.: F1508</p> <p>3. Brake Side Connector • BK Pin Spec.: 1.5x3(Ring Terminal) • Cable Spec.: 2Cx0.75SQ or 2Cx18AWG</p> <p>※ Specifications are subject to change without notice.</p>	PIN No.	Signal	PIN No.	Signal	PIN No.	Signal	A	U	C	W	E	BK+	B	V	D	Ground	F	BK-
PIN No.	Signal	PIN No.	Signal	PIN No.	Signal																		
A	U	C	W	E	BK+																		
B	V	D	Ground	F	BK-																		
For Power	Power Cable E Series (iX7NH)	APCS-P □□□NBX	iX7NHA□□□□U	iX7NH applied EE Series EE22A/EE30A EE16D/EE22D EE12M	 <table border="1" data-bbox="938 1630 1359 1709"> <thead> <tr> <th>PIN No.</th> <th>Signal</th> <th>PIN No.</th> <th>Signal</th> <th>PIN No.</th> <th>Signal</th> </tr> </thead> <tbody> <tr> <td>A</td> <td>U</td> <td>C</td> <td>W</td> <td>E</td> <td>BK+</td> </tr> <tr> <td>B</td> <td>V</td> <td>D</td> <td>Ground</td> <td>F</td> <td>BK-</td> </tr> </tbody> </table> <p>1. Motor Side Connector (MS: Military Standard) • Plug Spec.: MS 3108A 20-15S</p> <p>2. Drive Side Connector • U, V, W, Pin Spec.: F2508 • Cable Spec.: 4Cx2.5SQ or 4Cx14AWG • FG Pin Spec.: F2508</p> <p>3. Brake Side Connector • BK Pin Spec.: 1.5x3(Ring Terminal) • Cable Spec.: 2Cx0.75SQ or 2Cx18AWG</p> <p>※ Specifications are subject to change without notice.</p>	PIN No.	Signal	PIN No.	Signal	PIN No.	Signal	A	U	C	W	E	BK+	B	V	D	Ground	F	BK-
PIN No.	Signal	PIN No.	Signal	PIN No.	Signal																		
A	U	C	W	E	BK+																		
B	V	D	Ground	F	BK-																		

^{Note1)} The three blank squares in model names indicate the type and length of cables. And the designation is as below.

Cable Length(m)	1	2	3	...	18	19	20
General Cable	N01	N02	N03	...	N18	N19	N20
Robotic Cable	F01	F02	F03	...	F18	F19	F20

^{Note2)} The three blank squares in model names indicate drive capacity. For details regarding the designation, please refer to pages 16 / 22 / 28 / 38 / 44 / 54 / 58 / 66 / 72 page

Power Cable E Series Motor (iX7NH)

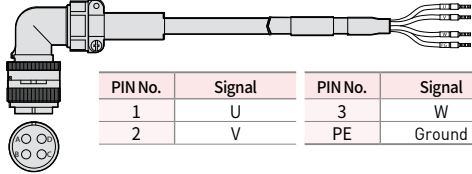
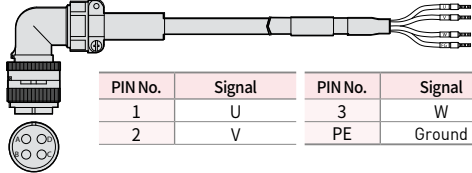
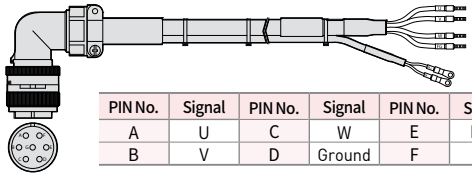
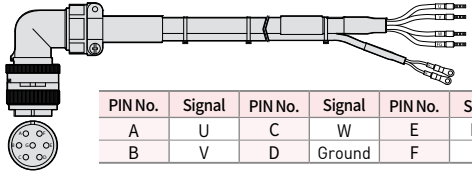
Type	Product Type	Model Name ^{Note1)}	Applicable Drive ^{Note2)}	Applicable Motor	Specifications																		
For Power	Power Cable E Series (iX7NH)	APCS-P □□□ISX	iX7NHA□□□U	iX7NH applied EF Series EF30A/EF30G EF20M	 <table border="1"> <thead> <tr> <th>PIN No.</th> <th>Signal</th> <th>PIN No.</th> <th>Signal</th> </tr> </thead> <tbody> <tr> <td>1</td> <td>U</td> <td>3</td> <td>W</td> </tr> <tr> <td>2</td> <td>V</td> <td>PE</td> <td>Ground</td> </tr> </tbody> </table> <p>1. Motor Side Connector (MS: Military Standard) • Plug Spec.: MS 3108A 22-22S</p> <p>2. Drive Side Connector • U, V, W, Pin Spec.: F2508 • Cable Spec.: 4Cx2.5SQ or 4Cx14AWG • FG Pin Spec.: F2508</p> <p>※ Specifications are subject to change without notice.</p>	PIN No.	Signal	PIN No.	Signal	1	U	3	W	2	V	PE	Ground						
PIN No.	Signal	PIN No.	Signal																				
1	U	3	W																				
2	V	PE	Ground																				
For Power	Power Cable E Series (iX7NH)	APCS-P □□□ISX1	iX7NHA□□□U	iX7NH applied EF Series EF20G/EF12M	 <table border="1"> <thead> <tr> <th>PIN No.</th> <th>Signal</th> <th>PIN No.</th> <th>Signal</th> </tr> </thead> <tbody> <tr> <td>1</td> <td>U</td> <td>3</td> <td>W</td> </tr> <tr> <td>2</td> <td>V</td> <td>PE</td> <td>Ground</td> </tr> </tbody> </table> <p>1. Motor Side Connector (MS: Military Standard) • Plug Spec.: MS 3108A 22-22S</p> <p>2. Drive Side Connector • U, V, W, Pin Spec.: F1508 • Cable Spec.: 4Cx1.5SQ or 4Cx15AWG • FG Pin Spec.: F1508</p> <p>※ Specifications are subject to change without notice.</p>	PIN No.	Signal	PIN No.	Signal	1	U	3	W	2	V	PE	Ground						
PIN No.	Signal	PIN No.	Signal																				
1	U	3	W																				
2	V	PE	Ground																				
For Power	Power Cable E Series (iX7NH)	APCS-P □□□PBX	iX7NHA□□□U	iX7NH applied EF Series EF30A/EF30G EF20M	 <table border="1"> <thead> <tr> <th>PIN No.</th> <th>Signal</th> <th>PIN No.</th> <th>Signal</th> <th>PIN No.</th> <th>Signal</th> </tr> </thead> <tbody> <tr> <td>A</td> <td>U</td> <td>C</td> <td>W</td> <td>E</td> <td>BK+</td> </tr> <tr> <td>B</td> <td>V</td> <td>D</td> <td>Ground</td> <td>F</td> <td>BK-</td> </tr> </tbody> </table> <p>1. Motor Side Connector (MS: Military Standard) • Plug Spec.: MS 3108A 24-10S</p> <p>2. Drive Side Connector • U, V, W, Pin Spec.: F1508 • Cable Spec.: 4Cx1.5SQ or 4Cx15AWG • FG Pin Spec.: F1508</p> <p>3. Brake Power Side Connector • BK Pin Spec.: 1.5x3 (Ring Terminal) • Cable Spec.: 2Cx0.75SQ or 2Cx18AWG</p> <p>※ Specifications are subject to change without notice.</p>	PIN No.	Signal	PIN No.	Signal	PIN No.	Signal	A	U	C	W	E	BK+	B	V	D	Ground	F	BK-
PIN No.	Signal	PIN No.	Signal	PIN No.	Signal																		
A	U	C	W	E	BK+																		
B	V	D	Ground	F	BK-																		
For Power	Power Cable E Series (iX7NH)	APCS-P □□□PBX1	iX7NHA□□□U	iX7NH applied EF Series EF20G/EF12M	 <table border="1"> <thead> <tr> <th>PIN No.</th> <th>Signal</th> <th>PIN No.</th> <th>Signal</th> <th>PIN No.</th> <th>Signal</th> </tr> </thead> <tbody> <tr> <td>A</td> <td>U</td> <td>C</td> <td>W</td> <td>E</td> <td>BK+</td> </tr> <tr> <td>B</td> <td>V</td> <td>D</td> <td>Ground</td> <td>F</td> <td>BK-</td> </tr> </tbody> </table> <p>1. Motor Side Connector (MS: Military Standard) • Plug Spec.: MS 3108A 24-10S</p> <p>2. Drive Side Connector • U, V, W, Pin Spec.: F2508 • Cable Spec.: 4Cx2.5SQ or 4Cx14AWG • FG Pin Spec.: F2508</p> <p>3. Brake Power Side Connector • BK Pin Spec.: 1.5x3 (Ring Terminal) • Cable Spec.: 2Cx0.75SQ or 2Cx18AWG</p> <p>※ Specifications are subject to change without notice.</p>	PIN No.	Signal	PIN No.	Signal	PIN No.	Signal	A	U	C	W	E	BK+	B	V	D	Ground	F	BK-
PIN No.	Signal	PIN No.	Signal	PIN No.	Signal																		
A	U	C	W	E	BK+																		
B	V	D	Ground	F	BK-																		

^{Note1)} The three blank squares in model names indicate the type and length of cables. And the designation is as below.

Cable Length(m)	1	2	3	...	18	19	20
General Cable	N01	N02	N03	...	N18	N19	N20
Robotic Cable	F01	F02	F03	...	F18	F19	F20

^{Note2)} The three blank squares in model names indicate drive capacity. For details regarding the designation, please refer to pages 16 / 22 / 28 / 38 / 44 / 54 / 58 / 66 / 72 page

Power Cable E Series Motor (L7)

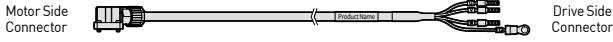
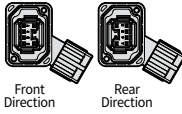
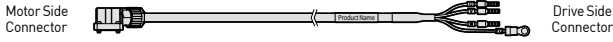
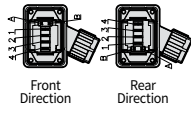
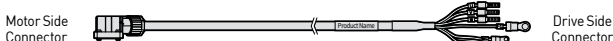
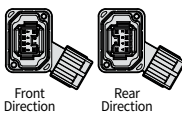
Type	Product Type	Model Name ^{Note1)}	Applicable Drive ^{Note2)}	Applicable Motor	Specifications														
For Power	Power Cable E Series	APCS-P□□□ EL1-□	L7SA□□□□B L7NHA□□□□U L7PA□□□□U	All Model of EA Series	  <table border="1" data-bbox="1102 528 1300 645"> <thead> <tr> <th>PIN No.</th> <th>Signal</th> </tr> </thead> <tbody> <tr> <td>1</td> <td>FG</td> </tr> <tr> <td>2</td> <td>W</td> </tr> <tr> <td>3</td> <td>V</td> </tr> <tr> <td>4</td> <td>U</td> </tr> </tbody> </table> 1. Motor Side Connector <ul style="list-style-type: none"> • Cap Spec.: SC-MC6S-AK20-00(Sunchu) • Socket Spec.: FMC19012220(Sunchu) 2. Drive Side Connector <ul style="list-style-type: none"> • U, V, W, FG Pin Spec.: 1.5×4(Ring Terminal) • Cable Spec.: 6C×0.25SQ or 6C×24(25)AWG 	PIN No.	Signal	1	FG	2	W	3	V	4	U				
PIN No.	Signal																		
1	FG																		
2	W																		
3	V																		
4	U																		
For Power	Power Cable E Series	APCS-P□□□ EL-□	L7SA□□□□B L7NHA□□□□U L7PA□□□□U L7□□□□U	All Model of EB EC Series	  <table border="1" data-bbox="1102 987 1300 1104"> <thead> <tr> <th>PIN No.</th> <th>Signal</th> </tr> </thead> <tbody> <tr> <td>1</td> <td>U</td> </tr> <tr> <td>2</td> <td>V</td> </tr> <tr> <td>3</td> <td>W</td> </tr> <tr> <td>4</td> <td>FG</td> </tr> </tbody> </table> 1. Motor Side Connector <ul style="list-style-type: none"> • Cap Spec.: SC-MC6S-AJ20-00(Sunchu) • Socket Spec.: FMC2201220(Sunchu) 2. Drive Side Connector <ul style="list-style-type: none"> • U, V, W, FG Pin Spec.: 1.5×4(Ring Terminal) • Cable Spec.: 4C×0.55SQ(20AWG) + 2C×0.25SQ(24AWG) or 4C×0.75SQ(18AWG)+2C×0.125SQ(26AWG) 	PIN No.	Signal	1	U	2	V	3	W	4	FG				
PIN No.	Signal																		
1	U																		
2	V																		
3	W																		
4	FG																		
For Power	Power Cable E Series (Brake Type)	APCS-P□□□ EBL1-□	L7SA□□□□B L7NHA□□□□U L7PA□□□□U L7□□□□U	All Model of EA Series	  <table border="1" data-bbox="1102 1435 1300 1608"> <thead> <tr> <th>PIN No.</th> <th>Signal</th> </tr> </thead> <tbody> <tr> <td>1</td> <td>FG</td> </tr> <tr> <td>2</td> <td>W</td> </tr> <tr> <td>3</td> <td>V</td> </tr> <tr> <td>4</td> <td>U</td> </tr> <tr> <td>A</td> <td>BK+</td> </tr> <tr> <td>B</td> <td>BK-</td> </tr> </tbody> </table> 1. Motor Side Connector <ul style="list-style-type: none"> • Cap Spec.: SC-MC6S-AK20-00(Sunchu) • Socket Spec.: FMC19012220(Sunchu) 2. Drive Side Connector <ul style="list-style-type: none"> • U, V, W, Pin Spec.: UA-F0212 or 0312 • Cable Spec.: 6C×0.25SQ or 6C×24(25)AWG 3. Brake Power Side Connector <ul style="list-style-type: none"> • BK Pin Spec.: 1.5×3(Ring Terminal) • FG Pin Spec.: 1.5×4 	PIN No.	Signal	1	FG	2	W	3	V	4	U	A	BK+	B	BK-
PIN No.	Signal																		
1	FG																		
2	W																		
3	V																		
4	U																		
A	BK+																		
B	BK-																		





Note1) The three blank squares in model names indicate the type and length of cables. And the designation is as below.

Cable Length(m)	1	2	3	...	18	19	20
General Cable	N01	N02	N03	...	N18	N19	N20
Robotic Cable	F01	F02	F03	...	F18	F19	F20

Note2) The three blank squares in model names indicate drive capacity. For details regarding the designation, please refer to pages 16 / 22 / 28 / 38 / 44 / 54 / 58 / 66 / 72page

Note3) In case of □40 50W, □60 100W, pay attention to the power connector protrusion when applying to the front.

Power Cable E Series Motor (L7)

Type	Product Type	Model Name ^{Note1)}	Applicable Drive ^{Note2)}	Applicable Motor	Specifications														
For Power	Power Cable E Series (Brake Type)	APCS-P□□□ EBL-□	L7SA□□□B L7NHA□□□U L7PA□□□U L7□□□U	All Model of E B EC Series	<div style="display: flex; justify-content: space-between;"> <div style="text-align: center;">  <p>Motor Side Connector</p> </div> <div style="text-align: center;">  <p>Drive Side Connector</p> </div> </div> <div style="display: flex; justify-content: center; margin-top: 10px;"> <div style="text-align: center; margin-right: 20px;">  <p>Front Direction</p> </div> <div style="text-align: center; margin-right: 20px;">  <p>Rear Direction</p> </div> <table border="1" style="border-collapse: collapse;"> <thead> <tr> <th>PIN No.</th> <th>Signal</th> </tr> </thead> <tbody> <tr><td>1</td><td>U</td></tr> <tr><td>2</td><td>V</td></tr> <tr><td>3</td><td>W</td></tr> <tr><td>4</td><td>FG</td></tr> <tr><td>A</td><td>BK+</td></tr> <tr><td>B</td><td>BK-</td></tr> </tbody> </table> </div> <p style="margin-top: 10px;">1. Motor Side Connector</p> <ul style="list-style-type: none"> • Cap Spec.: SC-MC6S-AJ20-00(Sunchu) • Socket Spec.: FMC2201220, FMC19012220(Sunchu) <p>2. Drive Side Connector</p> <ul style="list-style-type: none"> • U, V, W, Pin Spec.: UA-F0512(or 0712) or CE007512 • Cable Spec.: 4C×0.55SQ(20AWG) + 2C×0.25SQ(24AWG) or 4C×0.75SQ(18AWG)+2CX0.12SQ(26AWG) <p>3. Brake Power Side Connector</p> <ul style="list-style-type: none"> • BK Pin Spec.: 1.5×3(Ring Terminal) • FG Pin Spec.: 1.5×4 	PIN No.	Signal	1	U	2	V	3	W	4	FG	A	BK+	B	BK-
PIN No.	Signal																		
1	U																		
2	V																		
3	W																		
4	FG																		
A	BK+																		
B	BK-																		

Note1) The three blank squares in model names indicate the type and length of cables. And the designation is as below.

Cable Length(m)	1	2	3	...	18	19	20
General Cable	N01	N02	N03	...	N18	N19	N20
Robotic Cable	F01	F02	F03	...	F18	F19	F20

Note2) The three blank squares in model names indicate drive capacity. For details regarding the designation, please refer to pages 16 / 22 / 28 / 38 / 44 / 54 / 58 / 66 / 72page

Note 3) In case of □40 50W, □60 100W, pay attention to the power connector protrusion when applying to the front.

Power Cable E Series Motor (L7C)

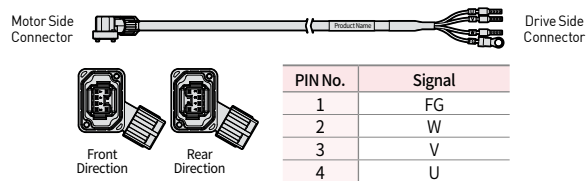
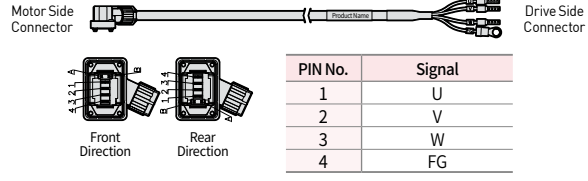
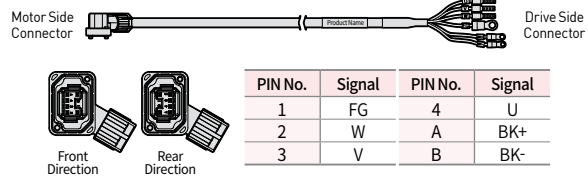
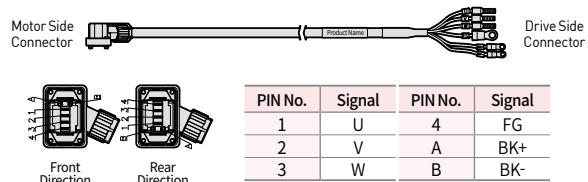
Type	Product Type	Model Name ^{Note1)}	Applicable Drive ^{Note2)}	Applicable Motor	Specifications															
For Power	Power Cable E Series	APCS-P□□□ EC1-□	L7CA□□□U	All Model of EA Series	 <table border="1" data-bbox="1045 504 1276 616"> <thead> <tr> <th>PIN No.</th> <th>Signal</th> </tr> </thead> <tbody> <tr> <td>1</td> <td>FG</td> </tr> <tr> <td>2</td> <td>W</td> </tr> <tr> <td>3</td> <td>V</td> </tr> <tr> <td>4</td> <td>U</td> </tr> </tbody> </table> <p>1. Motor Side Connector</p> <ul style="list-style-type: none"> • Cap Spec.: SC-MC6S-AK20-00(Sunchu) • Socket Spec.: FMC19012220(Sunchu) <p>2. Drive Side Connector</p> <ul style="list-style-type: none"> • U, V, W, FG Pin Spec.: CE002506 or CE005006 • Cable Spec.: 6C×0.25Q or 6C×24(25AWG) 	PIN No.	Signal	1	FG	2	W	3	V	4	U					
		PIN No.	Signal																	
	1	FG																		
	2	W																		
3	V																			
4	U																			
APCS-P□□□ EC-□	L7CA□□□U	All Model of EB EC Series	 <table border="1" data-bbox="1045 828 1276 940"> <thead> <tr> <th>PIN No.</th> <th>Signal</th> </tr> </thead> <tbody> <tr> <td>1</td> <td>U</td> </tr> <tr> <td>2</td> <td>V</td> </tr> <tr> <td>3</td> <td>W</td> </tr> <tr> <td>4</td> <td>FG</td> </tr> </tbody> </table> <p>1. Motor Side Connector</p> <ul style="list-style-type: none"> • Cap Spec.: SC-MC6S-AJ20-00(Sunchu) • Socket Spec.: FMC2201220(Sunchu) <p>2. Drive Side Connector</p> <ul style="list-style-type: none"> • U, V, W, FG Pin Spec.: CE005006 or CE007506 • Cable Spec.: 4C×0.55Q(20AWG) + 2C×0.25Q(24AWG) or 4C×0.75SQ(18AWG)+2C×0.125SQ(26AWG) 	PIN No.	Signal	1	U	2	V	3	W	4	FG							
PIN No.	Signal																			
1	U																			
2	V																			
3	W																			
4	FG																			
Power Cable E Series (Brake Type)	APCS-P□□□ EBC1-□	L7CA□□□U	All Model of E A Series	 <table border="1" data-bbox="1005 1220 1316 1321"> <thead> <tr> <th>PIN No.</th> <th>Signal</th> <th>PIN No.</th> <th>Signal</th> </tr> </thead> <tbody> <tr> <td>1</td> <td>FG</td> <td>4</td> <td>U</td> </tr> <tr> <td>2</td> <td>W</td> <td>A</td> <td>BK+</td> </tr> <tr> <td>3</td> <td>V</td> <td>B</td> <td>BK-</td> </tr> </tbody> </table> <p>1. Motor Side Connector</p> <ul style="list-style-type: none"> • Cap Spec.: SC-MC6S-AK20-00(Sunchu) • Socket Spec.: FMC19012220(Sunchu) <p>2. Drive Side Connector</p> <ul style="list-style-type: none"> • U, V, W, FG Pin Spec.: CE002506 or CE005006 • Cable Spec.: 6C×0.25Q or 6C×24(25AWG) 	PIN No.	Signal	PIN No.	Signal	1	FG	4	U	2	W	A	BK+	3	V	B	BK-
				PIN No.	Signal	PIN No.	Signal													
1	FG	4	U																	
2	W	A	BK+																	
3	V	B	BK-																	
APCS-P□□□ EBC-□	L7CA□□□U	All Model of EB EC Series	 <table border="1" data-bbox="1005 1523 1316 1624"> <thead> <tr> <th>PIN No.</th> <th>Signal</th> <th>PIN No.</th> <th>Signal</th> </tr> </thead> <tbody> <tr> <td>1</td> <td>U</td> <td>4</td> <td>FG</td> </tr> <tr> <td>2</td> <td>V</td> <td>A</td> <td>BK+</td> </tr> <tr> <td>3</td> <td>W</td> <td>B</td> <td>BK-</td> </tr> </tbody> </table> <p>1. Motor Side Connector</p> <ul style="list-style-type: none"> • Cap Spec.: SC-MC6S-AJ20-00(Sunchu) • Socket Spec.: FMC2201220, FMC19012220(Sunchu) <p>2. Drive Side Connector</p> <ul style="list-style-type: none"> • U, V, W, FG Pin Spec.: CE005006 or CE007506 • Cable Spec.: 4C×0.55Q(20AWG) + 2C×0.25Q(24AWG) or 4C×0.75SQ(18AWG)+2C×0.125SQ(26AWG) <p>3. Brake Power Side Connector</p> <ul style="list-style-type: none"> • BK Pin Spec.: 1.5×3(Ring Terminal) • FG Pin Spec.: 1.5×4 	PIN No.	Signal	PIN No.	Signal	1	U	4	FG	2	V	A	BK+	3	W	B	BK-	
PIN No.	Signal	PIN No.	Signal																	
1	U	4	FG																	
2	V	A	BK+																	
3	W	B	BK-																	





Note1) The three blank squares in model names indicate the type and length of cables. And the designation is as below.

Cable Length(m)	1	2	3	...	18	19	20
General Cable	N01	N02	N03	...	N18	N19	N20
Robotic Cable	F01	F02	F03	...	F18	F19	F20

Note2) The three blank squares in model names indicate drive capacity. For details regarding the designation, please refer to pages 16 / 22 / 28 / 38 / 44 / 54 / 58 / 66 / 72page

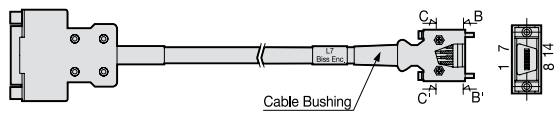
Note3) In case of □40 50W, □60 100W, pay attention to the power connector protrusion when applying to the front.

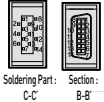
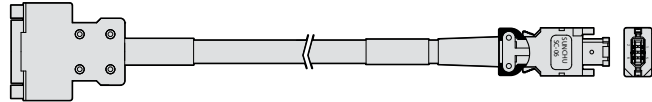
DD Motor Signal Cable

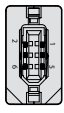
Type	Product Type	Model Name <small>Note1)</small>	Applicable Drive <small>Note2)</small>	Applicable Motor	Specifications																																																																								
For Signal	Encoder Cable	APCS-E □□□ ZS	L7SA□□□B L7NHA□□□□U L7PA□□□□U L7NHFA□□□□U iX7NHA□□□□U	All Model of DD Motor	 <p>Cable Bushing</p>  <table border="1"> <caption>D.D SERVO ENCODER CABLE</caption> <thead> <tr> <th>PIN No.</th> <th>Encoder Signal</th> <th>PIN No.</th> <th>Encoder Signal</th> </tr> </thead> <tbody> <tr><td>1</td><td>MA</td><td>9</td><td>+5V</td></tr> <tr><td>2</td><td>SLO</td><td>10</td><td>-</td></tr> <tr><td>3</td><td>-</td><td>11</td><td>-</td></tr> <tr><td>4</td><td>OV</td><td>12</td><td>-</td></tr> <tr><td>5</td><td>SHELD</td><td>13</td><td>-</td></tr> <tr><td>6</td><td>MA</td><td>14</td><td>-</td></tr> <tr><td>7</td><td>SLO</td><td>15</td><td>-</td></tr> <tr><td>8</td><td>-</td><td>-</td><td>-</td></tr> </tbody> </table>  <table border="1"> <thead> <tr> <th>PIN No.</th> <th>Encoder Signal</th> <th>PIN No.</th> <th>Encoder Signal</th> </tr> </thead> <tbody> <tr><td>1</td><td>-</td><td>8</td><td>-</td></tr> <tr><td>2</td><td>-</td><td>9</td><td>-</td></tr> <tr><td>3</td><td>MA</td><td>10</td><td>-</td></tr> <tr><td>4</td><td>MA</td><td>11</td><td>-</td></tr> <tr><td>5</td><td>SLO</td><td>12</td><td>-</td></tr> <tr><td>6</td><td>SLO</td><td>13</td><td>-</td></tr> <tr><td>7</td><td>OV</td><td>14</td><td>+5V</td></tr> <tr><td colspan="2">PLATE</td><td colspan="2">SHIELD</td></tr> </tbody> </table> <p>1. Motor Side Connector</p> <ul style="list-style-type: none"> CONNECTOR(D-SUB) : DA-15PF-N(Female) CONNECTOR CASE(D-SUB) : SK-15H-1A <p>2. Drive Side Connector</p> <ul style="list-style-type: none"> CASE Spec: 10314-52A0-008(3M) CONNECTOR Spec: 10114-3000VE(3M) Cable Spec.: 3P×0.25SQ or 3P×24AWG 	PIN No.	Encoder Signal	PIN No.	Encoder Signal	1	MA	9	+5V	2	SLO	10	-	3	-	11	-	4	OV	12	-	5	SHELD	13	-	6	MA	14	-	7	SLO	15	-	8	-	-	-	PIN No.	Encoder Signal	PIN No.	Encoder Signal	1	-	8	-	2	-	9	-	3	MA	10	-	4	MA	11	-	5	SLO	12	-	6	SLO	13	-	7	OV	14	+5V	PLATE		SHIELD	
		PIN No.	Encoder Signal	PIN No.	Encoder Signal																																																																								
1	MA	9	+5V																																																																										
2	SLO	10	-																																																																										
3	-	11	-																																																																										
4	OV	12	-																																																																										
5	SHELD	13	-																																																																										
6	MA	14	-																																																																										
7	SLO	15	-																																																																										
8	-	-	-																																																																										
PIN No.	Encoder Signal	PIN No.	Encoder Signal																																																																										
1	-	8	-																																																																										
2	-	9	-																																																																										
3	MA	10	-																																																																										
4	MA	11	-																																																																										
5	SLO	12	-																																																																										
6	SLO	13	-																																																																										
7	OV	14	+5V																																																																										
PLATE		SHIELD																																																																											
		APCS-E □□□ ZM	iX7M-A- □□□□B	All Model of DD Motor	  <table border="1"> <caption>D.D SERVO ENCODER CABLE</caption> <thead> <tr> <th>PIN No.</th> <th>Encoder Signal</th> <th>PIN No.</th> <th>Encoder Signal</th> </tr> </thead> <tbody> <tr><td>1</td><td>MA</td><td>9</td><td>+5V</td></tr> <tr><td>2</td><td>SLO</td><td>10</td><td>-</td></tr> <tr><td>3</td><td>-</td><td>11</td><td>-</td></tr> <tr><td>4</td><td>OV</td><td>12</td><td>-</td></tr> <tr><td>5</td><td>SHELD</td><td>13</td><td>-</td></tr> <tr><td>6</td><td>MA</td><td>14</td><td>-</td></tr> <tr><td>7</td><td>SLO</td><td>15</td><td>-</td></tr> <tr><td>8</td><td>-</td><td>-</td><td>-</td></tr> </tbody> </table>  <table border="1"> <thead> <tr> <th>PIN No.</th> <th>Encoder Signal</th> <th>PIN No.</th> <th>Encoder Signal</th> </tr> </thead> <tbody> <tr><td>1</td><td>+5V</td><td>4</td><td>SLO</td></tr> <tr><td>2</td><td>OV</td><td>5</td><td>MA</td></tr> <tr><td>3</td><td>SLO</td><td>6</td><td>MA</td></tr> <tr><td colspan="4">Shield Case SHIELD</td></tr> </tbody> </table> <p>1. Motor Side Connector</p> <ul style="list-style-type: none"> CONNECTOR(D-SUB) : DA-15PF-N(Female) CONNECTOR CASE(D-SUB) : SK-15H-1A <p>2. Drive Side Connector</p> <ul style="list-style-type: none"> CASE Spec: SC-06-4(Sunchu) Cable Spec.: 3P×0.25SQ or 3P×24AWG 	PIN No.	Encoder Signal	PIN No.	Encoder Signal	1	MA	9	+5V	2	SLO	10	-	3	-	11	-	4	OV	12	-	5	SHELD	13	-	6	MA	14	-	7	SLO	15	-	8	-	-	-	PIN No.	Encoder Signal	PIN No.	Encoder Signal	1	+5V	4	SLO	2	OV	5	MA	3	SLO	6	MA	Shield Case SHIELD																			
PIN No.	Encoder Signal	PIN No.	Encoder Signal																																																																										
1	MA	9	+5V																																																																										
2	SLO	10	-																																																																										
3	-	11	-																																																																										
4	OV	12	-																																																																										
5	SHELD	13	-																																																																										
6	MA	14	-																																																																										
7	SLO	15	-																																																																										
8	-	-	-																																																																										
PIN No.	Encoder Signal	PIN No.	Encoder Signal																																																																										
1	+5V	4	SLO																																																																										
2	OV	5	MA																																																																										
3	SLO	6	MA																																																																										
Shield Case SHIELD																																																																													

Note1) The three blank squares in model names indicate the type and length of cables. And the designation is as below.

Cable Length(m)	1	2	3	...	18	19	20
General Cable	N01	N02	N03	...	N18	N19	N20
Robotic Cable	F01	F02	F03	...	F18	F19	F20

Note2) The three blank squares in model names indicate drive capacity. For details regarding the designation, please refer to pages 16 / 22 / 28 / 38 / 44 / 54 / 58 / 66 / 72page

DD Motor Power Cable

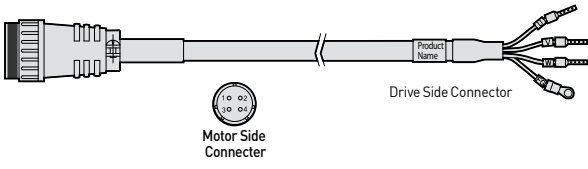
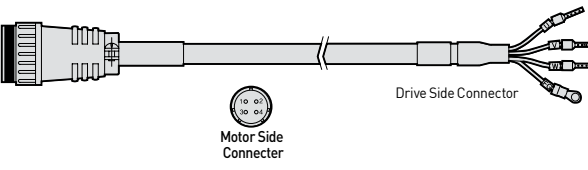
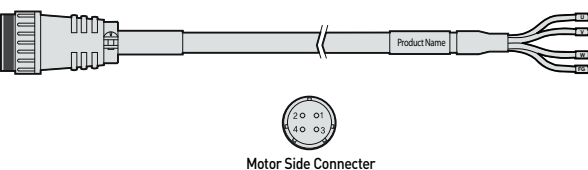
Type	Product Type	Model Name ^{Note1)}	Applicable Drive ^{Note2)}	Applicable Motor	Specifications												
For Power	L7 Power Cable	APCS-PN □□□YS	L7SA□□□B L7NHA□□□U L7PA□□□U L7NHFA□□□U	DB03D/ DB06D/ DB09D/ DC06D/ DC12D/ DC18D/ DD12D/ DD22D/ DD34D/ DE40D/ DE60D	 <p>1. Motor Side Connector</p> <ul style="list-style-type: none"> • PLUG Spec.: NJC-24-4-ADF(Female) <p>2. Drive Side Connector(U,V,W,FG)</p> <ul style="list-style-type: none"> • U, V, W Pin Spec.: 1512 • FG Pin Spec.: 1.5x4(Ring Terminal) • Cable Spec.: 4C×1.5SQ or 4C×16AWG <p>※ Specifications are subject to change without notice.</p> <table border="1" data-bbox="1149 638 1412 750"> <thead> <tr> <th>Item</th> <th>PIN No.</th> <th>Signal</th> </tr> </thead> <tbody> <tr> <td rowspan="4">Motor</td> <td>1</td> <td>U</td> </tr> <tr> <td>2</td> <td>V</td> </tr> <tr> <td>3</td> <td>W</td> </tr> <tr> <td>4</td> <td>Ground</td> </tr> </tbody> </table>	Item	PIN No.	Signal	Motor	1	U	2	V	3	W	4	Ground
Item	PIN No.	Signal															
Motor	1	U															
	2	V															
	3	W															
	4	Ground															
For Power	L7 Power Cable	APCS-PN □□□ZS	L7SA□□□B L7NHA□□□U L7PA□□□U L7NHFA□□□U	DFA1G/ DFA6G/ DGC3S	 <p>1. Motor Side Connector</p> <ul style="list-style-type: none"> • PLUG Spec.: NJC-24-4-ADF(Female) <p>2. Drive Side Connector</p> <ul style="list-style-type: none"> • U, V, W Pin Spec.: 2512 • FG Pin Spec.: 2.5x4(Ring Terminal) • Cable Spec.: 4C×1.5SQ or 4C×14AWG <p>※ Specifications are subject to change without notice.</p> <table border="1" data-bbox="1149 1064 1412 1176"> <thead> <tr> <th>Item</th> <th>PIN No.</th> <th>Signal</th> </tr> </thead> <tbody> <tr> <td rowspan="4">Motor</td> <td>1</td> <td>U</td> </tr> <tr> <td>2</td> <td>V</td> </tr> <tr> <td>3</td> <td>W</td> </tr> <tr> <td>4</td> <td>Ground</td> </tr> </tbody> </table>	Item	PIN No.	Signal	Motor	1	U	2	V	3	W	4	Ground
Item	PIN No.	Signal															
Motor	1	U															
	2	V															
	3	W															
	4	Ground															
For Power	iX7 Power Cable	APCS-P □□□ YSX	iX7NHA□□□U iX7M-A- □□□□B	DB03D/ DB06D/ DB09D/ DC06D/ DC12D/ DC18D/ DD12D/ DD22D/ DD34D/ DE40D/ DE60D	 <p>1. Motor Side Connector</p> <ul style="list-style-type: none"> • CONNECTOR : NJC-24-4-ADF(Female) (Nanaboshi Electronic) <p>2. Drive Side Connector</p> <ul style="list-style-type: none"> • U, V, W Pin Spec. : F1508 • FG Pin Spec. : F1508 • Cable Spec. : 4C×1.5SQ or 4C×16AWG <p>※ Specifications are subject to change without notice.</p> <table border="1" data-bbox="1149 1523 1412 1635"> <thead> <tr> <th>Item</th> <th>PIN No.</th> <th>Signal</th> </tr> </thead> <tbody> <tr> <td rowspan="4">Motor</td> <td>1</td> <td>U</td> </tr> <tr> <td>2</td> <td>V</td> </tr> <tr> <td>3</td> <td>W</td> </tr> <tr> <td>4</td> <td>Ground</td> </tr> </tbody> </table>	Item	PIN No.	Signal	Motor	1	U	2	V	3	W	4	Ground
Item	PIN No.	Signal															
Motor	1	U															
	2	V															
	3	W															
	4	Ground															

^{Note1)} The three blank squares in model names indicate the type and length of cables. And the designation is as below.

Cable Length(m)	1	2	3	...	18	19	20
General Cable	N01	N02	N03	...	N18	N19	N20
Robotic Cable	F01	F02	F03	...	F18	F19	F20

^{Note2)} The three blank squares in model names indicate drive capacity. For details regarding the designation, please refer to pages 16 / 22 / 28 / 38 / 44 / 54 / 58 / 66 / 72page

DD Motor Power Cable

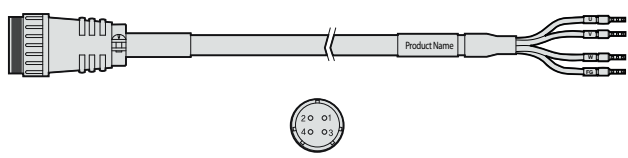
Type	Product Type	Model Name ^{Note1)}	Applicable Drive ^{Note2)}	Applicable Motor	Specifications												
For Power	iX7 Power Cable	APCS-P □□□ ZSX	iX7NHA□□□U iX7M-A- □□□□B	DFA1G/ DFA6G/ DGC3S	 <p style="text-align: center;">Motor Side Connector</p> <p>1. Motor Side Connector • CONNECTOR : NJC-24-4-ADF(Female) (Nanaboshi Electronic)</p> <p>2. Drive Side Connector • U, V, W Pin Spec. : F2508 • FG Pin Spec. : F2508 • Cable Spec. : 4C×2.5SQ or 4C×14AWG</p> <p>※ Specifications are subject to change without notice.</p> <table border="1" style="float: right;"> <thead> <tr> <th>Item</th> <th>PIN No.</th> <th>Signal</th> </tr> </thead> <tbody> <tr> <td rowspan="4">Motor</td> <td>1</td> <td>U</td> </tr> <tr> <td>2</td> <td>V</td> </tr> <tr> <td>3</td> <td>W</td> </tr> <tr> <td>4</td> <td>Ground</td> </tr> </tbody> </table>	Item	PIN No.	Signal	Motor	1	U	2	V	3	W	4	Ground
Item	PIN No.	Signal															
Motor	1	U															
	2	V															
	3	W															
	4	Ground															

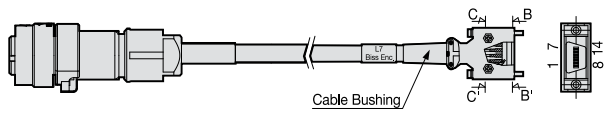

DD Motor Flange Type Signal Cable

Type	Product Type	Model Name ^{Note1)}	Applicable Drive ^{Note2)}	Applicable Motor	Specifications																																																												
For Signal	L7, iX7 Encoder Cable	APCS-E □□□ ZS1	L7SA□□□B L7NHA□□□U L7PA□□□U L7NHFA□□□U iX7NHA□□□U	DFB03D DFC06D DFD12D	 <p style="text-align: center;">Cable Bushing</p> <table border="1" style="float: left; margin-right: 20px;"> <thead> <tr> <th>PIN No.</th> <th>Encoder Signal</th> <th>PIN No.</th> <th>Encoder Signal</th> </tr> </thead> <tbody> <tr> <td>1</td> <td>MA</td> <td>6</td> <td>MA</td> </tr> <tr> <td>2</td> <td>SLO</td> <td>7</td> <td>SLO</td> </tr> <tr> <td>3</td> <td>-</td> <td>8</td> <td>-</td> </tr> <tr> <td>4</td> <td>OV</td> <td>9</td> <td>+5V</td> </tr> <tr> <td>5</td> <td>SHELD</td> <td>10</td> <td>-</td> </tr> </tbody> </table> <table border="1" style="float: right;"> <thead> <tr> <th>PIN No.</th> <th>Encoder Signal</th> <th>PIN No.</th> <th>Encoder Signal</th> </tr> </thead> <tbody> <tr> <td>1</td> <td>-</td> <td>8</td> <td>-</td> </tr> <tr> <td>2</td> <td>-</td> <td>9</td> <td>-</td> </tr> <tr> <td>3</td> <td>MA</td> <td>10</td> <td>-</td> </tr> <tr> <td>4</td> <td>MA</td> <td>11</td> <td>-</td> </tr> <tr> <td>5</td> <td>SLO</td> <td>12</td> <td>-</td> </tr> <tr> <td>6</td> <td>SLO</td> <td>13</td> <td>-</td> </tr> <tr> <td>7</td> <td>OV</td> <td>14</td> <td>+5V</td> </tr> <tr> <td colspan="2" style="text-align: center;">PLATE</td> <td colspan="2" style="text-align: center;">SHIELD</td> </tr> </tbody> </table> <p>1. Motor Side Connector • CONNECTOR : JN1DS10SL1(JAE)</p> <p>2. Drive Side Connector • CONNECTOR CASE : 10314-52A0-008(3M) : SM-14J(Suntone) • CONNECTOR : 10114-3000VE(3M) : SM-14J(Suntone) • Cable Spec. : 3P×0.25SQ or 3P×24AWG</p>	PIN No.	Encoder Signal	PIN No.	Encoder Signal	1	MA	6	MA	2	SLO	7	SLO	3	-	8	-	4	OV	9	+5V	5	SHELD	10	-	PIN No.	Encoder Signal	PIN No.	Encoder Signal	1	-	8	-	2	-	9	-	3	MA	10	-	4	MA	11	-	5	SLO	12	-	6	SLO	13	-	7	OV	14	+5V	PLATE		SHIELD	
PIN No.	Encoder Signal	PIN No.	Encoder Signal																																																														
1	MA	6	MA																																																														
2	SLO	7	SLO																																																														
3	-	8	-																																																														
4	OV	9	+5V																																																														
5	SHELD	10	-																																																														
PIN No.	Encoder Signal	PIN No.	Encoder Signal																																																														
1	-	8	-																																																														
2	-	9	-																																																														
3	MA	10	-																																																														
4	MA	11	-																																																														
5	SLO	12	-																																																														
6	SLO	13	-																																																														
7	OV	14	+5V																																																														
PLATE		SHIELD																																																															



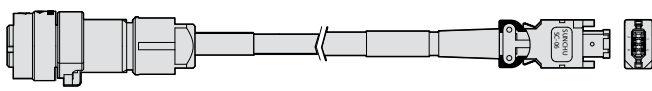

^{Note1)} The three blank squares in model names indicate the type and length of cables. And the designation is as below.

Cable Length(m)	1	2	3	...	18	19	20
General Cable	N01	N02	N03	...	N18	N19	N20
Robotic Cable	F01	F02	F03	...	F18	F19	F20

^{Note2)} The three blank squares in model names indicate drive capacity. For details regarding the designation, please refer to pages 16 / 22 / 28 / 38 / 44 / 54 / 58 / 66 / 72page

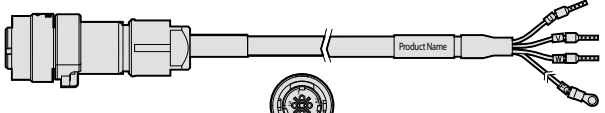
Type	Product Type	Model Name ^{Note1}	Applicable Drive ^{Note2}	Applicable Motor	Specifications																																								
For Signal	Encoder Cable	APCS-E □□□ ZM1	iX7M-A- □□□□B	DFB03D DFC06D DFD12D	  <table border="1" data-bbox="829 571 1061 705"> <thead> <tr> <th>PIN No.</th> <th>Encoder Signal</th> <th>PIN No.</th> <th>Encoder Signal</th> </tr> </thead> <tbody> <tr><td>1</td><td>MA</td><td>6</td><td>MA</td></tr> <tr><td>2</td><td>SLO</td><td>7</td><td>SLO</td></tr> <tr><td>3</td><td>-</td><td>8</td><td>-</td></tr> <tr><td>4</td><td>OV</td><td>9</td><td>+5V</td></tr> <tr><td>5</td><td>SHELD</td><td>10</td><td>-</td></tr> </tbody> </table>  <table border="1" data-bbox="1173 571 1412 683"> <thead> <tr> <th>PIN No.</th> <th>Encoder Signal</th> <th>PIN No.</th> <th>Encoder Signal</th> </tr> </thead> <tbody> <tr><td>1</td><td>+5V</td><td>4</td><td>SLO</td></tr> <tr><td>2</td><td>OV</td><td>5</td><td>MA</td></tr> <tr><td>3</td><td>SLO</td><td>6</td><td>MA</td></tr> </tbody> </table> <p style="text-align: center;">Shield Case SHIELD</p> <p>1. Motor Side Connector • CONNECTOR : JN1DS10SL1(JAE)</p> <p>2. Drive Side Connector • CONNECTOR : JN1DS10SL1(JAE) • Cable Spec. : 3P×0.25SQ or 3P×24AWG</p>	PIN No.	Encoder Signal	PIN No.	Encoder Signal	1	MA	6	MA	2	SLO	7	SLO	3	-	8	-	4	OV	9	+5V	5	SHELD	10	-	PIN No.	Encoder Signal	PIN No.	Encoder Signal	1	+5V	4	SLO	2	OV	5	MA	3	SLO	6	MA
PIN No.	Encoder Signal	PIN No.	Encoder Signal																																										
1	MA	6	MA																																										
2	SLO	7	SLO																																										
3	-	8	-																																										
4	OV	9	+5V																																										
5	SHELD	10	-																																										
PIN No.	Encoder Signal	PIN No.	Encoder Signal																																										
1	+5V	4	SLO																																										
2	OV	5	MA																																										
3	SLO	6	MA																																										

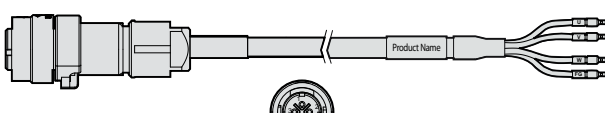
DD Motor Flange Type Power Cable

Type	Product Type	Model Name ^{Note1}	Applicable Drive ^{Note2}	Applicable Motor	Specifications												
For Power	L7 Power Cable	APCS-P □□□ YS1	L7SA□□□B L7NHA□□□U L7PA□□□U L7NHFA□□□U	DFB03D DFC06D DFD12D	  <p style="text-align: center;">Motor Side Connector</p> <p>1. Motor Side Connector • CONNECTOR : JN1DS04FK1(JAE)</p> <p>2. Drive Side Connector • U, V, W Pin Spec. : F1512 • FG Pin Spec. : 1.5×4 • Cable Spec. : 4C×0.75SQ or 4C×18AWG</p> <table border="1" data-bbox="1173 1332 1444 1444"> <thead> <tr> <th>Item</th> <th>PIN No.</th> <th>Signal</th> </tr> </thead> <tbody> <tr><td rowspan="4">Motor</td><td>1</td><td>U</td></tr> <tr><td>2</td><td>V</td></tr> <tr><td>3</td><td>W</td></tr> <tr><td>4</td><td>Ground</td></tr> </tbody> </table>	Item	PIN No.	Signal	Motor	1	U	2	V	3	W	4	Ground
Item	PIN No.	Signal															
Motor	1	U															
	2	V															
	3	W															
	4	Ground															
For Power	iX7 Power Cable	APCS-P □□□ YS1	iX7NHA□□□U iX7M-A- □□□□B	DFB03D DFC06D DFD12D	  <p style="text-align: center;">Motor Side Connector</p> <p>1. Motor Side Connector • CONNECTOR : JN1DS04FK1(JAE)</p> <p>2. Drive Side Connector • U, V, W Pin Spec. : 1008 or 010008 • FG Pin Spec. : 1008 or 010008 • Cable Spec. : 4C×0.75SQ or 4C×18AWG</p> <table border="1" data-bbox="1173 1713 1444 1825"> <thead> <tr> <th>Item</th> <th>PIN No.</th> <th>Signal</th> </tr> </thead> <tbody> <tr><td rowspan="4">Motor</td><td>1</td><td>U</td></tr> <tr><td>2</td><td>V</td></tr> <tr><td>3</td><td>W</td></tr> <tr><td>4</td><td>Ground</td></tr> </tbody> </table>	Item	PIN No.	Signal	Motor	1	U	2	V	3	W	4	Ground
Item	PIN No.	Signal															
Motor	1	U															
	2	V															
	3	W															
	4	Ground															

^{Note1} The three blank squares in model names indicate the type and length of cables. And the designation is as below.

Cable Length(m)	1	2	3	...	18	19	20
General Cable	N01	N02	N03	...	N18	N19	N20
Robotic Cable	F01	F02	F03	...	F18	F19	F20

^{Note2} The three blank squares in model names indicate drive capacity. For details regarding the designation, please refer to pages 16 / 22 / 28 / 38 / 44 / 54 / 58 / 66 / 72page

PHOX Series Cable

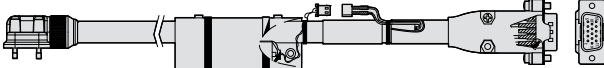
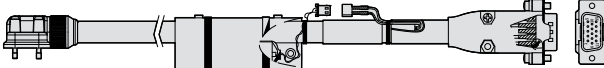
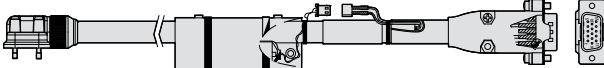
Type	Product Type	Model Name ^{Note1}	Applicable Drive ^{Note2}	Applicable Motor	Specifications																																								
For Signal	Encoder Cable (Single-Turn)	APCV-E □□□ ES-□	PHOX Series PHOX-03/ PHOX-06	FAL (Low Voltage) Series (All Models of Low Voltage Motors)	 <table border="1"> <thead> <tr> <th>PIN No.</th> <th>Encoder Signal</th> <th>PIN No.</th> <th>Encoder Signal</th> </tr> </thead> <tbody> <tr> <td>1</td> <td>MA</td> <td>9</td> <td>-</td> </tr> <tr> <td>2</td> <td>SLO</td> <td>10</td> <td>-</td> </tr> <tr> <td>3</td> <td>-</td> <td>11</td> <td>MA</td> </tr> <tr> <td>4</td> <td>0V</td> <td>12</td> <td>MA</td> </tr> <tr> <td>5</td> <td>SHIELD</td> <td>13</td> <td>-</td> </tr> <tr> <td>6</td> <td>MA</td> <td>14</td> <td>-</td> </tr> <tr> <td>7</td> <td>SLO</td> <td>15</td> <td>-</td> </tr> <tr> <td>8</td> <td>-</td> <td>Plate</td> <td>SHIELD</td> </tr> <tr> <td>9</td> <td>+5V</td> <td></td> <td></td> </tr> </tbody> </table> <p>(Motor Connector) (Driver Connector)</p> <p>1. Motor Side Connector</p> <ul style="list-style-type: none"> • CAP Spec: 2201825-1(Tyco) • SOCKET Spec: 2174065-4(Tyco) <p>2. Drive Side Connector</p> <ul style="list-style-type: none"> • CASE Spec: 5748676-1(Tyco) • CONNECTOR Spec: 10090769-P154ALF(Amphenol FCI) • Cable Spec.: 3Px0.25Q or 3Px24AWG 	PIN No.	Encoder Signal	PIN No.	Encoder Signal	1	MA	9	-	2	SLO	10	-	3	-	11	MA	4	0V	12	MA	5	SHIELD	13	-	6	MA	14	-	7	SLO	15	-	8	-	Plate	SHIELD	9	+5V		
				PIN No.	Encoder Signal	PIN No.	Encoder Signal																																						
1	MA	9	-																																										
2	SLO	10	-																																										
3	-	11	MA																																										
4	0V	12	MA																																										
5	SHIELD	13	-																																										
6	MA	14	-																																										
7	SLO	15	-																																										
8	-	Plate	SHIELD																																										
9	+5V																																												
FBL (Low Voltage) Series (All Models of Low Voltage Motors)	 <table border="1"> <thead> <tr> <th>PIN No.</th> <th>Encoder Signal</th> <th>PIN No.</th> <th>Encoder Signal</th> </tr> </thead> <tbody> <tr> <td>1</td> <td>MA</td> <td>9</td> <td>-</td> </tr> <tr> <td>2</td> <td>SLO</td> <td>10</td> <td>-</td> </tr> <tr> <td>3</td> <td>GND_B</td> <td>11</td> <td>MA</td> </tr> <tr> <td>4</td> <td>0V</td> <td>12</td> <td>MA</td> </tr> <tr> <td>5</td> <td>SHIELD</td> <td>13</td> <td>-</td> </tr> <tr> <td>6</td> <td>MA</td> <td>14</td> <td>-</td> </tr> <tr> <td>7</td> <td>SLO</td> <td>15</td> <td>-</td> </tr> <tr> <td>8</td> <td>VDD_B</td> <td>Plate</td> <td>SHIELD</td> </tr> <tr> <td>9</td> <td>+5V</td> <td></td> <td></td> </tr> </tbody> </table> <p>(Battery Connector) (Motor Connector) (Driver Connector)</p> <p>1. Motor Side Connector</p> <ul style="list-style-type: none"> • CAP Spec: 2201825-1(Tyco) • SOCKET Spec: 2174065-4(Tyco) <p>2. Drive Side Connector</p> <ul style="list-style-type: none"> • CASE Spec: 5748676-1(Tyco) • CONNECTOR Spec: 10090769-P154ALF(Amphenol FCI) • Cable Spec.: 4Px0.25Q or 4Px24AWG • BATTERY CONNECTOR Spec: 5267-02A(MOLEX) 	PIN No.	Encoder Signal	PIN No.	Encoder Signal	1	MA	9	-	2	SLO	10	-	3	GND_B	11	MA	4	0V	12	MA	5	SHIELD	13	-	6	MA	14	-	7	SLO	15	-	8	VDD_B	Plate	SHIELD	9	+5V						
PIN No.	Encoder Signal	PIN No.	Encoder Signal																																										
1	MA	9	-																																										
2	SLO	10	-																																										
3	GND_B	11	MA																																										
4	0V	12	MA																																										
5	SHIELD	13	-																																										
6	MA	14	-																																										
7	SLO	15	-																																										
8	VDD_B	Plate	SHIELD																																										
9	+5V																																												
For Signal	Encoder Cable (Multi-Turn)	APCV-E □□□ ES1-□	PHOX Series PHOX-03/ PHOX-06	FAL (Low Voltage) Series (All Models of Low Voltage Motors)	 <table border="1"> <thead> <tr> <th>PIN No.</th> <th>Encoder Signal</th> <th>PIN No.</th> <th>Encoder Signal</th> </tr> </thead> <tbody> <tr> <td>1</td> <td>BATTERY (VDD_B)</td> <td>9</td> <td>-</td> </tr> <tr> <td>2</td> <td>BATTERY 0V (GND_B)</td> <td>10</td> <td>-</td> </tr> <tr> <td></td> <td></td> <td>11</td> <td>MA</td> </tr> <tr> <td></td> <td></td> <td>12</td> <td>MA</td> </tr> <tr> <td></td> <td></td> <td>13</td> <td>-</td> </tr> <tr> <td></td> <td></td> <td>14</td> <td>-</td> </tr> <tr> <td></td> <td></td> <td>15</td> <td>-</td> </tr> <tr> <td></td> <td></td> <td>Plate</td> <td>SHIELD</td> </tr> <tr> <td></td> <td></td> <td></td> <td></td> </tr> </tbody> </table> <p>(Battery Connector) (Motor Connector) (Driver Connector)</p> <p>1. Motor Side Connector</p> <ul style="list-style-type: none"> • CAP Spec: 2201825-1(Tyco) • SOCKET Spec: 2174065-4(Tyco) <p>2. Drive Side Connector</p> <ul style="list-style-type: none"> • CASE Spec: 5748676-1(Tyco) • CONNECTOR Spec: 10090769-P154ALF(Amphenol FCI) • Cable Spec.: 4Px0.25Q or 4Px24AWG • BATTERY CONNECTOR Spec: 5267-02A(MOLEX) 	PIN No.	Encoder Signal	PIN No.	Encoder Signal	1	BATTERY (VDD_B)	9	-	2	BATTERY 0V (GND_B)	10	-			11	MA			12	MA			13	-			14	-			15	-			Plate	SHIELD				
				PIN No.	Encoder Signal	PIN No.	Encoder Signal																																						
1	BATTERY (VDD_B)	9	-																																										
2	BATTERY 0V (GND_B)	10	-																																										
		11	MA																																										
		12	MA																																										
		13	-																																										
		14	-																																										
		15	-																																										
		Plate	SHIELD																																										
FBL (Low Voltage) Series (All Models of Low Voltage Motors)	 <table border="1"> <thead> <tr> <th>PIN No.</th> <th>Encoder Signal</th> <th>PIN No.</th> <th>Encoder Signal</th> </tr> </thead> <tbody> <tr> <td>1</td> <td>MA</td> <td>9</td> <td>-</td> </tr> <tr> <td>2</td> <td>SLO</td> <td>10</td> <td>-</td> </tr> <tr> <td>3</td> <td>GND_B</td> <td>11</td> <td>MA</td> </tr> <tr> <td>4</td> <td>0V</td> <td>12</td> <td>MA</td> </tr> <tr> <td>5</td> <td>SHIELD</td> <td>13</td> <td>-</td> </tr> <tr> <td>6</td> <td>MA</td> <td>14</td> <td>-</td> </tr> <tr> <td>7</td> <td>SLO</td> <td>15</td> <td>-</td> </tr> <tr> <td>8</td> <td>VDD_B</td> <td>Plate</td> <td>SHIELD</td> </tr> <tr> <td>9</td> <td>+5V</td> <td></td> <td></td> </tr> </tbody> </table> <p>(Battery Connector) (Motor Connector) (Driver Connector)</p> <p>1. Motor Side Connector</p> <ul style="list-style-type: none"> • CAP Spec: 2201825-1(Tyco) • SOCKET Spec: 2174065-4(Tyco) <p>2. Drive Side Connector</p> <ul style="list-style-type: none"> • CASE Spec: 5748676-1(Tyco) • CONNECTOR Spec: 10090769-P154ALF(Amphenol FCI) • Cable Spec.: 4Px0.25Q or 4Px24AWG • BATTERY CONNECTOR Spec: 5267-02A(MOLEX) 	PIN No.	Encoder Signal	PIN No.	Encoder Signal	1	MA	9	-	2	SLO	10	-	3	GND_B	11	MA	4	0V	12	MA	5	SHIELD	13	-	6	MA	14	-	7	SLO	15	-	8	VDD_B	Plate	SHIELD	9	+5V						
PIN No.	Encoder Signal	PIN No.	Encoder Signal																																										
1	MA	9	-																																										
2	SLO	10	-																																										
3	GND_B	11	MA																																										
4	0V	12	MA																																										
5	SHIELD	13	-																																										
6	MA	14	-																																										
7	SLO	15	-																																										
8	VDD_B	Plate	SHIELD																																										
9	+5V																																												

Note1 The three blank squares in model names indicate the type and length of cables. And the designation is as below.
 In case a model name contains a single blank square, the connector can draw towards both front(load) and rear(half-load). (Front Type: no markings, Rear Type: marked -R)
 The FAL Type can only draw towards front.

Cable Length(m)	1	2	3	...	18	19	20
General Cable	N01	N02	N03	...	N18	N19	N20
Robotic Cable	F01	F02	F03	...	F18	F19	F20

Note2 The three blank squares in model names indicate drive capacity. For details regarding the designation, please refer to pages 16 / 22 / 28 / 38 / 44 / 54 / 58 / 66 / 72page

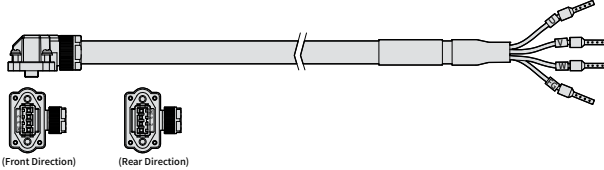
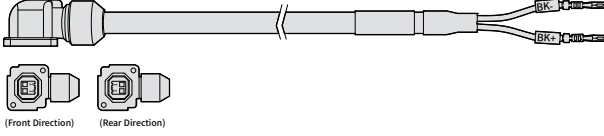
Type	Product Type	Model Name ^{Note1)}	Applicable Drive ^{Note2)}	Applicable Motor	Specifications										
For Power	Power Cable	APCV-P □□□LS -□	PHOX Series PHOX-03/ PHOX-06	FAL (Low Voltage) Series (All Models of Low Voltage Motors) FBL (Low Voltage) Series (All Models of Low Voltage Motors)	 <p>1. Motor Side Connector</p> <ul style="list-style-type: none"> • CAP Spec: SM-JN8FT04N(Suntone) • SOCKET Spec: SMS-201(Suntone) <p>2. Drive Side Connector</p> <ul style="list-style-type: none"> • U, V, W Pin Spec: F1506 • FG Pin Spec: F1506 • Cable Spec.: 4Cx0.75SQ or 4Cx18AWG <table border="1"> <thead> <tr> <th>PIN No.</th> <th>Signal</th> </tr> </thead> <tbody> <tr> <td>1</td> <td>U</td> </tr> <tr> <td>2</td> <td>V</td> </tr> <tr> <td>3</td> <td>W</td> </tr> <tr> <td>PE</td> <td>Ground</td> </tr> </tbody> </table>	PIN No.	Signal	1	U	2	V	3	W	PE	Ground
PIN No.	Signal														
1	U														
2	V														
3	W														
PE	Ground														
For Power	Brake Cable	APCV-B □□□QS	PHOX Series PHOX-03/ PHOX-06	FAL (Low Voltage) Series (All Models of Low Voltage Motors) FBL (Low Voltage) Series (All Models of Low Voltage Motors)	 <p>1. Motor Side Connector</p> <ul style="list-style-type: none"> • CAP Spec: KN5FT02SJ1(JAE) • SOCKET Spec: ST-KN-S-C1B-3500(JAE) <p>2. Drive Side Connector</p> <ul style="list-style-type: none"> • Connecting Terminal Spec.: CC79X-2024-01-X • Cable Spec.: 2Cx0.5SQ or 2Cx20AWG <table border="1"> <thead> <tr> <th>PIN No.</th> <th>Signal</th> </tr> </thead> <tbody> <tr> <td>1</td> <td>+</td> </tr> <tr> <td>2</td> <td>-</td> </tr> </tbody> </table>	PIN No.	Signal	1	+	2	-				
PIN No.	Signal														
1	+														
2	-														

^{Note1)} The three blank squares in model names indicate the type and length of cables. And the designation is as below.

Cable Length(m)	1	2	3	...	18	19	20
General Cable	N01	N02	N03	...	N18	N19	N20
Robotic Cable	F01	F02	F03	...	F18	F19	F20

^{Note2)} The three blank squares in model names indicate drive capacity. For details regarding the designation, please refer to pages 16 / 22 / 28 / 38 / 44 / 54 / 58 / 66 / 72page

Signal Cable

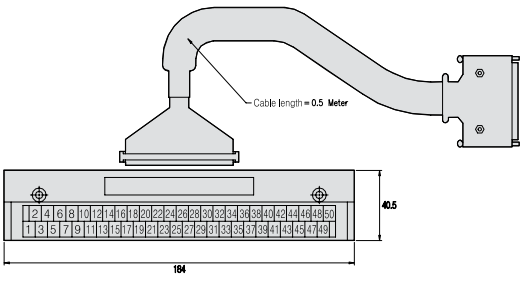
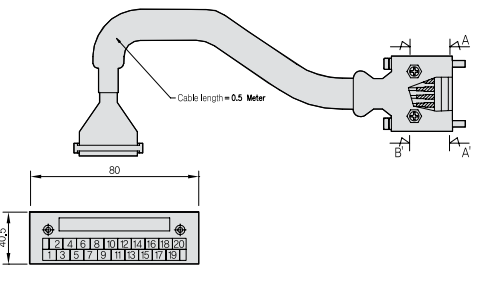
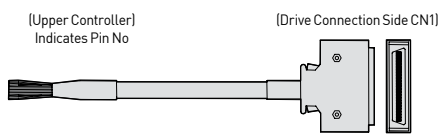
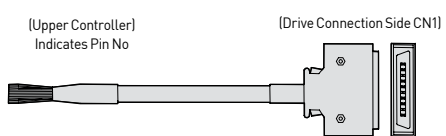
Type	Product Type	Model Name ^{Note1}	Applicable Drive ^{Note2}	Specifications
T/B	CN1 T/B	APC-VSCN1T-□□	L7S□□□□B L7P□□□□U L7CA□□□□U	 <ul style="list-style-type: none"> • CN1 T/B extended model for Pulse Type Drive • Available Cable Length: 0.5[m], 1[m], 1.5[m], 2[m], 3[m]
	CN1 T/B	APCS-L7NCN1T-□□	L7NH□□□□U iX7NH□□□□U	 <ul style="list-style-type: none"> • CN1 T/B extended model for EtherCAT Drive • Available Cable Length: 0.5[m], 1[m], 1.5[m], 2[m]
For Signal	CN1 Cable	APC-CN1-□□□A	L7S□□□□B L7P□□□□U L7CA□□□□U	 <p>Drive Side Connection(CN1)</p> <ul style="list-style-type: none"> • CASE Spec. : 10350-52A0-008(3M) • CONNECTOR Spec. : 10150-3000VE(3M) • CABLE Spec. : 20276-SB 25P(AWG28)
For Signal	CN1 Cable	APCS-CN1-□□□A	L7NH SERIES iX7NHA□□□□U	 <p>Drive Side Connection(CN1)</p> <ul style="list-style-type: none"> • CASE Spec. : 10320-52A0-008(3M) • CONNECTOR Spec. : 10120-3000VE(3M) • CABLE Spec. : ROW-SB0.1C×20C(AWG28)

Note1) The three blank squares in model names indicate the type and length of cables. And the designation is as below.

Cable Length(m)	3	5	10	20
General Cable(N)	N03	N05	N10	N20
Robotic Cable(F)	F03	F05	F10	F20

APC-VSCN1T

Cable Length(m)	0.5	1	1.5	2	3
Designation	None	01	015	02	03

APCS-L7NCN1T

Cable Length(m)	0.5	1	1.5	2
Designation	None	01	015	02

Note2) The three blank squares in model names indicate drive capacity. For details regarding the designation, please refer to pages 16 / 22 / 28 / 38 / 44 / 54 / 58 / 66 / 72page

L7C CN1 Pin Map

L7S/L7C

NO	PIN Function	NO	PIN Function	NO	PIN Function	NO	PIN Function	NO	PIN Function
1	TRQCOM	11	PR+	21	SPD3	31	/BO	41	RDY
2		12	PR-	22	SPD2	32	AO	42	
3		13		23	SPD1	33	/AO	43	ZSPD
4	ZO	14	ALO2	24	GND24	34	+12VA	44	BRAKE
5	/ZO	15	ALO1	25	GND24	35	-12VA	45	INPOS
6		16	AL00	26		36	SG	46	DIR
7		17	ALMRST	27	SPDCOM	37	GND	47	SVON
8	GND	18	EMG	28	MINIY1	38	ALARM+	48	STOP
9	PF+	19	CWLIM	29	MINIY2	39	ALARM-	49	PULCOM
10	PF-	20	CCWLIM	30	BO	40	RDY+	50	+24VIN

L7P

NO	PIN Function	NO	PIN Function	NO	PIN Function	NO	PIN Function	NO	PIN Function
1	AO	11	+24V IN	21	+24V IN	31	PF+	41	INPOS1+
2	/AO	12	SVON	22	HOME	32	PF-	42	INPOS1-
3	BO	13	POT	23	H-START	33	PR+	43	ORG+
4	/BO	14	NOT	24	ISEL0	34	PR-	44	ORG-
5	ZO	15	A-RST	25	ISEL1	35	ALARM+	45	EOS+
6	/ZO	16	START	26	ISEL2	36	ALARM-	46	EOS-
7	A-TLMT	17	STOP	27	ISEL3	37	RDY+	47	TGON+
8	AGND	18	REGT	28	ISEL4	38	RDY-	48	TGON-
9	A-OVR	19	EMG	29	ISEL5	39	BRAKE+	49	TLMT+
10	AGND	20		30	PULCOM	40	BRAKE-	50	TLMT-

L7NH

NO	PIN Function	NO	PIN Function
1	BRAKE+	11	POT
2	BRAKE-	12	NOT
3	RDY+	13	PCON
4	RDY-	14	GAIN2
5	AGND	15	A-TLMT
6	+24V IN	16	
7	HOME	17	ALARM+
8	STOP	18	ALARM-
9	PCL	19	ZSPD+
10	NCL	20	ZSPD-



iX7NH

NO	PIN Function	NO	PIN Function
1	BRAKE	11	POT
2	DOCOM	12	NOT
3	ALARM	13	PCON
4	READY	14	GAIN2
5	AGND	15	A-TLMT
6	+24V IN	16	GND
7	HOME	17	ZO
8	STOP	18	/ZO
9	AO	19	BO
10	/AO	20	/BO

Signal Cable / Connector

Type	Product Type	Model Name ^{Note1)}	Applicable Drive ^{Note2)}	Specifications
For Signal	Communication Cable	APCS-CN5L7U	All Models of iX7NH, L7 Series, PEGA Series, PHOX Series	 <p>(PC - USB Port) (Servo Drive - CN5)</p> <ul style="list-style-type: none"> • PC Side Connector : USB A Plug • Drive Side Connector(CN5) : Mini USB 5P Plug • Electric Requirements Spec : Double Shielded, Twisted Pair, EMI-filter attached type (Ex. : KU-AMB518, SANWA) • Only 1.8m length of cable is available to use

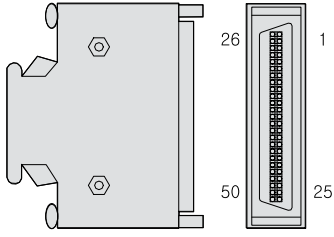
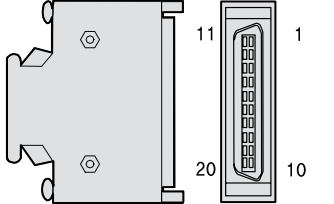
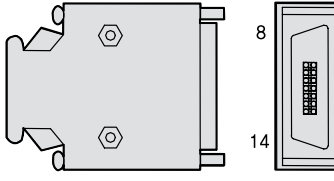
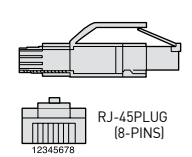
Options (Connectors)

Type	Product Type	Model Name	Applicable Drive ^{Note1}	Specifications																														
CN	CN1 Connector	APC-CN1NNA	L7S□□□B L7CA□□□U L7PA□□□U	 <ul style="list-style-type: none"> • CASE Spec. : 10350-52A0-008(3M) • CONNECTOR Spec. : 10150-3000VE(3M) 																														
CN	CN1 Connector	APC-CN2NNA	L7NH□□□U iX7NHA□□□U	 <ul style="list-style-type: none"> • CASE Spec. : 10320-52A0-008(3M) • CONNECTOR Spec. : 10120-3000VE(3M) 																														
CN	CN2 Connector	APC-CN3NNA	All model of iX7NH SERIES L7 SERIES	 <ul style="list-style-type: none"> • CASE Spec. : 10314-52A0-008(3M) • CONNECTOR Spec. : 10114-3000VE(3M) 																														
CN	CN3 CN4 EtherCAT Connector	APCS-CN4NNA	L7NH□□□U L7NHF□□□U iX7NHA□□□U iX7M- A□□□□B	 <table border="1"> <thead> <tr> <th>PIN No.</th> <th>Signal</th> <th>Line Color</th> </tr> </thead> <tbody> <tr> <td>1</td> <td>TX/RX0 Plus</td> <td>White/Orange</td> </tr> <tr> <td>2</td> <td>TX/RX0 Minus</td> <td>Orange</td> </tr> <tr> <td>3</td> <td>TX/RX1 Plus</td> <td>White/Green</td> </tr> <tr> <td>4</td> <td>TX/RX2 Plus</td> <td>Blue</td> </tr> <tr> <td>5</td> <td>TX/RX2 Minus</td> <td>White/Blue</td> </tr> <tr> <td>6</td> <td>TX/RX1 Minus</td> <td>Green</td> </tr> <tr> <td>7</td> <td>TX/RX3 Plus</td> <td>White/Brown</td> </tr> <tr> <td>8</td> <td>TX/RX3 Minus</td> <td>Brown</td> </tr> <tr> <td></td> <td>PLATE</td> <td>SHIELD</td> </tr> </tbody> </table> <p>* EtherCAT use only 4 Signal(1, 2, 3, 6)</p>	PIN No.	Signal	Line Color	1	TX/RX0 Plus	White/Orange	2	TX/RX0 Minus	Orange	3	TX/RX1 Plus	White/Green	4	TX/RX2 Plus	Blue	5	TX/RX2 Minus	White/Blue	6	TX/RX1 Minus	Green	7	TX/RX3 Plus	White/Brown	8	TX/RX3 Minus	Brown		PLATE	SHIELD
PIN No.	Signal	Line Color																																
1	TX/RX0 Plus	White/Orange																																
2	TX/RX0 Minus	Orange																																
3	TX/RX1 Plus	White/Green																																
4	TX/RX2 Plus	Blue																																
5	TX/RX2 Minus	White/Blue																																
6	TX/RX1 Minus	Green																																
7	TX/RX3 Plus	White/Brown																																
8	TX/RX3 Minus	Brown																																
	PLATE	SHIELD																																
CN	CN6 Connector	APCS-CN6K	L7NH□□□U iX7NHA□□□U iX7M- A□□□□B	 <p>Pin No.</p>  <p>Wiring Schematic</p> <ul style="list-style-type: none"> • MINI I/O By-pass Connector : 1971153(TE) 																														

Note1 The former blank square in model names indicates drive type, and the latter indicates encoder type.
For details regarding the designation, please refer to pages 16 / 22 / 28 / 38 / 44 / 54 / 58 / 66 / 72page

200V Braking Resistor

*Optional braking resistors are selectable items for user's need.

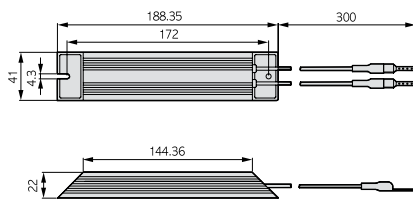
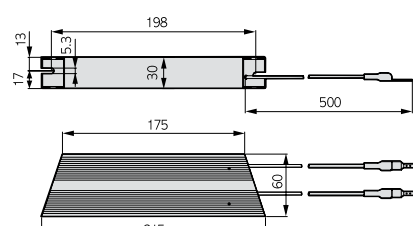
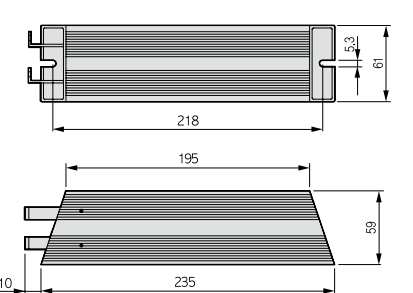
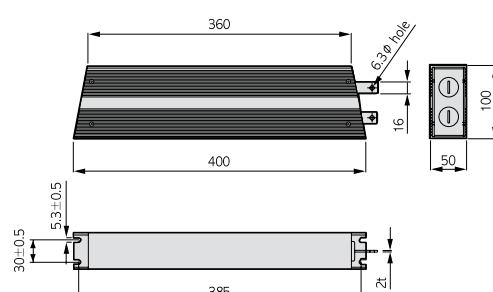
Type	Product Type	Model Name ^{Note1)}	Applicable Drive ^{Note2)}	Specifications
Resistor	Braking Resistor	APCS-140R50 (50Ω/140W)	L7□A001□ L7□A002□ L7□A004□ iX7□A001□ iX7□A002□ iX7□A004□ iX7M-A-22XXB iX7M-A-44XXB iX7M-A-222XB iX7M-A-2222B	 <ul style="list-style-type: none"> • IRH140-50Ω
Resistor	Braking Resistor	APCS-300R30 (30Ω/300W)	L7□A008□ L7□A010□ iX7□A008□ iX7□A010□ iX7M-A-88XXB iX7M-A-AAXXB iX7M-A-444XB iX7M-A-4444B	 <ul style="list-style-type: none"> • IRV300-30Ω
Resistor	Braking Resistor	APC-600R30 ×2P(Parallel) (30Ω/600W ×2P(Parallel) =15Ω/1200W) APC-600R30 ×3P(Parallel) (30Ω/600W ×3P(Parallel) =10Ω/1800W) APC-600R28 ×4P(Parallel) (28Ω/600W ×4P(Parallel) =7Ω/2400W)	L7□A020□ iX7□A020□ L7□A035□ iX7□A035□ L7□A050□ L7□A075□	 <ul style="list-style-type: none"> • IRV600-30Ω • IRV600-28Ω <p>Note) IRV600-30Ω and IRV600-28Ω have the same external dimensions.</p>
Resistor	Braking Resistor	APCS-2000R3R3 (3.3Ω/2000W)	L7□A150□	 <ul style="list-style-type: none"> • IRM2000-3.3Ω

Note1) Products in the L7 Series(100W to 7.5kW) are internally equipped with the same braking resistor.
If your device is prone to regeneration, please refer to the table above and select the appropriate optional braking resistor.

Note2) The former blank square in model names indicates drive type, and the latter indicates encoder type.
For details regarding the designation, please refer to pages 16 / 22 / 28 / 38 / 44 / 54 / 58 / 66 / 72page

400V Braking Resistor

*Optional braking resistors are selectable items for user's need.

Type	Product Type	Model Name ^{Note1}	Applicable Drive ^{Note2}	Specifications
Resistor	Braking Resistor	APCS-300R82 (82Ω/300W)	L7□B010□	<p>• IRV300-82Ω</p>
Resistor	Braking Resistor	APCS-600R75 ×2P[Parallel] (75Ω/600W ×2P[Parallel] =37.5Ω/1200W)	L7□B020□ L7□B035□	<p>t2x10mm(5.3 Hole or M5 Tap)</p> <p>• IRV600-75Ω</p>
Resistor	Braking Resistor	APCS-600R75 ×3P[Parallel] (75Ω/600W ×3P[Parallel] =25Ω/1800W)	L7□B050□ L7□B075□	<p>• IRV600-75Ω</p>
Resistor	Braking Resistor	APCS-2000R13R4 (13.4Ω/2000W)	L7□B150□	<p>• IRM2000-13.4Ω</p>

Note1) Products in the L7 Series(100W to 7.5kW) are internally equipped with the same braking resistor.
If your device is prone to regeneration, please refer to the table above and select the appropriate optional braking resistor.

Note2) The former blank square in model names indicates drive type, and the latter indicates encoder type.
For details regarding the designation, please refer to pages 16 / 22 / 28 / 38 / 44 / 54 / 58 / 66 / 72page

Noise Filter

Type	Product Type	Model Name	Applicable Drive ^{Note2)}	Specifications
Resistor	Noise Filter	APCS-TB6-B010LBEI	L7□A001□ L7□A002□ L7□A004□ L7□A008□ L7□A010□ L7□B010□ iX7□A001□ iX7□A002□ iX7□A004□ iX7□A008□ iX7□A010□ iX7M-A-22XXB iX7M-A-44XXB iX7M-A-222XB iX7M-A-2222B	
		APCS-TB6-B020NBDC	L7□B020□ L7□B035□ iX7M-A-88XXB iX7M-A-AAXXB iX7M-A-444XB iX7M-A-4444B	
		APCS-TB6-B030NBDC	L7□A020□ L7□A035□ L7□B050□ iX7□A020□ iX7□A035□	
		APCS-TB6-B040AS	L7□A050□ L7□B075□	
		APCS-TB6-B060LAS	L7□A075□ L7□B150□	
		APCS-TB6-B080LAS	L7□A150□	

^{Note2)} The former blank square in model names indicates drive type, and the latter indicates encoder type.
 For details regarding the designation, please refer to pages 16 / 22 / 28 / 38 / 44 / 54 / 58 / 66 / 72page

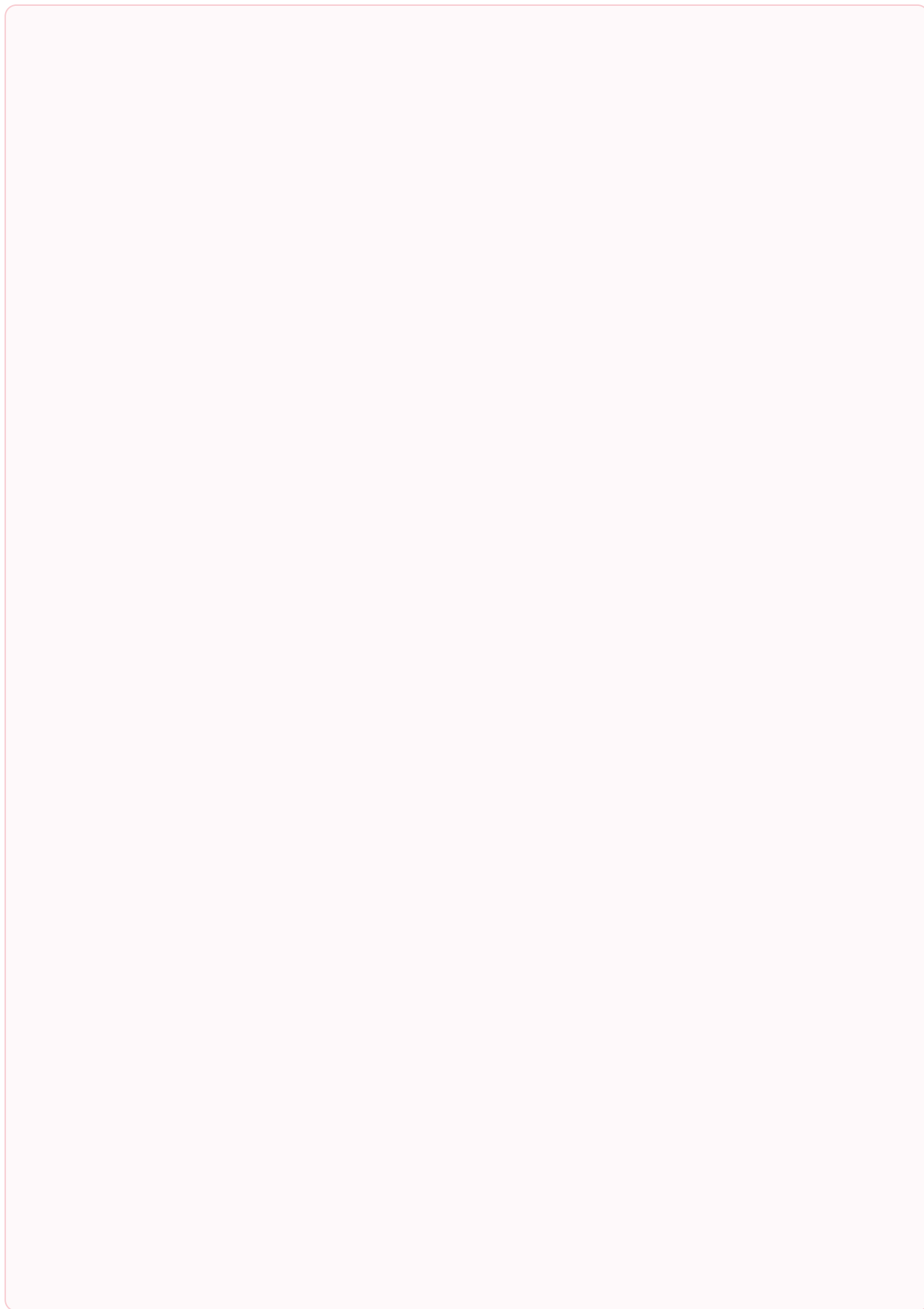

SOLUTION SQUARE

EVERYTHING ABOUT AUTOMATION ENGINEERING



SOLUTION SQUARE provides technical information and training materials across a wide range of automation technologies.

SOLUTION SQUARE

Engineering Software-associated Services

Linked with Automation Software

Users can access graphic libraries and samples in the engineering software in a few clicks.



Simple Software Updates

Check the latest information and keep your software up-to-date.



Quick and Easy Search for Automation Technologies

Getting Effective Search Results

Quick and easy search for up-to-date content of products and technologies



Mobile Friendly

Optimized for web and mobile



Search  SOLUTION SQUARE on Google. Visit at sol.ls-electric.com





Safety Instructions

- For your safety, please read user's manual thoroughly before operating.
- Contact the nearest authorized service facility for examination, repair, or adjustment.
- Please contact qualified service technician when you need maintenance.
Do not disassemble or repair by yourself!
- Any maintenance and inspection shall be performed by the personnel having expertise concerned.



- According to The WEEE Directive, please do not discard the device with your household waste.

vector
Energy

C/Montcada 7, Pol. Ind. Les Pereres
08130 Santa Perpètua de Mogoda
Barcelona (Spain)
T. (+34) 935 748 206
info@vectorenergy.com

www.vectorenergy.com