



Protection and monitoring relay

RDB+



INSTRUCTION MANUAL

(M256BVM-03-20A)



SAFETY PRECAUTIONS

Follow the warnings described in this manual with the symbols shown below.

	<p>DANGER Warns of a risk, which could result in personal injury or material damage.</p>
---	---

	<p>ATTENTION Indicates that special attention should be paid to a specific point.</p>
---	--

If you must handle the unit for its installation, start-up or maintenance, the following should be taken into consideration:

	<p>Incorrect handling or installation of the unit may result in injury to personnel as well as damage to the unit. In particular, handling with voltages applied may result in electric shock, which may cause death or serious injury to personnel. Defective installation or maintenance may also lead to the risk of fire.</p> <p>Read the manual carefully prior to connecting the unit. Follow all installation and maintenance instructions throughout the unit's working life. Pay special attention to the installation standards of the National Electrical Code.</p>
---	--

	<p>Refer to the instruction manual before using the unit</p> <p>In this manual, if the instructions marked with this symbol are not respected or carried out correctly, it can result in injury or damage to the unit and /or installations.</p>
---	---

VMC, reserves the right to modify features or the product manual without prior notification.

DISCLAIMER

VMC, reserves the right to make modifications to the device or the unit specifications set out in this instruction manual without prior notice.

VMC, on its web site, supplies its customers with the latest versions of the device specifications and the most updated manuals.

www.vmc.es

	<p>VMC, recommends using the original cables and accessories that are supplied with the device.</p>
---	---

CONTENTS

SAFETY PRECAUTIONS	3
DISCLAIMER	3
CONTENTS.....	4
REVISION LOG	6
SYMBOLS.....	6
1.- VERIFICATION UPON RECEPTION	7
2 - PRODUCT DESCRIPTION	7
3.- INSTALLATION OF THE DEVICE	9
3.1.- PRELIMINARY RECOMMENDATIONS	9
3.2.- INSTALLATION	10
3.3.- PANEL ADAPTER 72 x 72 mm.....	10
3.4.- DEVICE TERMINALS.....	11
3.5.- TDB TRANSFORMERS	12
3.5.1. PANEL INSTALLATION	12
3.5.2. INSTALLATION ON A DIN RAIL.....	13
3.5.3.- TRANSFORMER TERMINALS	14
3.5.4.- TRANSFORMER LEDs	14
3.6.- CONNECTION DIAGRAMS.....	15
3.7.- INSTALLATION CONNECTIONS	16
4.- OPERATION	17
4.1.- LED INDICATORS	17
4.2.- DISPLAY	18
4.3.- KEYBOARD FUNCTIONS	19
4.4.- DIGITAL OUTPUT	19
4.5.- RELAY	19
4.6.- DIGITAL INPUT.....	19
5.- DISPLAY.....	20
5.1.- CLOCK SETUP MENU.....	20
5.2.- PROBLEMS OR CHANGES IN THE INSTALLATION	21
5.3.- DISPLAY SCREENS.....	22
5.4.- TRIP DISPLAY SCREENS.....	23
5.5.- TEST SCREEN	24
5.6 .- DIRECT SETTINGS	25
5.6.1.- PASSWORD	25
5.6.2.- TRIP CURRENT	25
5.6.3.- DELAY AND RELAY CURVE	26
5.7.- EVENT MENU	26
5.8.- OTHER SCREENS	28
6.- CONFIGURATION	29
6.1.- RS-485 COMMUNICATIONS	30
6.1.1.-BAUD RATE	30
6.1.2.- PERIPHERAL NUMBER.....	31
6.1.3.- DATA FORMAT	31
6.2.- PREALARM	32
6.2.1.- PREALARM CURRENT	32
6.2.2.- PREALARM OPERATION	32
6.4.1.- PASSWORD.....	33
6.3.- CLOCK SETUP	33
6.4.- PASSWORD	33
6.5.- INSTALLATION	34
6.5.1.- SAVE INSTALLATION	34
6.6.- MENU EXIT	34
7.- RS-485 COMMUNICATIONS.....	35
7.1.- CONNECTIONS.....	35
7.2.- MODBUS PROTOCOL	35
7.3.- MODBUS COMMANDS.....	36
7.3.1.- VARIABLES OF THE RDB+ AND INSTALLATION.....	36
7.3.2.- CHANNEL VARIABLES	37
7.3.3.- TRIPPING DUE TO TEST OR COMMUNICATIONS	38

7.3.4.- EVENTS.....	38
7.3.5.- DEVICE CONFIGURATION VARIABLES.....	39
8.- TECHNICAL FEATURES.....	42
8.1.- RDB+.....	42
8.2.- TDB.....	44
9.- MAINTENANCE AND TECHNICAL SERVICE	46
10.- GUARANTEE	46
ANNEX A.- DIRECT SETTINGS.....	47
ANNEX B.- SETUP MENU.....	48





REVISION LOG

Table 1: Revision log.

Date	Revision	Description
03/21	M256BVM-03-20A	First Version

SYMBOLS

Table 2: Symbols.

Symbol	Description
	In accordance with the relevant European directive.
	Device covered by European Directive 2012/19/EC. At the end of its useful life, do not discard of the device in a household refuse bin. Follow local regulations on electronic equipment recycling.
	Direct current.
	Alternating current.

Note: The images of the devices are for illustrative purposes only and may differ from the original device.

1.- VERIFICATION UPON RECEPTION

Upon reception of the device check the following points:

- The device meets the specifications described in your order.
- The device has not suffered any damage during transport.
- Perform an external visual inspection of the device prior to switching it on.
- Check that it has been delivered with the following:

- An installation guide



If any problem is noticed upon reception, immediately contact the transport company and/or VMC's after-sales service.

2 - PRODUCT DESCRIPTION

The **RDB+** is a type-B earth leakage protection and monitoring device (IEC 60755), compatible with the earth leakage transformers in the **TDB** product range, and includes adjustable prealarm leakage sensitivity and integrated RS-485 communications.



The device features:

- **Display** for displaying the parameters.
- **3 keys** to browse through the different screens and program the device.
- **Digital output**, as a prealarm function.
- **Digital input** for external trip.
- **RS-485** communications.

The **TDB** are a range of electronic, type-B earth leakage protection and monitoring transformers (IEC 60755) to be used **with RDB+** earth leakage protection and monitoring relays.

VMC has 4 models, depending on the maximum current of the monitored circuit (**In**):

- ✓ **TDB-35**, for **In: 80 A**.
- ✓ **TDB-55** for **In: 160 A**.
- ✓ **TDB-80** for **In: 250 A**.
- ✓ **TDB-110** for **In: 400 A**.

The transformers have:

- **6 LEDs** providing information about the transformer's status.
- **2 RJ45** connection and power supply ports.

3.- INSTALLATION OF THE DEVICE

3.1.- PRELIMINARY RECOMMENDATIONS



In order to use the device safely, personnel operating it must follow the safety measures that comply with the standards of the country where it is to be installed; operators must wear the required personal protective equipment (rubber gloves, approved facial protection and flame-resistant clothing) to prevent injuries from electric shock or arcs caused by exposure to current-carrying conductors, and they must heed the various warnings indicated in this instruction manual.

The **RDB+** device must be installed by authorised and qualified staff.

The power supply plug must be disconnected and measurement systems switched off before handling, altering the connections or replacing the device. It is dangerous to handle the device while it is powered.

Cables must always be kept in perfect condition to avoid accidents or injury to personnel or installations.

Restrict the operation of the device to the specified measurement category, voltage or current values.

The manufacturer of the device is not responsible for any damage resulting from failure by the user or installer to heed the warnings and/or recommendations set out in this manual, nor for damage resulting from the use of non-original products or accessories or those made by other manufacturers.

Do not use the device to take any measurements if an anomaly or malfunction is detected.

Check the surrounding environment before starting to take measurements. Do not take any measurements in hazardous or explosive environments.



Before carrying out maintenance, repair or handling of any of the device's connections, the device must be disconnected from all power sources, both from the device's own power supply and the measurement's.

Contact the after-sales service if you detect that the device is not working properly.

3.2.- INSTALLATION



When the device is on, its terminals, opening covers or removing elements may expose the user to parts that are hazardous to touch. Do not use the device until it is fully installed.

The device must be installed inside a medium or low voltage electric panel or enclosure, with DIN rail mounting (IEC 60715).



The device has a LED (CPU) that indicates voltage presence. Even in the case that the aforesaid LED is off, the user still needs to check the device is disconnected from any power supply.

The device must be connected to a power circuit protected by a fuse according to its power and consumption rating. It must be fitted with a circuit-breaker or equivalent device to disconnect the device from the power supply.

3.3.- PANEL ADAPTER 72 x 72 mm

Note: The 72 x 72 mm panel adapter is a separately sold accessory.

VMC has a panel adapter for RDB+ devices so that it can be installed on 72 x 72 mm panels.

Figure 1 illustrates how the panel adapter is connected to an RDB+.



Before installing the adapter, the device must be disconnected from all power and measurement supplies.

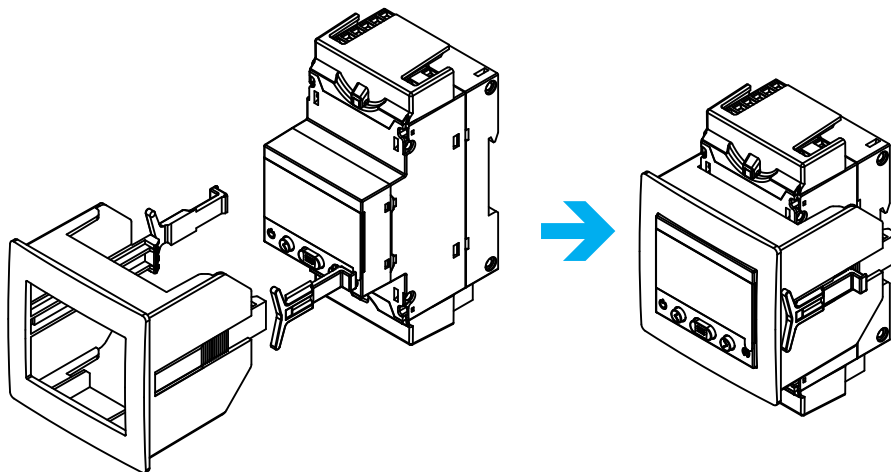

Figure 1: Installation of the panel adapter.

Table 3: Technical characteristics of the Panel Adapter.

Technical Specifications	
Protection degree	IP40
Enclosure	Self-extinguishing V0 plastic

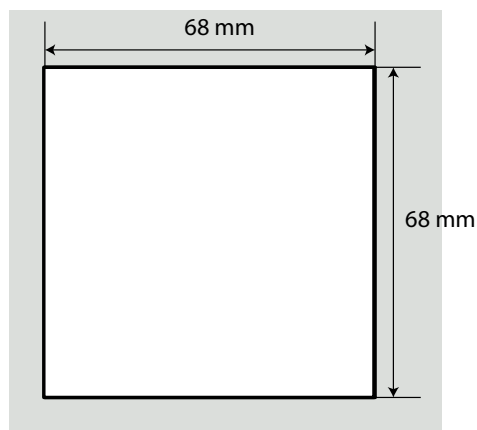

Figure 2: Cut in the panel.

3.4.- DEVICE TERMINALS

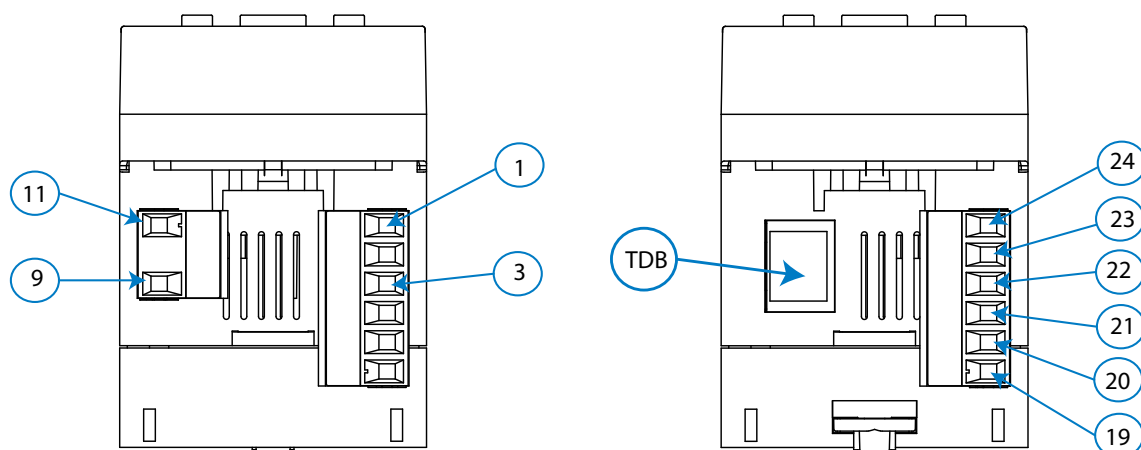

Figure 3: Terminals of the RDB+: Upper - Lower.

Table 4: List of RDB+ terminals.

Device terminals	
9: A1 +, Power supply	21: TRIP, Digital input for external trigger
11: A2 -, Power supply	22: GND for RS-485 and Digital input TRIP
1: R1, Output relay channel 1 (NO)	23: B-, RS-485
3: C1, Output relay channel 1 (Common)	24: A+, RS-485
19: Prealarm, Digital output (NO)	TDB: TDB transformer Connection
20: Prealarm, Digital output (Common)	

3.5.- TDB TRANSFORMERS



When the device is on, its terminals, opening covers or removing elements may expose the user to parts that are hazardous to touch. Do not use the device until it is fully installed.

The transformer is designed for wall-mounting or DIN-rail assembly with an accessory for installation.

The **TDB** is a feed-thru busbar type transformer, where the conductor cables to be measured must pass through the inner hole or window of the transformer.

3.5.1. PANEL INSTALLATION

For panel installation, 4 clamping clips, are provided with the transformer, see **Figure 4**.

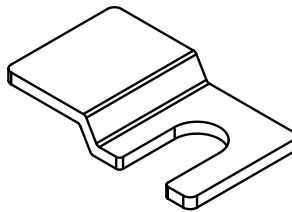

Figure 4: Clamping clip.

The clamping clips which must be installed on the **TDB** as shown in **Figure 5**.

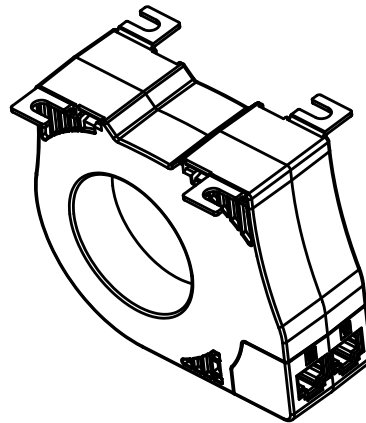

Figure 5: Position of the clamping clips.

3.5.2. INSTALLATION ON A DIN RAIL

For installation on a DIN rail, a support bracket is provided with the device, see Figure 6.

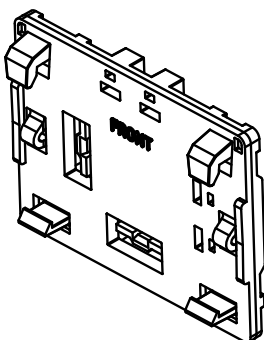

Figure 6: Support bracket.

The steps to ensure proper installation are:

- 1.- Attach the bracket to the DIN rail. Be sure the side marked FRONT is visible. The bracket can be installed in 2 ways, depending on how the TDB is to be positioned, Figure 7.
- 2.- Mount the TDB on the bracket, Figure 7.

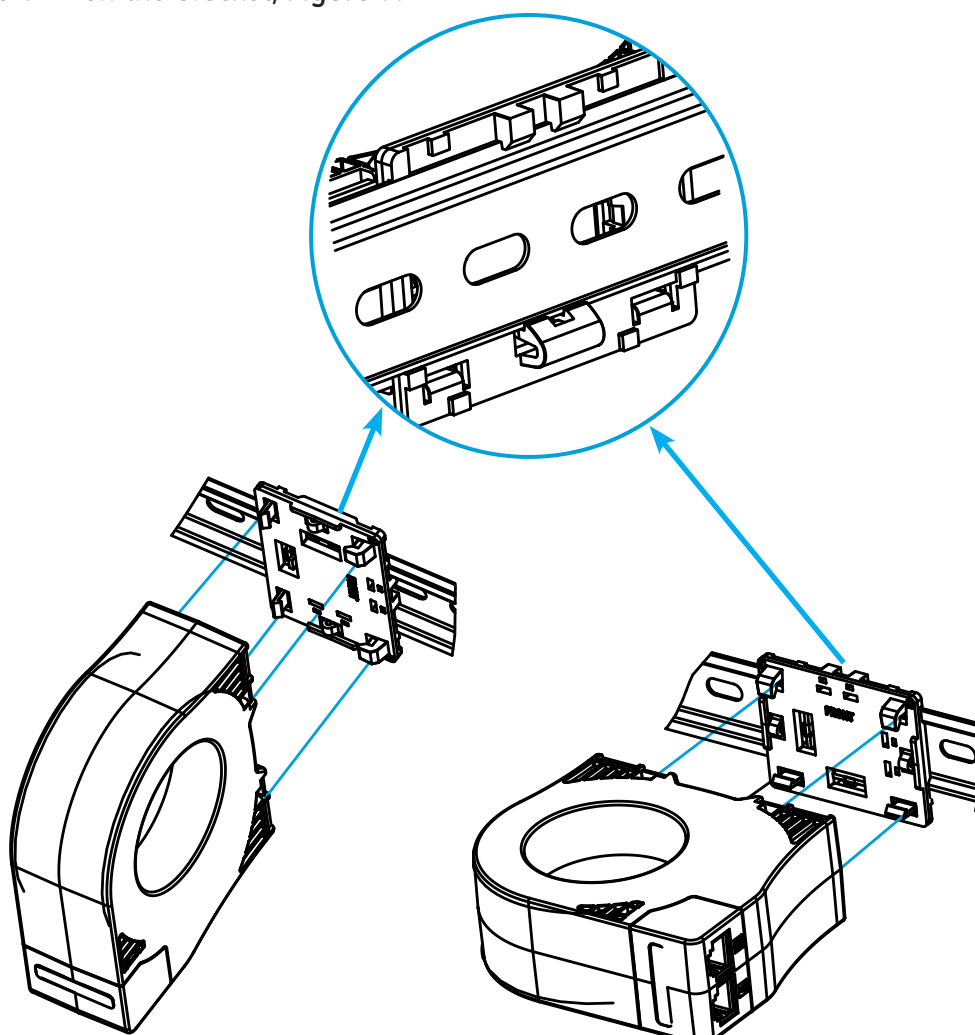

Figure 7: Installation on a DIN rail.

Note: To remove the bracket from the DIN rail, use a screwdriver to pry it off, Figure 8.

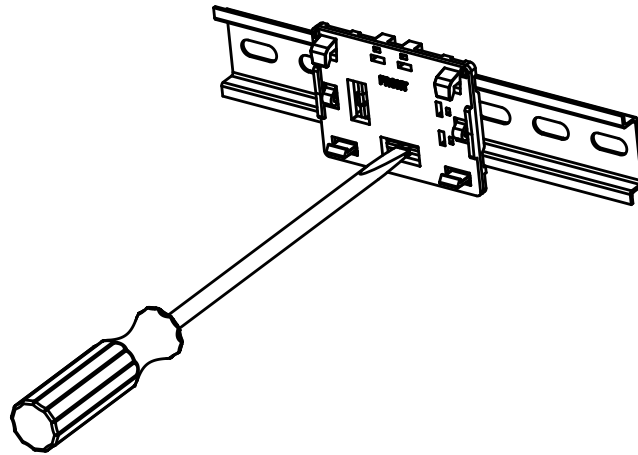

Figure 8: To remove the bracket use a screwdriver.

3.5.3.- TRANSFORMER TERMINALS

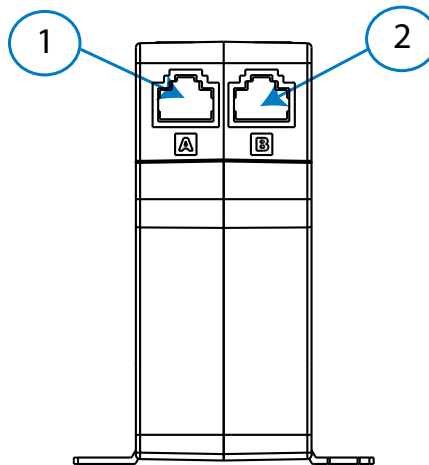

Figure 9: TDB terminals.

Table 5: List of TDB terminals.

Device terminals	
1, 2	Connection terminals to the RDB+

3.5.4.- TRANSFORMER LEDs

TDB transformers have 6 indicating LEDs.

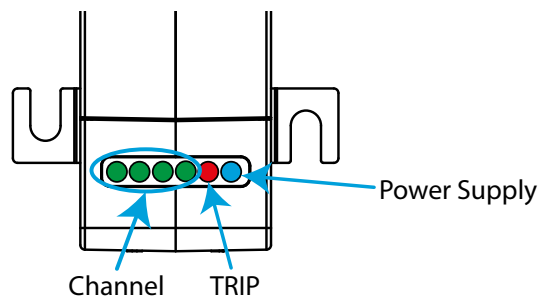



Figure 10: TDB transformer LEDs

- **Power** (Blue color), indicates that the device is supplied power.
- **TRIP:** (Red color), indicates that a leakage current trip has occurred.
(Red blinking), indicates that a prealarm has been generated.
- **Channel** (Green color), indicates the channel used for the **TDB**.

Table 6: Channel LEDs.

LEDs	Description
Channel	 Channel 1

3.6.- CONNECTION DIAGRAMS

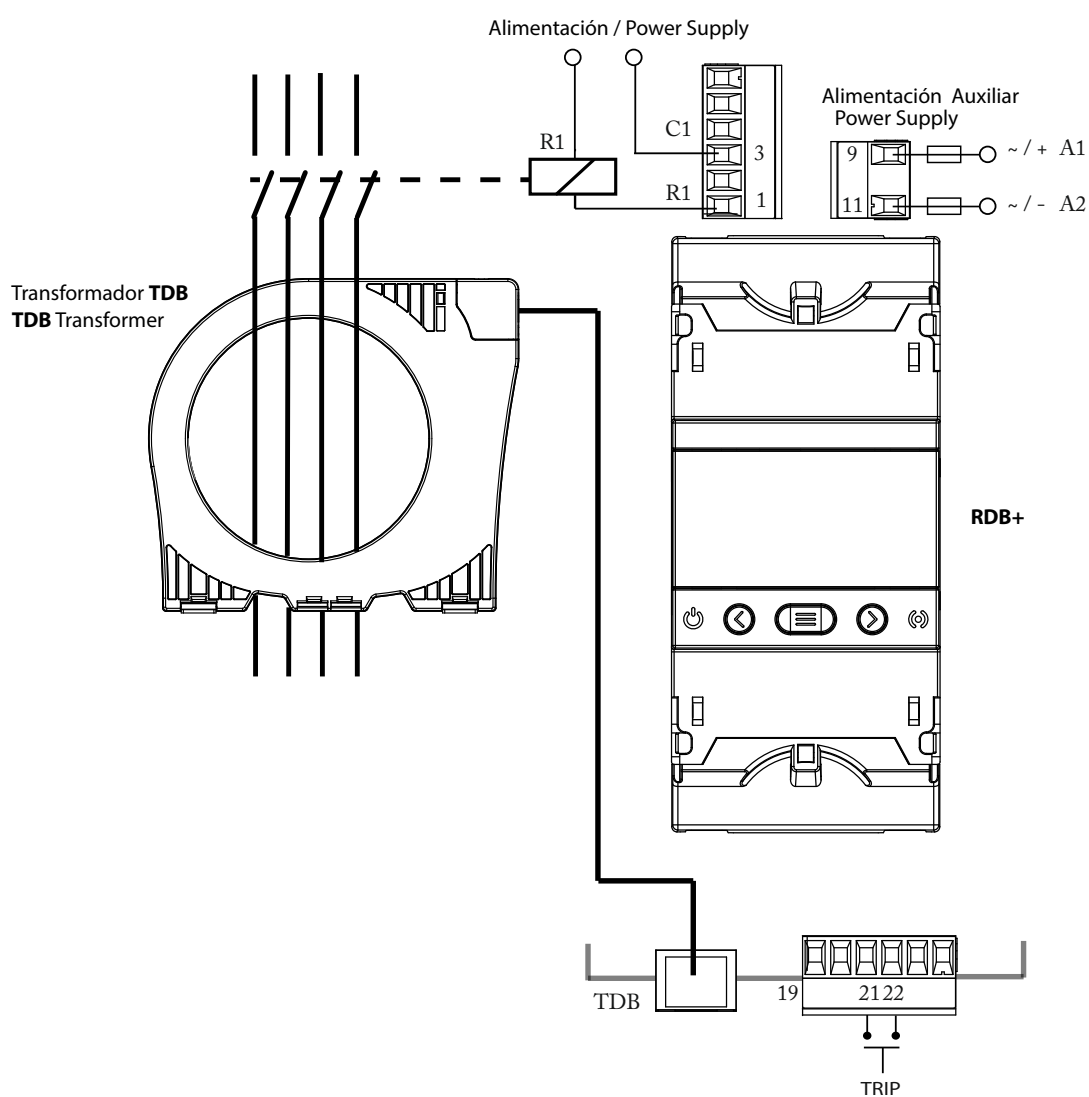

Figure 11: RDB+ Connection diagram.

3.7.- INSTALLATION CONNECTIONS

All active conductors that supply the loads or part of the installation where protection is required must pass through the associated **TDB** transformers.

Connect the **TDB** transformer to the **RDB+** using the RJ45 cable, **Figure 12**.

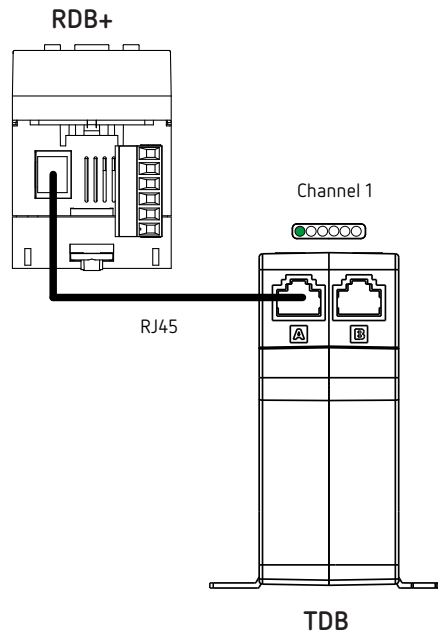

Figure 12: RDB+ - TDB connection.

Note: If a RJ45 connection cable other than the one supplied with the **TDB** is used, it must have a cross-section of 4 x 2 x AWG24/7. The cable must be a maximum length of 9 metres.

Connect the output relay of the **RDB+**.

If the installation is modified and it involves new transformer, a replacement of the **TDB**, the **RDB+** will detect this change and light the screens in yellow, see "5.2.- PROBLEMS OR CHANGES IN THE INSTALLATION".

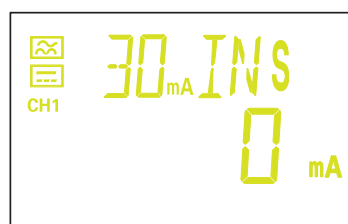

Figure 13: Change in the installation.

4.- OPERATION

4.1.- LED INDICATORS

The **RDB+** device has 2 LEDs:

- **CPU**, white color, indicates that the device is on.
- **ALARM**,

Table 7: ALARM LED.

LED	Description
ALARM	Red blinking:
	Indicates that a prealarm has been generated.
	Red ON:
	Indicates that a trip has been generated.

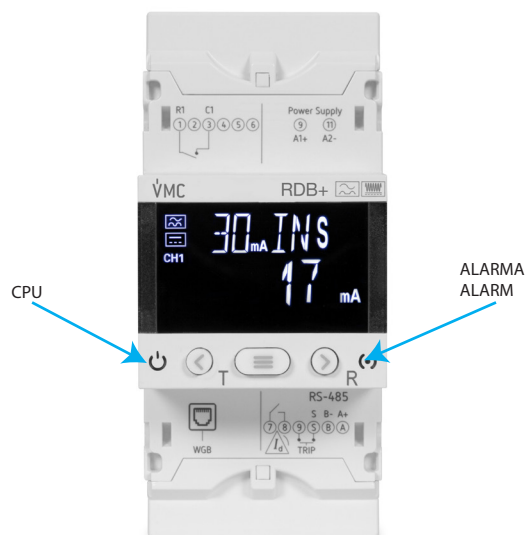

Figure 14: RDB+ LED indicators.

4.2.- DISPLAY

The device has a backlit LCD display that is split into two areas (Figure 15):

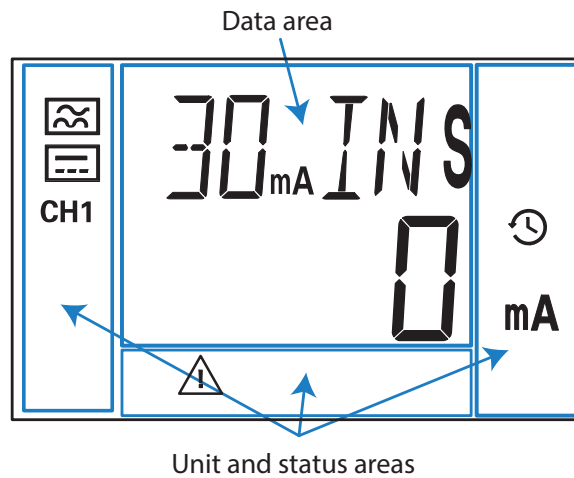

Figure 15: RDB+ display areas.

- ✓ The **data area**, which displays all the values measured by the device.
- ✓ The **unit and device status area**, which displays the different statuses, units and device information (Table 8).

Table 8: Display icons.

Icon	Description	Icon	Description
	Alternating current		Prealarm activated
	Direct current		The device clock has not been set up
CH1	Channel: CH1 channel 1	trip	A trip has been generated
prog	Programming screen		Programming menu: Locked with a password. Unlocked.
	Internal device error, contact SAT		

The device's display can change color, indicating:

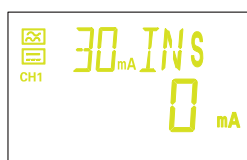

Yellow color:

The installation has changed, see "**5.2.- PROBLEMS OR CHANGES IN THE INSTALLATION**".

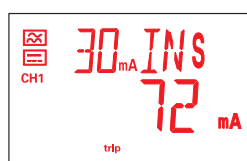

Red color:

The relay has tripped due to leakage current, see "**5.4.- TRIP DISPLAY SCREENS**".



An Individual test has been carried out, see "**5.5.- TEST SCREEN**".
An error was detected in the TDB.

4.3.- KEYBOARD FUNCTIONS

The **RDB+** has 3 keys to browse through the different screens and program the device.

Function of the keys (**Table 9**):

Table 9: Function of the keys on display screens.

Key	Short keystroke	Long keystroke (3s)
	Previous screen	Performs a TEST on the channel
	Next screen	If tripped, the channel's relay is RESET
	-	Access to the direct settings, the setup menu or the event menu, depending on the screen being displayed.

4.4.- DIGITAL OUTPUT

The device has a digital output (terminals 19 and 20 of **Figure 3**) that is activated when a prealarm is generated, see "**6.2.- PREALARM**".

4.5.- RELAY

The **RDB+** has 1 output relay (terminals 1 and 3 of **Figure 3**) to carry out a trip on the channel. See "**5.6.- DIRECT SETTINGS**" to configure the trip parameters.

4.6.- DIGITAL INPUT

The device has a digital input, **TRIP**, (terminals 21 and 22 of **Figure 3**) to carry out a trip.

5.- DISPLAY

When starting the device, the initial screen is displayed, showing the version of the device, **Figure 16**, and after 3 seconds, the clock setup menu appears.

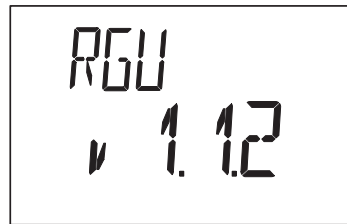

Figure 16: Initial Screen.

5.1.- CLOCK SETUP MENU

Each time the device is switched on, the current date and time has to be configured. If no key is pressed for 60 seconds, the device goes to the main display screen without updating the date and time. The display screen shows the icon ⌚, indicating that the **RDB+** clock has not been configured.

Figure 17 shows the year setup screen.

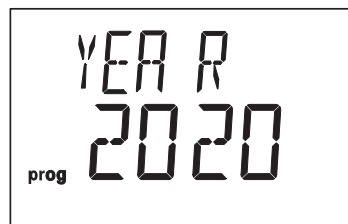

Figure 17: Clock setup: Year.

Press key > to increase the year value, and key < to reduce it.

Press key ≡ to confirm the value and skip to the month configuration screen, **Figure 18**.

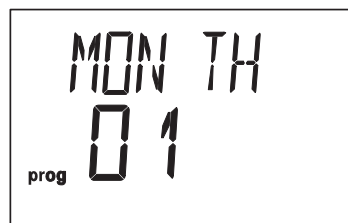

Figure 18: Clock setup: Month.

Press key > to increase the month value, and key < to reduce it.

Press key ≡ to confirm the value and skip to the day configuration screen, **Figure 19**.

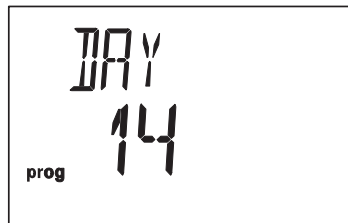



Figure 19: Clock setup: Day.

Press key  to increase the day value, and key  to reduce it.

Press key  to confirm the value and skip to the hour configuration screen, Figure 20.

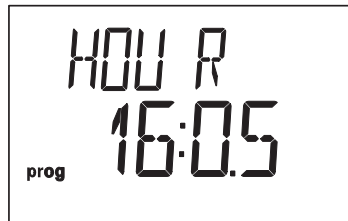







Figure 20: Clock setup: Time.

Press key  to increase the hour value, and key  to reduce it. Press key  to confirm the value and configure the minutes, pressing the keys  and .

Press key  to end the configuration; the screen in Figure 21 is displayed for 3 seconds.

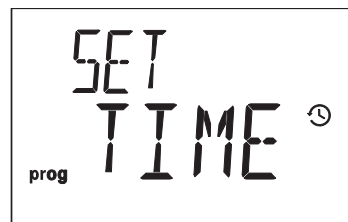
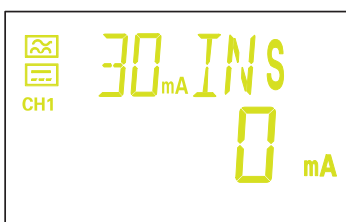

Figure 21: Clock setup: Setup completed.

5.2.- PROBLEMS OR CHANGES IN THE INSTALLATION

If the device detects a problem in the installation when the clock has been set up, the screens will be lit in yellow and one of the following screens will be displayed:



The installation has changed, the new installation has to be saved by accessing the setup menu, see **6.5.1. - SAVE INSTALLATION**".



The installation has changed and the device does not find the TDB.

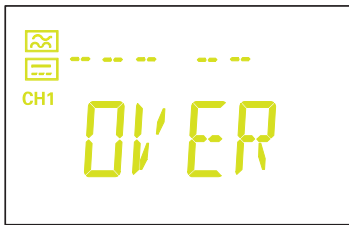

The device has detected more **TDB** transformers than the installation can accept.

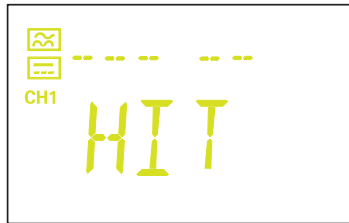

The device has detected **TDB** transformers that are not registered in the installation. The new installation has to be saved; this is carried out accessing the setup menu, see **"6.5.1.- SAVE INSTALLATION"**.

5.3.- DISPLAY SCREENS

The display screen shows the leakage current and the trip current and delay values of the channel, Figure 22.

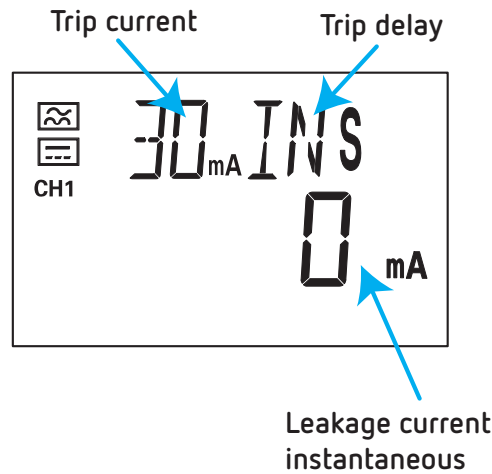
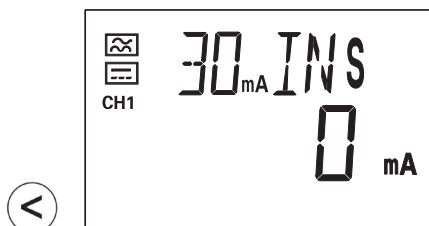
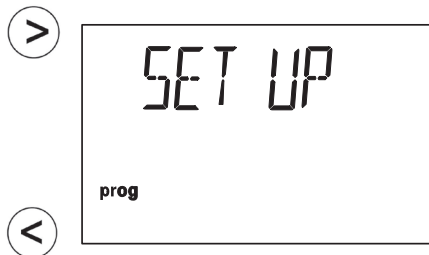

Figure 22: Display screen.

Use keys and to browse through the different screens:



Channel 1:
 Trip current (mA)
 Trip delay
 Total leakage current (alternating + direct), instantaneous (mA)



Access the general setup menu by pressing the key for > 3s.
 (See **"6.- CONFIGURATION"**)
Note: If no key is pressed for 1 minute, the device goes to Channel 1's display screen.



Access the event menu by pressing the key  for > 3s.
(See "5.7.- EVENT MENU")

Note: If no key is pressed for 1 minute, the device goes to Channel 1's display screen.



5.4.- TRIP DISPLAY SCREENS

If a trip has been generated in the channel, the display screen will be displayed in red, the **Alarm** LED will be lit in red and the last cycle current that tripped the relay will be displayed.

Use key  to browse through the different trip information screens:

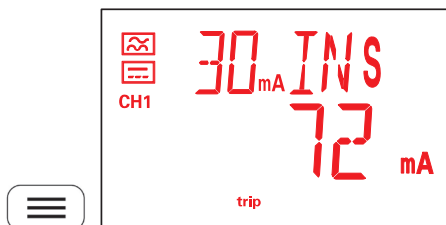

Trip current (mA)
Trip delay
Total leakage current (alternating + direct) that tripped the relay (mA)

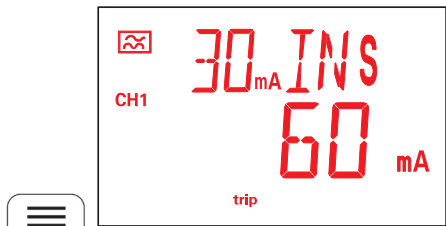

Trip current (mA)
Trip delay
Alternating leakage current that tripped the relay (mA)

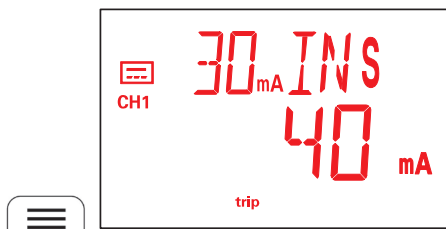

Trip current (mA)
Trip delay
Direct leakage current that tripped the relay (mA)



When pressing key  for > 3s, the relay returns to its initial status and **Figure 23** is displayed for 3s before returning to the channel display screen.



Figure 23: Reset.

5.5.- TEST SCREEN

It is possible to carry out an individual test on the channel to verify the proper functioning of the relay. To do this, press key  for > 3s while channel 1's screen is being displayed.

If the relay has been tripped correctly, the screen in **Figure 24** is displayed. And the **Alarm LED** is lit in red.

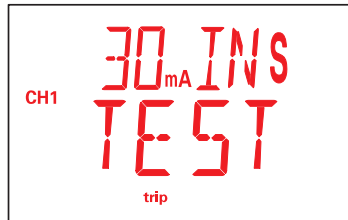

Figure 24: Individual test.

The relay is returned to its idle status by pressing the key  for > 3s; the screen in **Figure 25** is displayed for 3s before returning to the channel display screen.



Figure 25: Reset.

If the trip could not be carried out, the error screen (**Figure 26**) is displayed for 3s before returning to the channel display screen.

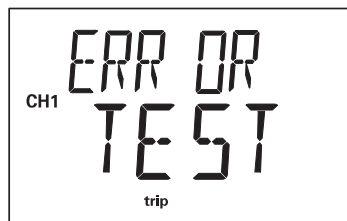

Figure 26: Test Error.

5.6 .- DIRECT SETTINGS

From the channel's display screen, we can configure its trip current and delay.

To do this, press key  for > 3s while the channel's screen is displayed.

Note: In "ANNEX A.- DIRECT SETTINGS" we can see the configuration tree.

5.6.1.- PASSWORD

If the configuration password has been activated (see "6.4.- PASSWORD"), the following screen is displayed to enter the access password.

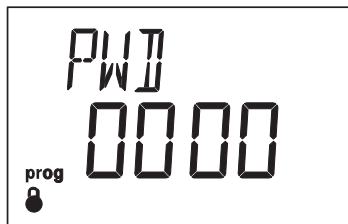

Use keys  and  to modify the digit's value.



Press key  to skip through the digits.

To validate the value and skip to the first programming point, with a long keystroke press .

5.6.2.- TRIP CURRENT

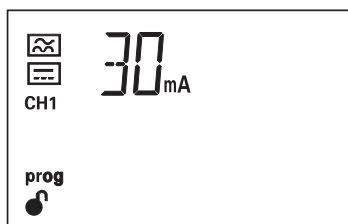
The relay's trip current is configured in this screen.



Use keys  and  to skip through the different options: 30 mA, 100 mA, 300 mA, 500 mA, 1.0 A, 3.0 A.



To skip to the next programming point, press once the key .

Hold down the key  for > 3s, to validate the data and exit the programming.

5.6.3.- DELAY AND RELAY CURVE

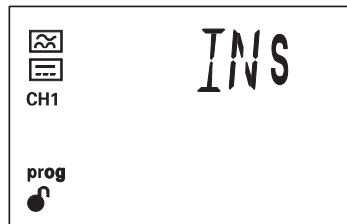
This screen is used to configure the delay of the relay trip or the type of trip curve.



Use keys  and  to skip through the different options:

INS, Curve INS

S, Curve SEL

0.1s, 0.2s, 0.3s, 0.4s, 0.5s, 0.8s, 1s, 3s, 5s, 10s.

Note: If the Trip current is **30 mA**, only the **INS** curve can be programmed.

Note: If the Trip current is **1.0 A** or **3.0 A**, the **INS** and **S** curves cannot be programmed.

To return to the last programming point, press once the key .

Hold down the key  for > 3s, to validate the data and exit the programming.

5.7.- EVENT MENU

To enter the event menu, we must display the Events screen and press the key  for > 3s.



The device displays the last 10 events generated.

The **RDB+** saves 4 different types of events:

TRIP, trip of a channel's relay.

ALA, prealarm activated.

TST, individual test

TRA, error in the transformer.

Use keys  and  to move from one event to another.

Press key  for > 3s, to exit the event menu.

Three screens are displayed for **Prealarm, Test and Error events in the transformer:**

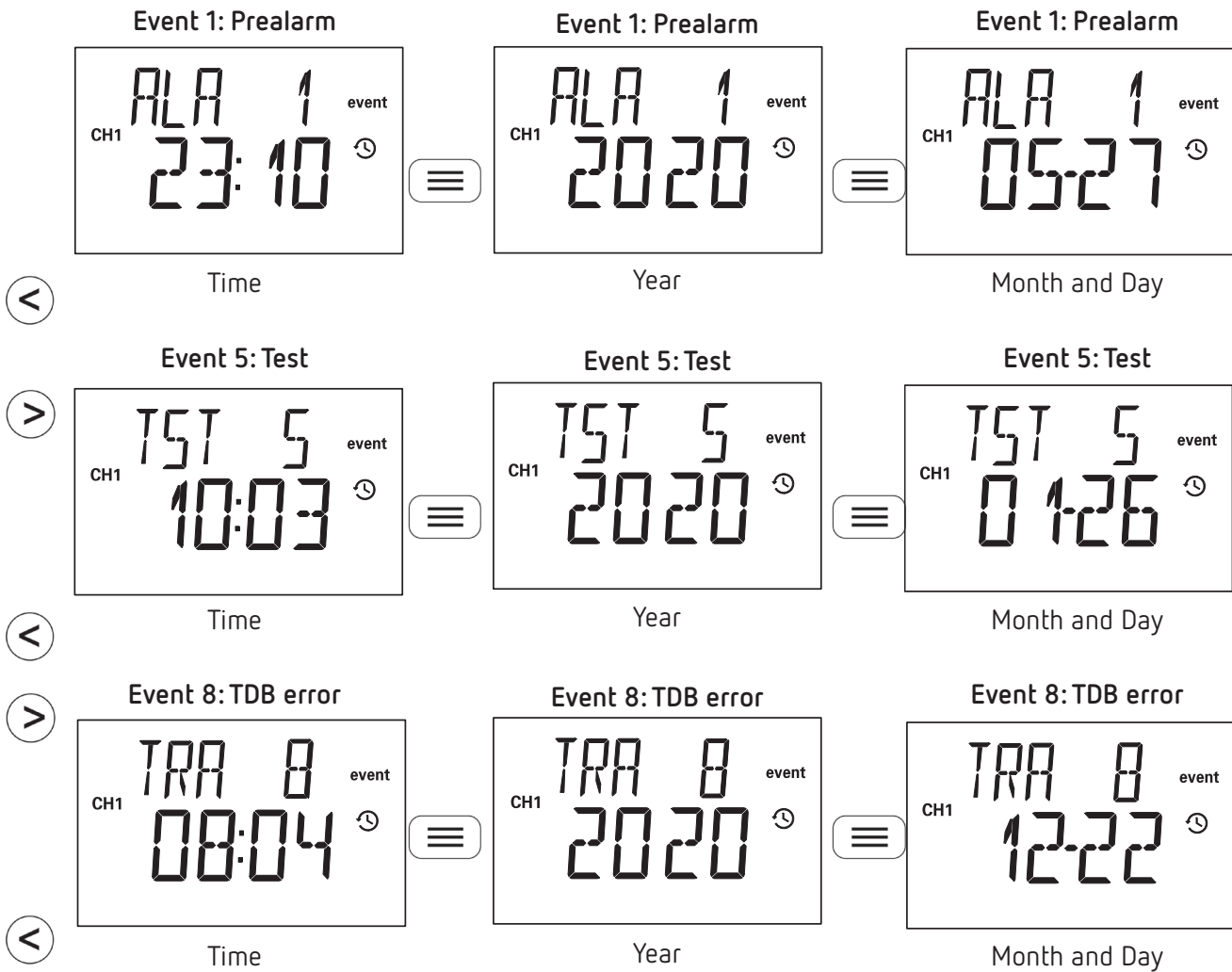

Six screens are displayed for **Trip** events:

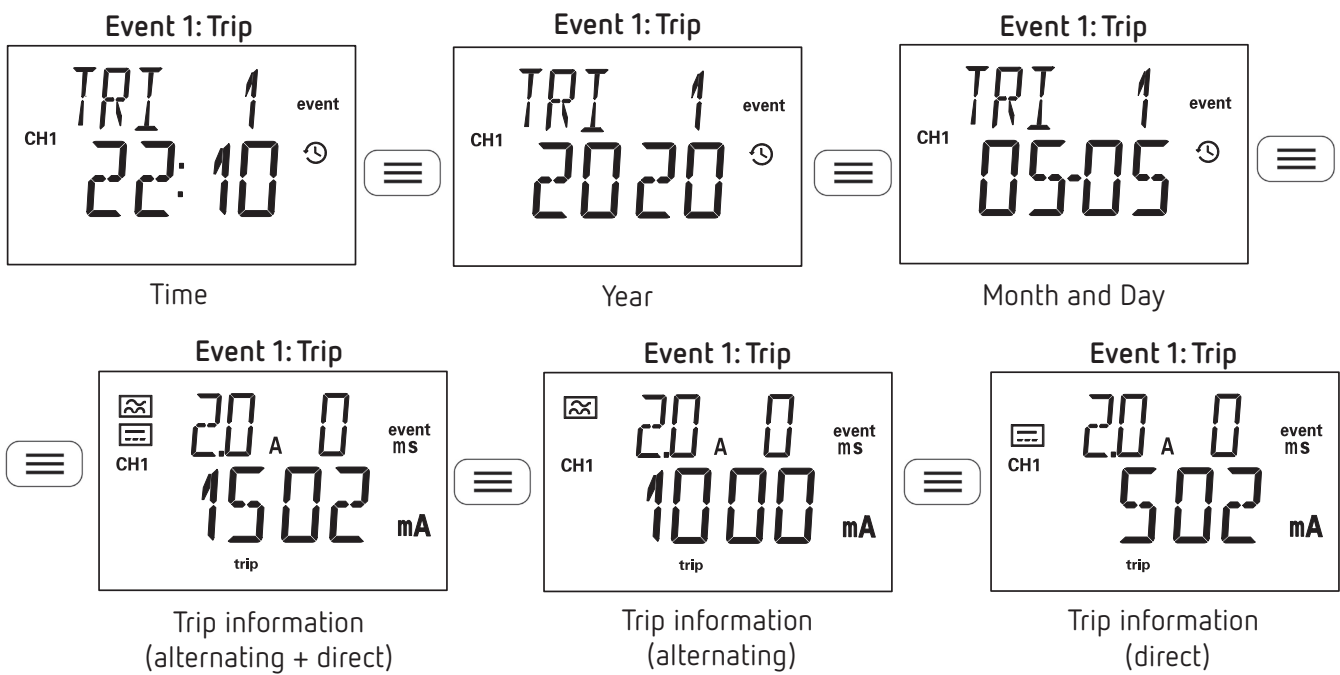

The register of events can be reset by communications, see **"7.3.4 .- EVENTS"**.

5.8.- OTHER SCREENS

While the RDB+ is operating different screens can appear, indicating:

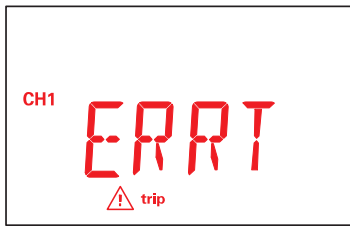

Communication with the TDB has been lost.

6.- CONFIGURATION

To enter the setup menu, we must display the Events screen and press the key  for > 3s.

The RDB+ organises the device's configuration of the equipment into 5 menus, **Figure 27**.

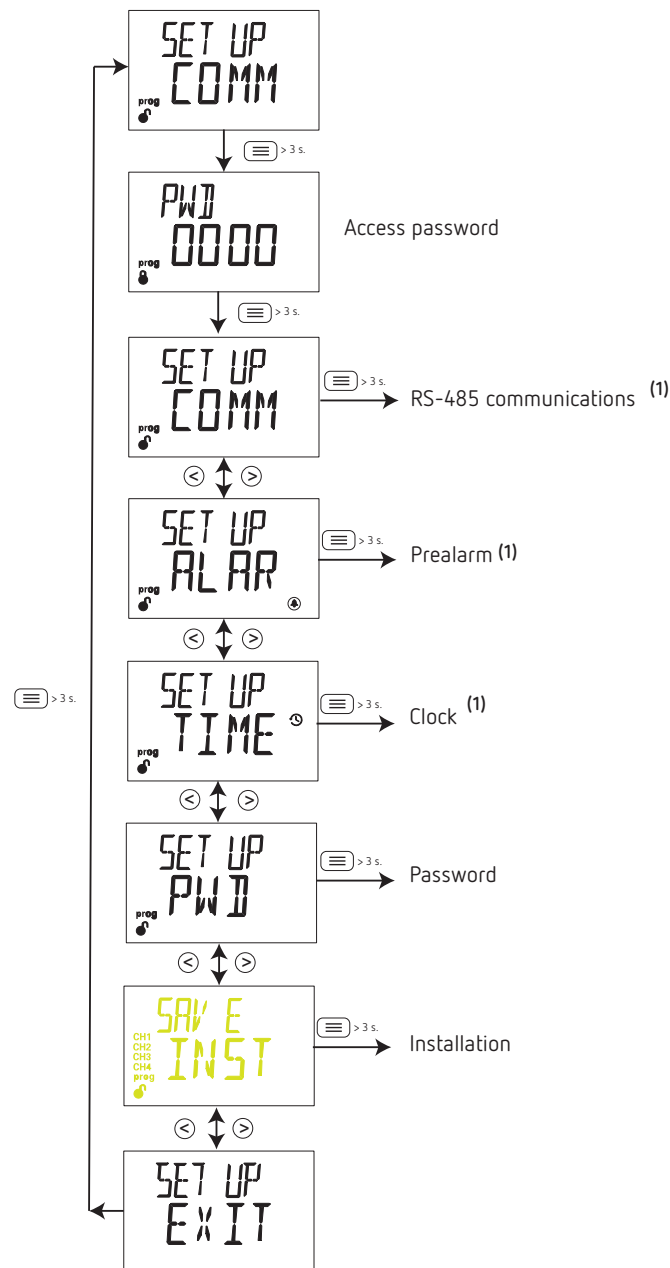

Figure 27: Setup menu.

(1) Menu visible with password locked.

Note: In "ANNEX B.- SETUP MENU" we can see the configuration tree.

The device's setup menu can be protected by password; if it is protected, the screen in **Figure 28** will be displayed when accessing the setup menu.

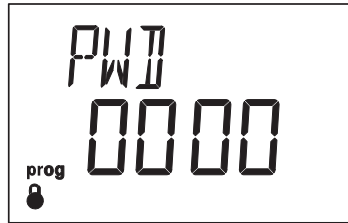





Figure 28: Password Screen.

Use keys  and  to modify the digit's value.

Press key  keys to skip the digit.

To validate the value, hold down the key  for > 3s; if the password is correct, in the bottom left of the display, we can see the icon .

Note: The password can be modified in "6.4.- PASSWORD"

If the password is not entered or the one entered is incorrect, in the bottom left of the display, we can see the icon , and only the clock setup menu can be modified. Some of the other menus will be visible and others not.

6.1.- RS-485 COMMUNICATIONS

Figure 29 shows the initial screen of the RS-485 communications menu. Press the key  for > 3s, to access the menu.



Figure 29: Communications menu.

6.1.1.-BAUD RATE

In this screen, the baud rate of the RS-485 communications is set up.

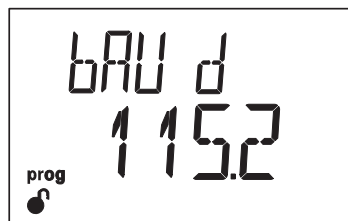

Use keys  and  to skip through the different options:

4.8 (4800), 9.6 (9600), 19.2 (19200), 38.4 (38400), 57.6 (57600), 115.2 (115200) bps

To skip to the next programming point, press once the key .

Hold down the key  for > 3s, to validate the data and exit the programming.

6.1.2.- PERIPHERAL NUMBER

This screen enables peripheral number configuration.

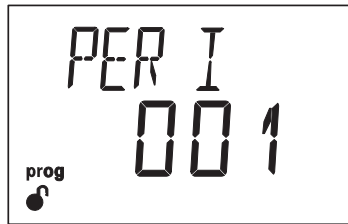

Use keys  and  to modify the value.

Minimum value: 1.

Maximum value: 247.



To skip to the next programming point, press once the key .

Hold down the key  for > 3s, to validate the data and exit the programming.

6.1.3.- DATA FORMAT

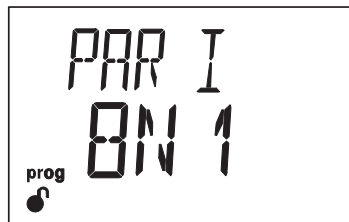
This screen is used to configure the data format.



Use keys  and  to skip through the different options:

8N 1, 8 data bits, no parity, 1 stop bit.

8E 1, 8 data bits, even parity, 1 stop bit.

8O 1, 8 data bits, odd parity, 1 stop bit.

8N 2, 8 data bits, no parity, 2 stop bits.

8E 2, 8 data bits, even parity, 2 stop bits.

8O 2, 8 data bits, odd parity, 2 stop bits.

To skip to the next programming point, press once the key .

Hold down the key  for > 3s, to validate the data and exit the programming.

6.2.- PREALARM

Figure 30 shows the initial screen of the prealarm menu. Press the key  for > 3s, to access the menu.

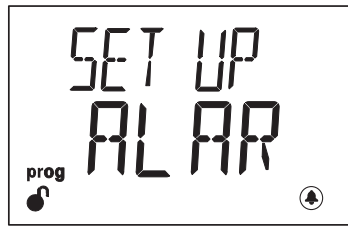

Figure 30: Prealarm menu.

In this menu we can configure the device's prealarm.

6.2.1.- PREALARM CURRENT

This screen is used to configure the current at which the prealarm will be activated according to the % of the relay's trip current.



Use keys  and  to modify the value.

Minimum value: 1%.

Maximum value: 100%.



To skip to the next programming point, press once the key .

Hold down the key  for > 3s, to validate the data and exit the programming.

6.2.2.- PREALARM OPERATION

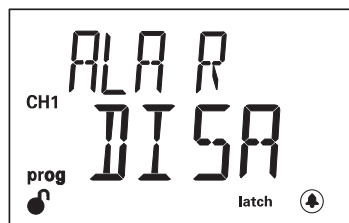
This screen is used to configure the prealarm's operation.



Use keys  and  to skip through the different options:

DISA, prealarm deactivated.

AUTO, prealarm activated with latch deactivated; if the condition for the prealarm disappears, the prealarm is disconnected.

MANU, prealarm activated with latch activated; the prealarm disappears when resetting via the keyboard or communications (see "7.3.3.- TRIPPING DUE TO TEST OR COMMUNICATIONS").

To skip to the next programming point, press once the key .

Hold down the key  for > 3s, to validate the data and exit the programming.

6.3.- CLOCK SETUP



Figure 31 shows the initial screen of the setup menu. Press the key  for > 3s, to access the menu.



Figure 31: Clock setup menu.

See section "5.1.- CLOCK SETUP MENU" to set up the device's clock.

6.4.- PASSWORD

Figure 32 shows the initial screen of the password configuration menu. Press the key  for > 3s, to access the menu.

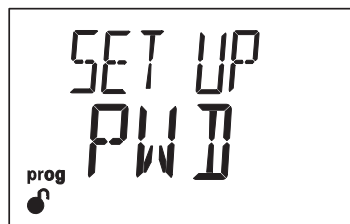
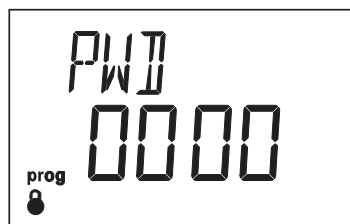



Figure 32: Password configuration menu.

6.4.1.- PASSWORD

This screen is used to configure the password to access the configuration menus.



Use keys  and  to modify the digit's value.

Press key  to skip through the digits.

To validate the value, with a long keystroke (>3s), press .

Note: If value 0000 is configured, the device deactivates the configuration password.

6.5.- INSTALLATION

Note: Visible menu if the installation has been changed.

Figure 33 shows the initial screen of the installation menu. Press the key  for > 3s, to access the menu.



Figure 33: Installation menu.

6.5.1.- SAVE INSTALLATION

If the installation of the RDB+ has been modified, i.e. the TDB transformer has been replaced (see "3.7.- INSTALLATION CONNECTIONS"), the following screen appears to save the current configuration.

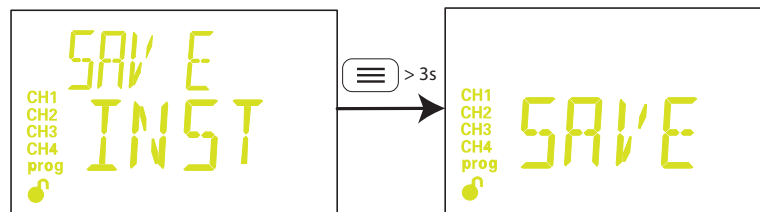

To save the installation, with a long keystroke (>3s), press . The screens are no longer yellow.

6.6.- MENU EXIT

Setup menu exit screen:

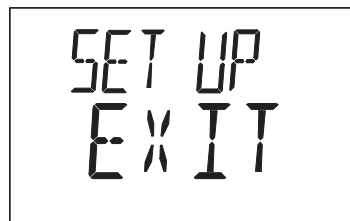

Hold down the key  for > 3s, to exit the setup menu.

7.- RS-485 COMMUNICATIONS

The **RDB+** has an RS-485 communications port. The device is equipped with the **MODBUS RTU** communication protocol as standard.

7.1.- CONNECTIONS

The RS-485 cable must be wired using twisted pair cable with mesh shield (minimum 3 wires), with a maximum distance of 1200 meters between the **RDB+** and the master unit.

In this bus we can connect a maximum of 32 **RDB+**.

For communication with the master unit, we must use a smart RS-232 to RS-485 network protocol converter.

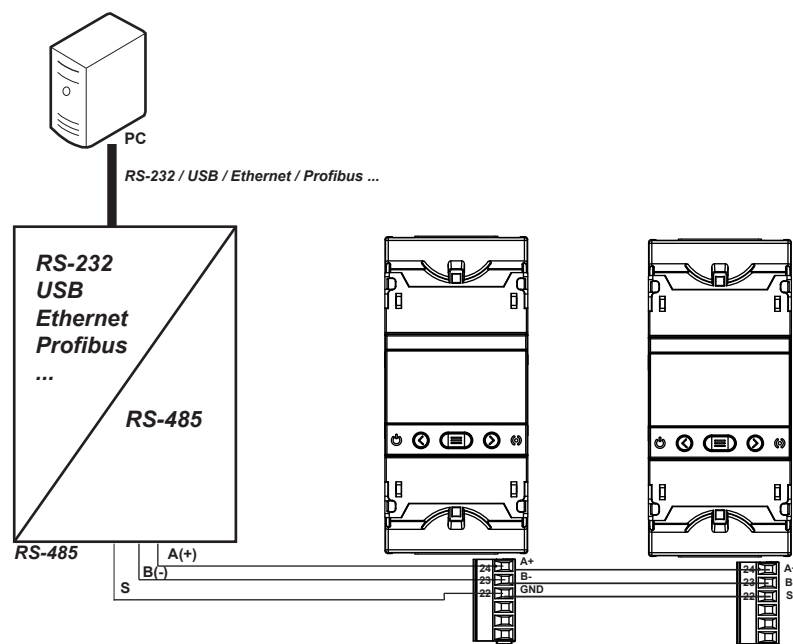

Figure 34: RS-485 connection diagram.

Note: Default values of the RS-485 communication: **9600 bps, no parity, 8 data bits and 1 stop bit.**

7.2.- MODBUS PROTOCOL

Within the Modbus protocol, the **RDB+** uses the RTU (Remote Terminal Unit) mode. The Modbus functions implemented in the device are as follows:

Function 0x01: Reading a relay.

Function 0x02: Reading input status.

Functions 0x03 and 0x04: Reading integer registers.

Function 0x05: Writing a relay.

Function 0x10: Writing multiple registers.

7.3.- MODBUS COMMANDS

All **MODBUS** map addresses are in Hexadecimal format.

7.3.1.- VARIABLES OF THE RDB+ AND INSTALLATION

Function **0x02** is used for these variables.

Functions **0x01** and **0x05** are used for the variable *Save the new installation*.

Table 10: Modbus Memory Map: RDB+ - INSTALLATION (Table 1).

RDB+ - INSTALLATION			
Parameter	Format	Address	Value
Installation tripped due to TRIP input	bool	5DC	0: Not tripped - 1: Tripped
The installation has changed	bool	7CE	0: Not changed - 1: Changed
Internal error detected in the RDB+	bool	7CF	0: Not detected - 1: Detected
Save the new installation	bool	F9F	1: Save the installation

Function **0x04** is used for these variables.

Table 11: Modbus Memory Map: RDB+ - INSTALLATION (Table 2).

RDB+ - INSTALLATION			
Parameter	Format	Address	Value
Date and time of the device	Unit [32]	283C - 283D	Device date (Epoch format)
Serial no. of the TDB registered in the installation's Channel	String	3458 ...345E	-
Installation status	Unit [16]	3583	0... 5 (see Table 12)
Status of RDB+	Unit [16]	3584	0... 2 (see Table 13)
ID no. of RDB+	Unit [32]	35E8-35E9	-
Serial no. of RDB+	Unit [16]	364C... 3652	-

Possible installation statuses, Table 12:

Table 12: Installation statuses.

Possible installation statuses	
Value	Description
0	Correct installation
1	A new TDB has been detected and added to the installation
2	The TDB registered in the installation is not detected
3	A TDB not registered in the installation has been detected
4	More TDB 's than the installation can accept has been detected
5	There is no TDB registered in the installation

Possible statuses of **RDB+**, Table 13:

Table 13: Status of RDB+.

Possible statuses of RDB+	
Value	Description
0	Device in startup process
1	Device idle
2	Device tripped due to activation of the TRIP input

7.3.2.- CHANNEL VARIABLES

Function 0x04: reading of registers, is used for these variables

Table 14: Modbus Memory Map: Channel variables.

Configuration variable	Format	Address	Units/Format
TDB model	String	FA0-FA1	-
Serial no. of TDB	String	FA2...FA8	-
Firmware version (part 1)	Unit [16]	FA9	-
Firmware version (part 2)	Unit [16]	FAA	-
Firmware version revision	Unit [16]	FAB	-
TDB status	Unit [16]	FAC	0... 6 (see Table 15)
TDB channel	Unit [16]	FAD	1: channel 1
Programmed trip curve or delay	Unit [16]	FAE	ms
Programmed trip current	Unit [16]	FAF	mA
Instant total leakage current	Unit [16]	FB0	mA
Instant alternating leakage current	Unit [16]	FB1	mA
Instant direct leakage current	Unit [16]	FB2	mA
Total leakage current that tripped the relay	Unit [16]	FB3	mA
Alternating leakage current that tripped the relay	Unit [16]	FB4	mA
Direct leakage current that tripped the relay	Unit [16]	FB5	mA
Programmed prealarm current	Unit [16]	FB6	%
Prealarm Operation	Unit [16]	FB7	0: Deactivated 1: Activated with deactivated latch 2: Activated with activated latch

Possible statuses of TDB, Table 15:

Table 15: TDB statuses.

Possible statuses of TDB	
Value	Description
0	TDB in startup process
1	TDB in idle status
2	TDB tripped due to detected leakage current
3	TDB tripped due to TEST with Test error result
4	TDB tripped due to TEST with Test successful result
5	TDB tripped due to communications
6	TDB tripped due to TRIP input

Function 0x02 is used for these variables.

Table 16: Modbus Memory Map: Channel status.

Parameter	Format	Address	Value
Internal error detected in the TDB	bool	0000	0: Not detected 1: Detected
Prealarm activated	bool	0001	0: Deactivated 1: Activated
Channel tripped	bool	0002	0: Not tripped 1: Tripped
Channel tripped due to leakage current	bool	0003	
Channel tripped due to error in the TDB	bool	0004	
Channel tripped due to test	bool	0005	
Channel tripped due to TRIP input	bool	0006	
Channel tripped due to communications	bool	0007	
TDB not connected	bool	0008	0: Not detected 1: Detected
TDB does not respond to requests	bool	0009	0: Not detected 1: Detected

7.3.3.- TRIPPING DUE TO TEST OR COMMUNICATIONS

The following functions are used for these variables: **0x01** and **0x05**.

Table 17: Modbus Memory Map: Configuration of the trip and prealarm.

Configuration of the Trip and Prealarm				
Configuration variable	Format	Address	Valid data range	Default value
Tripping due to TEST of channel	bool	07D0	FF00: Activate Test of channel 0000: Finish TEST	0000
Tripping due to Communications of channel	bool	07D1	FF00: Tripping of channel 0000: Channel reset	0000

7.3.4.- EVENTS

The following steps must be taken to read the events:

- 1.- Read the **No. of events in the channel** to consult.
- 2.- Write the channel number to consult in **Channel selection**: 1.
- 3.- Write the event number to consult in **Event selection**.
- 4.- Read the 8 **Event** registers simultaneously to consult the event's details.

Table 18: Modbus Memory Map: Events.

Parameter	Format	Address	Function	Value
No. of events in channel	Unit [16]	13BA	0x04	0... 10
Channel selection	Unit [16]	1388	0x03	1
Event selection	Unit [16]	1389	0x10	1... 10

Table 18 (Continued). Modbus Memory Map: Events.

Parameter	Format	Address	Function	Value
Event	Unit [16]	1388	0x04	Type of event: 0: Tripping of the channel's relay 1: Prealarm activated 2: Individual test 3: Error in transformer
	Unit [16]	1389-138A		Event date (Epoch format)
	Unit [16]	138B		Programmed trip current
	Unit [16]	138C		Programmed trip curve or delay
	Unit [16]	138D ⁽²⁾		Total trip current (alternating + direct)
	Unit [16]	138E ⁽²⁾		Alternating trip current
	Unit [16]	138F ⁽²⁾		Direct trip current
Delete Events	bool	FA0	0x01 0x05	1: Deletes saved events

⁽²⁾ Valid registers when the read event is a relay trip.

7.3.5.- DEVICE CONFIGURATION VARIABLES

The following functions are used for these variables:

Function 0x03: Reading of registers

Function 0x10: Writing multiple registers.

7.3.5.1.- Configuration of the trip and prealarm

Table 19: Modbus Memory Map: Configuration of the trip and prealarm.

Configuration of the Trip and Prealarm				
Configuration variable	Format	Address	Valid data range	Default value
Relay curve or delay ⁽³⁾	Unit [16]	3714	Table 20	0
Trip current ⁽³⁾	Unit [16]	3715	Table 21	30 mA
Prealarm current	Unit [16]	3716	1... 100%	50%
Prealarm Operation	Unit [16]	3717	0: Deactivated 1: Activated with deactivated latch 2: Activated with activated latch	1

⁽³⁾ To programme the relay delay and the trip current, you must first read the possible values of each TDB, which can be found in Table 20.

Table 20: Modbus Memory Map: Relay curve or delay table.

Relay curve or delay table.				
Parameter	Format	Function	Address	Value
Value 1	Unit [16]	0x04	1004	1: Curve INS - 0 ⁽⁴⁾
Value 2	Unit [16]	0x04	1005	2: Curve SEL - 0 ⁽⁴⁾
Value 3	Unit [16]	0x04	1006	100 ms - 0 ⁽⁴⁾
Value 4	Unit [16]	0x04	1007	200 ms - 0 ⁽⁴⁾
Value 5	Unit [16]	0x04	1008	300 ms - 0 ⁽⁴⁾
Value 6	Unit [16]	0x04	1009	400 ms - 0 ⁽⁴⁾
Value 7	Unit [16]	0x04	100A	500 ms - 0 ⁽⁴⁾
Value 8	Unit [16]	0x04	100B	800 ms - 0 ⁽⁴⁾

Table 20 (Continued): Modbus Memory Map: Relay curve or delay table.

Relay curve or delay table.				
Parameter	Format		Address	Value
Value 9	Unit [16]	0x04	100C	1000 ms - 0 ⁽⁴⁾
Value 10	Unit [16]	0x04	100D	3000 ms - 0 ⁽⁴⁾
Value 11	Unit [16]	0x04	100E	5000 ms - 0 ⁽⁴⁾
Value 12	Unit [16]	0x04	100F	10000 ms - 0 ⁽⁴⁾
Value 13	Unit [16]	0x04	1010	0 ⁽³⁾
Value 14	Unit [16]	0x04	1011	0 ⁽³⁾
Value 15	Unit [16]	0x04	1012	0 ⁽³⁾
Value 16	Unit [16]	0x04	1013	0 ⁽³⁾

⁽⁴⁾ 0: Indicates that the value is not available.

Table 21: Modbus Memory Map: Trip current table.

Trip current				
Parameter	Format	Function	Address	Value
Value 1	Unit [16]	0x04	1014	30 mA - 0 ⁽⁵⁾
Value 2	Unit [16]	0x04	1015	100 mA - 0 ⁽⁵⁾
Value 3	Unit [16]	0x04	1016	300 mA - 0 ⁽⁵⁾
Value 4	Unit [16]	0x04	1017	500 mA - 0 ⁽⁵⁾
Value 5	Unit [16]	0x04	1018	1000 mA - 0 ⁽⁵⁾
Value 6	Unit [16]	0x04	1019	3000 mA - 0 ⁽⁵⁾
Value 7	Unit [16]	0x04	101A	0 ⁽⁴⁾
Value 8	Unit [16]	0x04	101B	0 ⁽⁴⁾
Value 9	Unit [16]	0x04	101C	0 ⁽⁴⁾
Value 10	Unit [16]	0x04	101D	0 ⁽⁵⁾
Value 11	Unit [16]	0x04	101E	0 ⁽⁵⁾
Value 12	Unit [16]	0x04	101F	0 ⁽⁵⁾
Value 13	Unit [16]	0x04	1020	0 ⁽⁵⁾
Value 14	Unit [16]	0x04	1021	0 ⁽⁵⁾
Value 15	Unit [16]	0x04	1022	0 ⁽⁵⁾
Value 16	Unit [16]	0x04	1023	0 ⁽⁵⁾

⁽⁵⁾ 0: Indicates that the value is not available.

7.3.5.2.- RS-485 communications

Table 22: Modbus Memory Map: SR-485 Communications.

RS-485 Communications				
Configuration variable	Format	Address	Valid data range	Default value
Peripheral number	Unit [16]	36B0	1... 247	1
Baud rate	Unit [32]	36B1 - 36B2	4800, 9600, 19200, 38400, 57600, 115200	9600
Data format	Unit [16]	36B3	0: 8N1, 1: 8E1, 2: 8O1 3: 8N2, 4: 8E2, 5: 8O2	0

7.3.5.3.- Clock setup

Table 23: Modbus Memory Map: Clock setup.

Clock setup				
Configuration variable	Format	Address	Valid data range	Default value
Clock setup	Unit [32]	283C - 283D	Date and time are given in Epoch format	

7.3.5.4.- Password

Table 24: Modbus Memory Map: Password.



Password				
Configuration variable	Format	Address	Valid data range	Default value
Password	Unit [16]	2A97	0000... 9999 ⁽⁶⁾	0000

⁽⁶⁾ If value 0000 is configured, the device deactivates the configuration password.

8.- TECHNICAL FEATURES

8.1.- RDB+

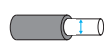
AC Power supply	
Rated voltage	230 V ~ ± 15%
Frequency	50 ... 60 Hz
Consumption	7.5 VA
Installation category	CAT III 300V
Monitoring features	
Rated frequency of the monitored circuit	DC: 0 Hz - AC: 50 Hz - 1 kHz
Rated residual non-operating current	0.5 I _{dn}
Rated conditional short-circuit current (I _{cc})	Depends on the circuit breaker
Rated short-time withstand current (I _{cw})	
Uimp of the voltage source	4 kV (CAT III)
Relay outputs	
Quantity	1
Maximum voltage open contacts	230 V ~
Maximum current	6 A
Maximum switching power	1500 VA
Electrical life (250V ~ / 5A)	60x10 ³ Cycles
Mechanical life	10x10 ⁶ Cycles
Digital output	
Type	Optoisolated
Maximum voltage	230 V ~
Maximum current	0.1 A
Digital input	
Type	Potential free contact
Insulation	5.3 kV
Input impedance	2 KΩ
RS-485 Communications	
Communications protocol	Modbus RTU
Baud rate	4800 - 9600 - 19200 - 38400 - 57600 - 115200 bps
Data bits	8
Stop bits	1 - 2
Parity	without, even, odd
User interface	
Display	LCD custom (negative)
Keyboard	3 keys
LED	2 LED
Environmental features	
Operating temperature	-10°C ... +50 °C
Storage temperature	-20 °C ... +70 °C
Relative humidity (without condensation)	5... 95%
Maximum altitude	2000 m

(Continuation) Environmental features			
Protection degree	IP30, Front: IP65,		
Mechanical features			
			
Terminals: 1, 3, 9, 11, 19... 24	2.5 mm ²	≤ 0.4 Nm, M2.5	Flat
Dimensions	Figure 35 (mm)		
Weight	208 g.		
Enclosure	Self-extinguishing V0 plastic		
Standards			
Low-voltage switchgear. Part 2: Automatic switch protection	IEC 60947-2-M		
General safety requirements for residual current operated protective devices	IEC 60755 ⁽⁷⁾		

⁽⁷⁾ Measurement conditions for Type B waveform specified in IEC 60755.

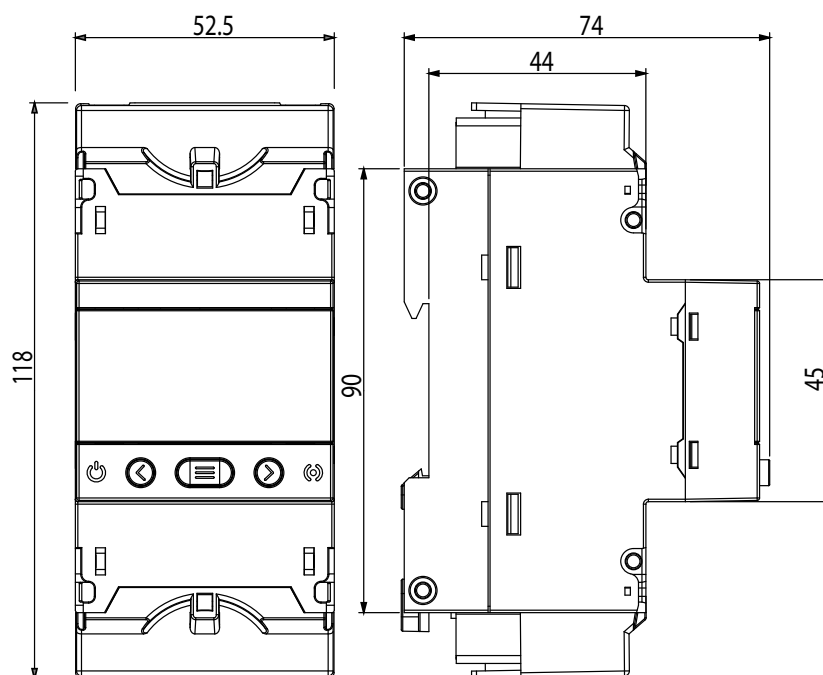

Figure 35: Dimensions of RDB+.

8.2.- TDB

Electrical features				
Models	TDB-35	TDB-55	TDB-80	TDB-110
Type	Bar			
Maximum rated current of the monitored circuit (In)	80 A	160 A	250 A	400 A
Frequency	50... 1 kHz			
Maximum operating voltage	≤ 720 V ~, ≤ 750 V ===			
Accuracy	Tripping current			
	30 mA			± 2 mA
	100 mA			± 5 mA
	300 mA			± 20 mA
	500 mA			
	1.0 A			± 200 mA
	3.0 A			
User interface				
LED	6 LEDs			
Environmental features				
Operating temperature	-10 °C ... +50 °C			
Storage temperature	-20 °C ... +70 °C			
Relative humidity (without condensation)	5... 95%			
Maximum altitude	2000 m			
Thermal class	150 °C			
Mechanical features				
	TDB-35	TDB-55	TDB-80	TDB-110
Window size	∅ 35.5 mm	∅ 55.5 mm	∅ 80.5 mm	∅ 110.5 mm
Weight	235 g.	355 g.	555 g.	750 g.
Enclosure	Self-extinguishing V0 plastic			
Cable from TDB to RDB+				
Connector	RJ45 standard			
Cable cross-section	4 x 2 x AWG24/7			
Temperature range	-20 °C ... +70 °C			
Length ⁽⁸⁾	1.5 m			
⁽⁸⁾ Length of the cable included with the TDB.				
Standards				
Low-voltage switchgear and controlgear - Part 2: Circuit-breakers			IEC 60947-2-M	

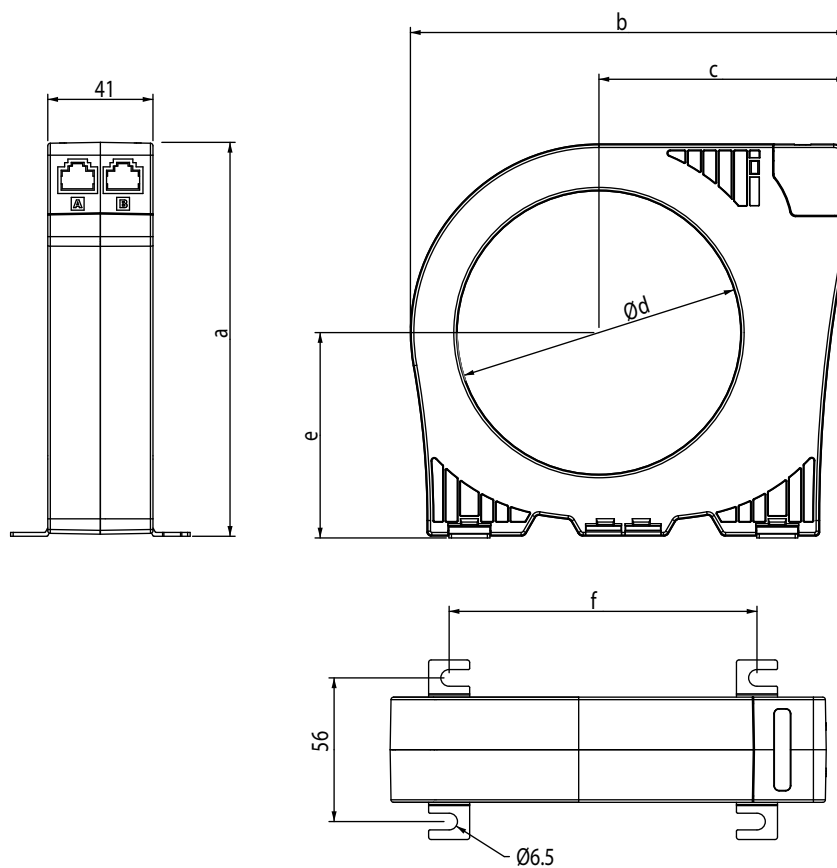

Figure 36: TDB dimensions.

Figure 37: TDB dimensions.

TDB dimensions						
	a	b	c	d	e	f
TDB-35	80	97	61.5	35.5	44.5	54
TDB-55	98.5	118	72	55.5	52.5	81,5
TDB-80	123.5	140	81.5	80.5	65	101.5
TDB-110	153.5	170	96.5	110.5	80	120

9.- MAINTENANCE AND TECHNICAL SERVICE

In the case of any query in relation to device operation or malfunction, please contact the **VMC**, Technical Support Service.

Technical Assistance Service

C/ Montcada 7, Pol. Ind. Les Pereres
08130 - Santa Perpètua de Mogoda (Barcelona)
Tel: (+34) 935 748 206
email: info@vmc.es

10.- GUARANTEE

VMC guarantees its products against any manufacturing defect for two years after the delivery of the units.

VMC will repair or replace any defective factory product returned during the guarantee period.



- No returns will be accepted and no unit will be repaired or replaced if it is not accompanied by a report indicating the defect detected or the reason for the return.
- The guarantee will be void if the units has been improperly used or the storage, installation and maintenance instructions listed in this manual have not been followed. "Improper usage" is defined as any operating or storage condition contrary to the national electrical code or that surpasses the limits indicated in the technical and environmental features of this manual.
- **VMC** accepts no liability due to the possible damage to the unit or other parts of the installation, nor will it cover any possible sanctions derived from a possible failure, improper installation or "improper usage" of the unit. Consequently, this guarantee does not apply to failures occurring in the following cases:
 - Overvoltages and/or electrical disturbances in the supply;
 - Water, if the product does not have the appropriate IP classification;
 - Poor ventilation and/or excessive temperatures;
 - Improper installation and/or lack of maintenance;
 - Buyer repairs or modifications without the manufacturer's authorisation.

ANNEX A.- DIRECT SETTINGS

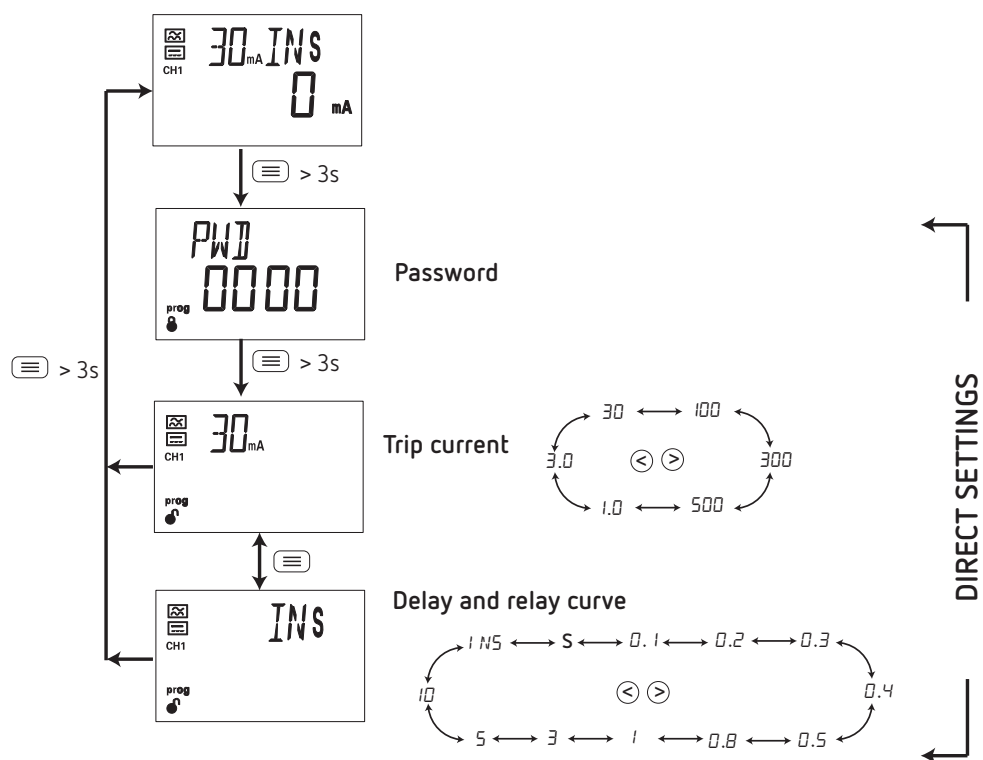

ANNEX B.- SETUP MENU

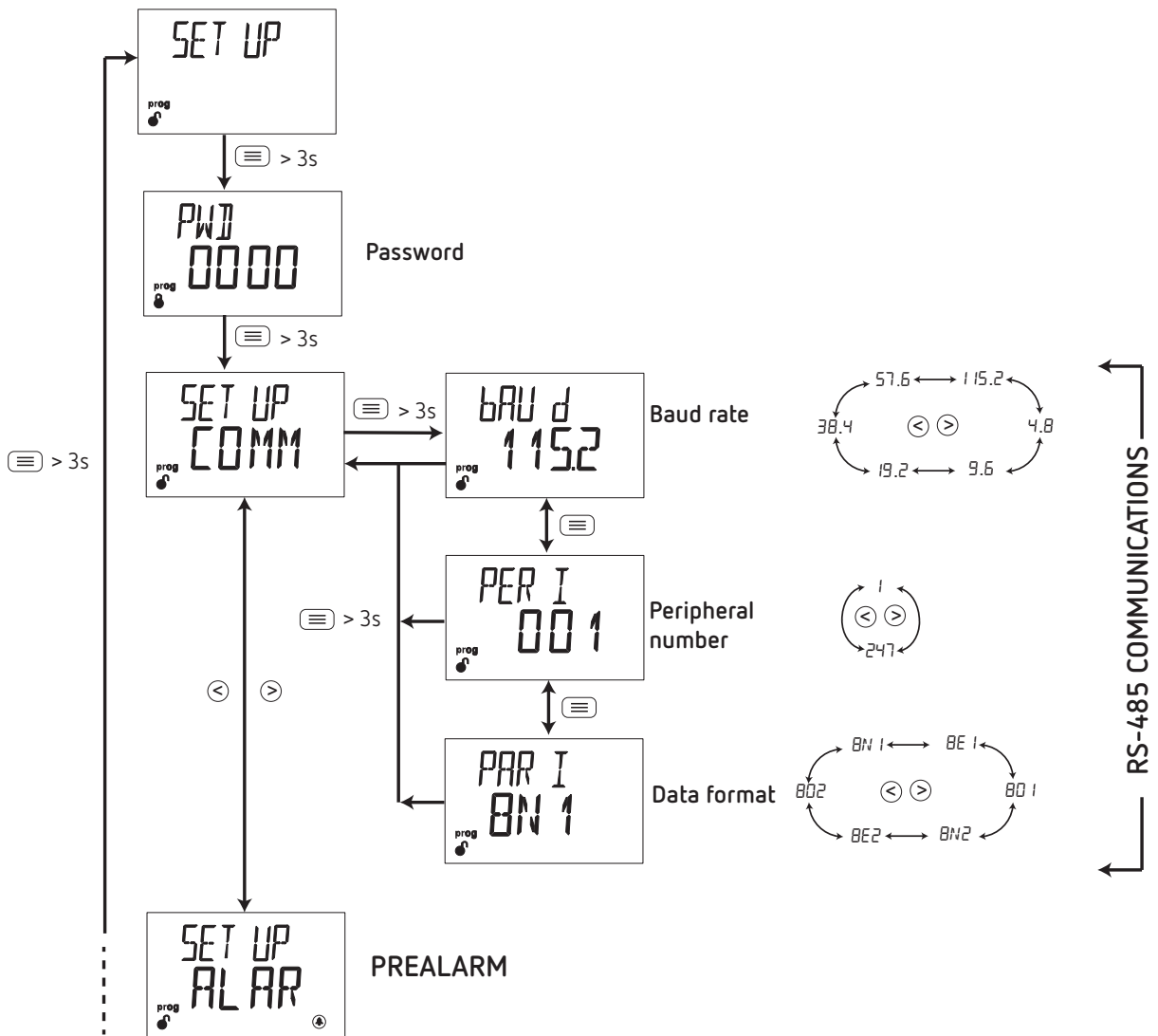

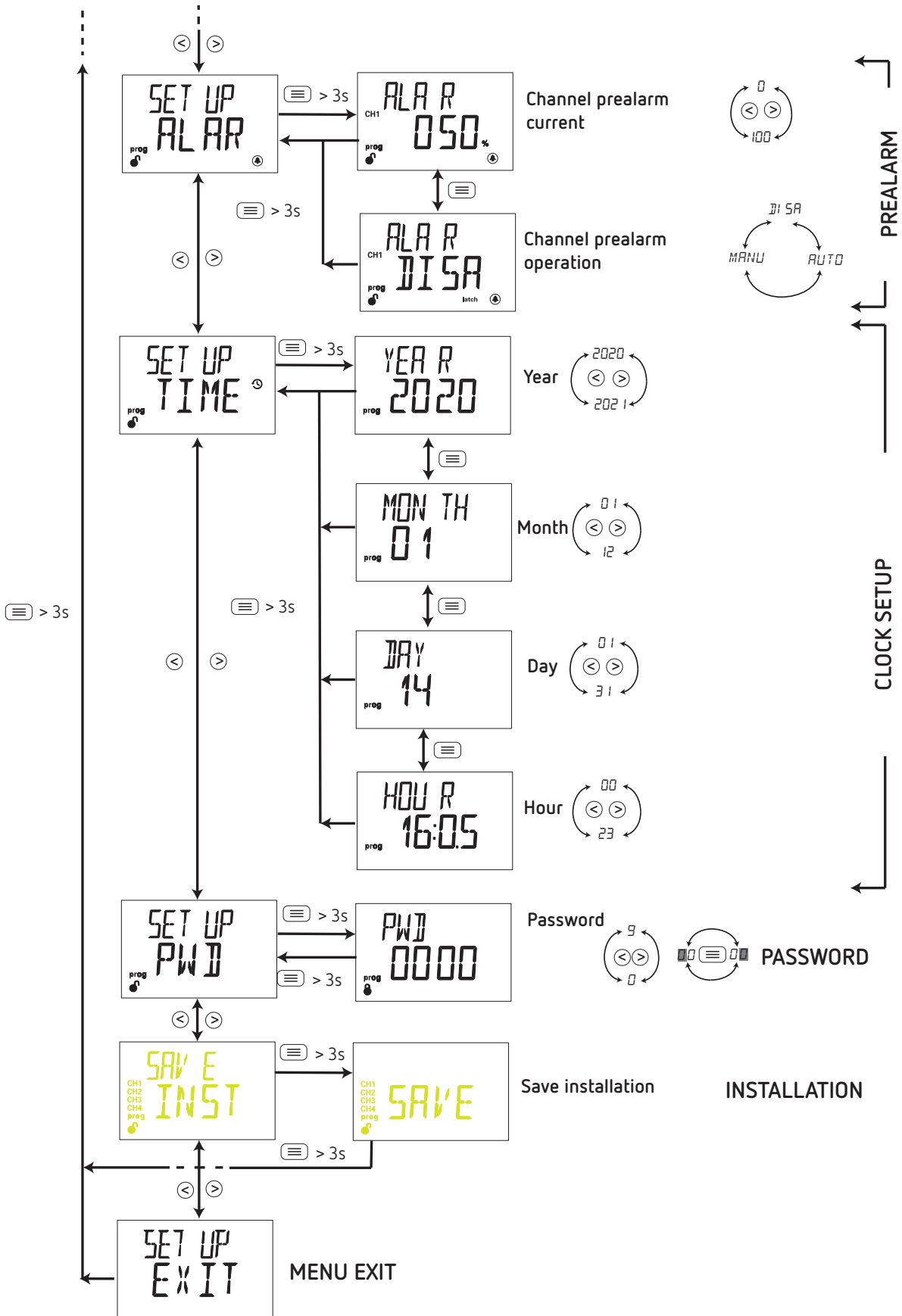

Vector Motor Control (VMC)

C/ Montcada, 7 - Pol. Ind. Les Pereres

08130 - Santa Perpètua de Mogoda (Barcelona)

Tel: (+34) 935 748 206

www.vmc.es info@vmc.es