

Features

- 8, 16, 32, 64 points I/O module
- Operation monitoring by LED display
- Easy maintenance: Terminal block type, one-touch installation of module



Input module specifications

Item	DC input							AC input			
Type	XGI-D21A	XGI-D22A	XGI-D22B	XGI-D24A	XGI-D24B	XGI-D28A	XGI-D28B	XGI-A12A	XGI-A21A	XGI-A21C	
Input point	8	16		32		64		16	8	8	
Rated input voltage	DC24V							AC100-120V	Free voltage	DC100/240V	
Rated input current	4mA							8mA	17mA	17mA	
ON voltage/current	19V or more / 3mA or less							AC80V or more / 5mA or less	AC130V or more / 10mA or less	AC80V or more / 5mA or less	
OFF voltage/current	DC11V or more / 1.7mA or less							AC80V or more / 5mA or less	AC40V or more / 2mA or less	AC30V or more / 1mA or less	
Response	Off→On	1ms/5ms/10ms/20ms/70ms (set by CPU parameter) Initial value: 3ms							15mA or less		
	On→Off	1ms/5ms/10ms/20ms/70ms (set by CPU parameter) Initial value: 3ms							25mA or less		
Common (COM)	8 points/COM	16 points/COM		32 points/COM				16 points/COM	8 points/COM	1 points/COM	
Insulation method	Photocoupler							Photocoupler			
Current consumption (mA)	20	30		50		60		30	20	20	
Weight (Kg)	0.1	0.12		0.1		0.15		0.13	0.13	0.13	

Output module specifications

Item	Relay			Transistor						Triac	
Type	XGQ-RY1A	XGQ-RY2A	XGQ-RY2B	XGQ-TR1C	XGQ-TR2A	XGQ-TR2B	XGQ-TR4A	XGQ-TR4B	XGQ-TR8A	XGQ-TR8B	XGQ-SS2A
Output point	8	16		8	16		32		64		16
Rated input voltage	DC12/24V, AC110/220V			DC12/24V						AC110/220V	
Rated input current	1 Point	2A		2A	0.5A		0.1A				0.6A
	Common	5A		0.1A	4A		2A				4A
Response time	Off→On	10ms or less		3ms or less	1ms or less						1ms or less
	On→Off	12ms or less		10ms or less	1ms or less						0.5cycle +1ms or less
Common (COM)	1 point/COM	16 points/COM		1 points/COM	32 points/COM						16 points/COM
Insulation method	Relay			Photocoupler							
Current consumption (mA)	260	500		100	70		130		230		300
Weight (Kg)	0.13	0.17	0.19	0.11	0.11		0.1		0.15		0.2
Surge killer	-		Varistor	Zener diode						Varistor	
External power supply	-			DC12/24V			DC				-

Note) B1, B2 of 32, 62 points terminal [connector] are shorted inside of the product.

Wiring diagram for input modules

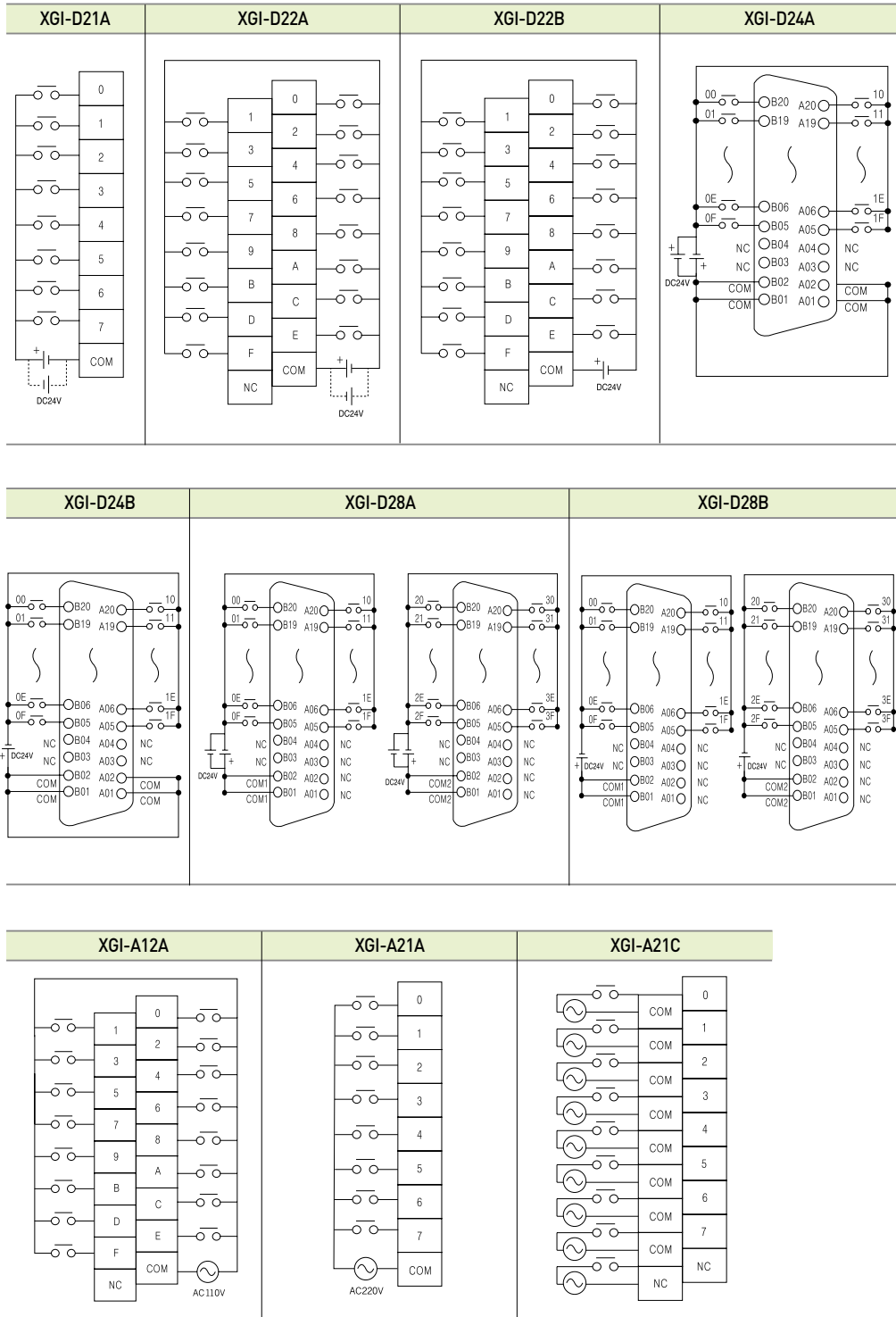

Wiring diagram for output modules

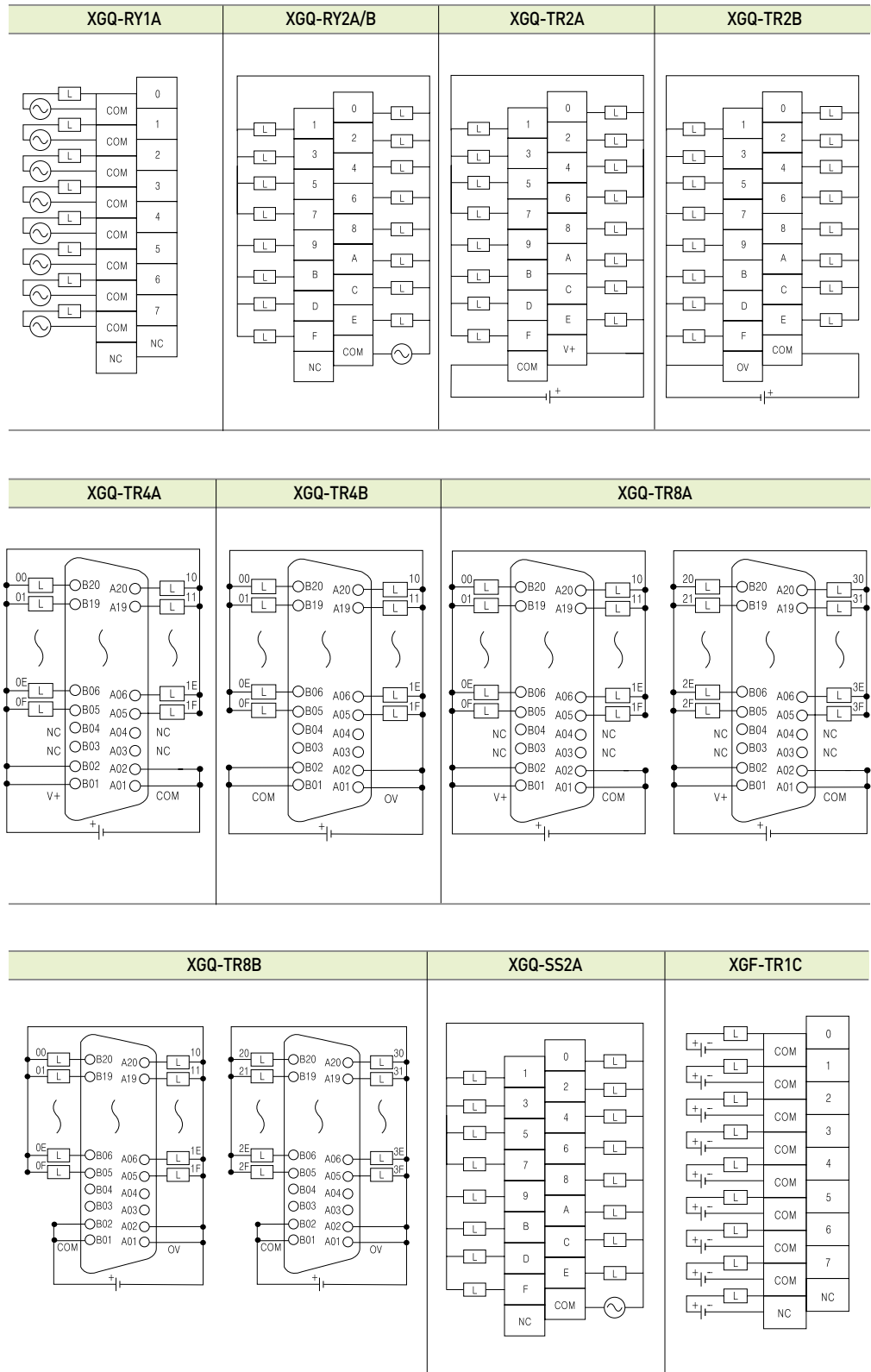



Diagnostic Digital Input Module(XGI-D21D)

- Diagnostic Digital Input module receives and processes DC 24V input signal. It has a wire break detection function of each input signal.
- Input signal and wire break detection signal are displayed on the device of the CPU module, it can be used in the PLC program.

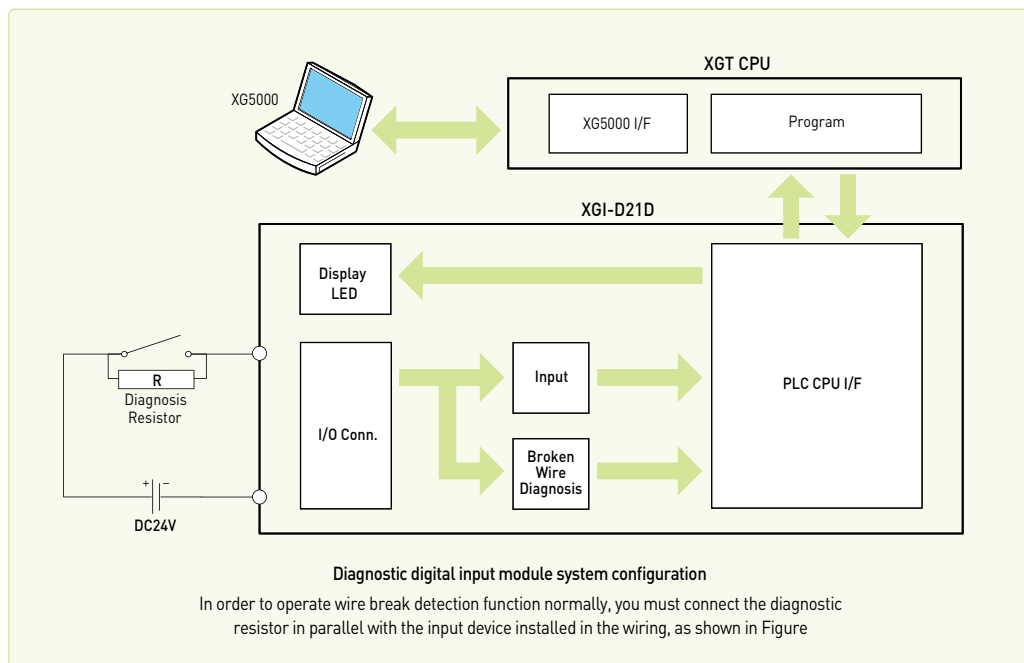

Specifications

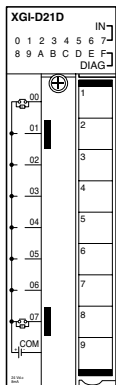

- IN: Input status(0-7)
- On: Input On
 - Off: Input Off
- DIAG: Diagnosis status(8-F)
- On: broken wire occurs
 - Off: Normal state

Item	Specifications				
Input point	8 points				
Insulation method	Photo coupler insulation				
Rated input voltage / current	DC24V / Approx. 8mA				
Voltage range	DC20.4~28.8V (5% and lower ripple rate)				
On voltage / On current	19V and higher / 5.2mA and higher				
Off voltage / On current	11V and lower / 4.7mA and lower				
Response time (Input filter)	<table border="1"> <tr> <td>Off→On</td> <td>1ms/3ms/5ms/10ms/20ms/70ms/100ms, Initial value:3ms</td> </tr> <tr> <td>On→Off</td> <td>1ms/3ms/5ms/10ms/20ms/70ms/100ms, Initial value:3ms</td> </tr> </table>	Off→On	1ms/3ms/5ms/10ms/20ms/70ms/100ms, Initial value:3ms	On→Off	1ms/3ms/5ms/10ms/20ms/70ms/100ms, Initial value:3ms
Off→On	1ms/3ms/5ms/10ms/20ms/70ms/100ms, Initial value:3ms				
On→Off	1ms/3ms/5ms/10ms/20ms/70ms/100ms, Initial value:3ms				
Insulation withstand voltage	DC 500V				
Insulation resistance	10 Ω and higher by Insulation ohmmeter				
Diagnosis function	Wire break detection				
Common method	8 point / 1COM				
Suitable cable size	Stranded cable between 0.3-0.75mm ² (2.8mm and smaller outer dia.)				
Suitable clamped terminal	R1.25-3 (Sleeve built-in clamped terminal is not available)				
Current consumption(mA)	60mA				
Operation display	LED On with input On LED On during wire break				
External connection method	9 point Terminal strip connector (M3 X 6 screws)				
Weight	95g				



Diagnostic Digital Output Module(XGQ-RY1D)

- Diagnostic digital output module outputs output signal via the relay to the outside. It has a diagnostic function of the internal signal and wire break detection for each output signal.
- Diagnostic signals are displayed on the device of the CPU module, it can be used in the PLC program.

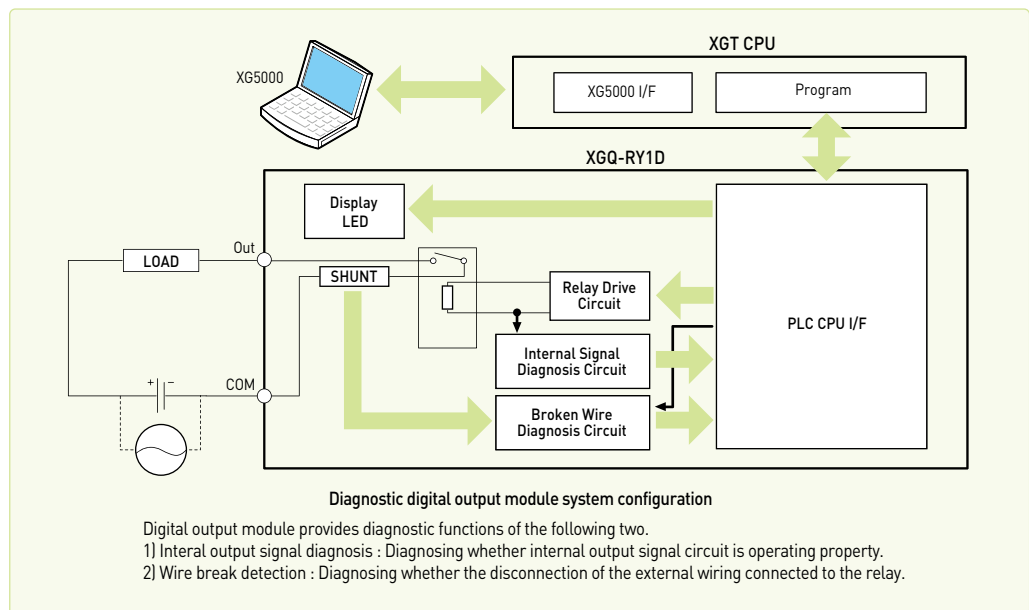

Specifications

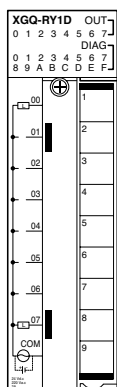

- OUT: Output status (0 ~ 7)**
- On: Relay output On
 - Off: Relay output Off
- DIAG : Diagnosis status**
- Internal output signal diagnosis (0 ~ 7)
- On: Internal output signal fail
 - Off: Normal state
- Wire break detection(8~F)
- On: broken wire occurs
 - Off: Normal state

Item	Specifications	
Output point	8 points	
Insulation method	Relay insulation Photo coupler insulation	
Rated load voltage	DC24V (resistance load) / AC220V (COS φ = 1)	
Rated load current	1 point: 2A Common: 5A	
Min. load voltage / current	DC5V / 1mA	
Max. load voltage / current	AC250V, DC125V / 2A	
Leakage current at Off	0.1mA (AC220V, 60Hz)	
Max. switching frequency	1,800 times/hour	
Surge killer	None	
Life	Mechanical	20 million and more times
	Electrical	Rated load voltage/current 100 thousand and more times
		AC200V / 1.5A, AC240V / 1A (COS φ = 0.7) 100 thousand and more times
		AC200V / 1A, AC240V / 0.5A (COS φ = 0.35) 100 thousand and more times
Response time	DC24V / 1A, DC100V / 0.1A (L / R = 7ms) 100 thousand and more times	
	Off → On: 10ms and lower On → Off: 12ms and lower	
Diagnosis function	Wire break detection Internal output signal diagnosis	
Common method	8 point/1COM	
Current consumption(mA)	Max. 400mA	
Operation display	LED On with output On LED On during wire break LED On when the internal output signal fail	
External connection method	9 point Terminal strip connector (M3 X 6 screws)	
Weight	145g	

Input/output mixed Type (XGH-DT4A)

Input		Output			
Input points	16 points	Input points	16 points		
Insulation method	Photo coupler	Insulation method	Photo coupler		
Rated input voltage	DC24V	Rated input voltage	DC12/24V		
Rated input current	4mA	Rated input current	DC10.2-26.4V		
Input voltage range	DC20.4-28.8V	Input voltage range	0.1A/point, 1.6A/COM		
Insulation pressure	AC560Vrms / 3Cycle	Insulation pressure	0.1mA or less		
On voltage/current	DC19V or more / 3mA or more	On voltage/current	0.7A/10ms or less		
Off voltage/current	DC11V or more / 1.7mA or more	Off voltage/current	Zener diode		
Input resistance	5.6k Ω	Input resistance	DC 0.2V or less		
Response	Off \rightarrow On	1ms/3ms/5ms/10ms/20ms/70ms/100ms (Setting by CPU parameter) Initial value: 3ms	Response	Off \rightarrow On	1ms or less
		1ms/3ms/5ms/10ms/20ms/70ms/100ms (Setting by CPU parameter) Initial value: 3ms		On \rightarrow Off	1ms or less (rated load, resistance load)
	On \rightarrow Off	1ms/3ms/5ms/10ms/20ms/70ms/100ms (Setting by CPU parameter) Initial value: 3ms	Response	On \rightarrow Off	1ms or less (rated load, resistance load)
		1ms/3ms/5ms/10ms/20ms/70ms/100ms (Setting by CPU parameter) Initial value: 3ms		On \rightarrow Off	1ms or less (rated load, resistance load)
Common (COM)	16 points/COM				
Operation display	LED lighting when output is ON				
Internal current consumption	100mA				
External connection	40-point connector				
Weight (kg)	0.1				

Wiring diagram for mixed type

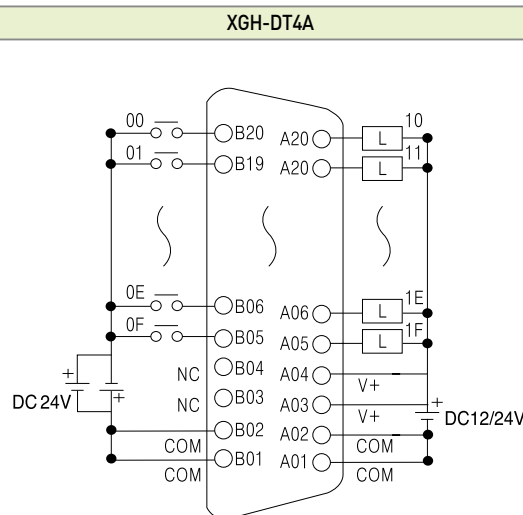

NOTE] Input address for XGK CPU is P00-P0F and Output address is P10-P1F when it is installed on the slot 0.
 Input address for XGI CPU is %IX0.0.0-%IX0.0.15 and Output address is %QX0.0.16-%QX0.0.31

Precaution during installation of I/O module

- XGT has 2 kinds of digital input type: Current sink input, Current source input. For DC input module has different wiring depending on the input type, digital input type should be selected with consideration about connected input device.
- Max. number of simultaneous input point differs according to the module type. Therefore, review specification of input module before its application.
- Use an interrupt module when a response of high-speed input is demanded. But only one interrupt module can be installed per CPU module.
- If switching frequency is high or inductive switching load is used, the lifespan of relay output module will be reduced. Therefore, it is recommended to use transistor output module or triac output module.
- When driving an inductive load with output module, set the maximum switching frequency as 'ON' for 1 second and 'OFF' for 1 second.
- When using counter or timer with DC/DC converter, it is possible to have inrush current which cause a break down. Therefore to reduce an effect of inrush current, connect resistor or inductor to load or use the module whose max. load current is high.

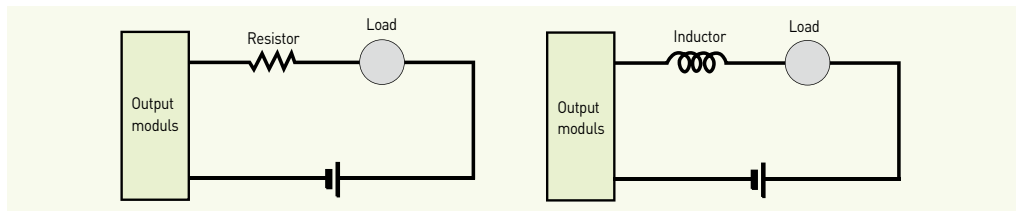

- Fuse of output module is not exchangeable to prevent a damage of external wiring when output module has a short-circuit.
- The number of simultaneous 'ON' points varies depending on input voltage, ambient temperature. Refer to the specification of input module.
- The following graph presents the relay lifespan of relay output module. It shows the maximum lifespan of relay which is used in the relay output.

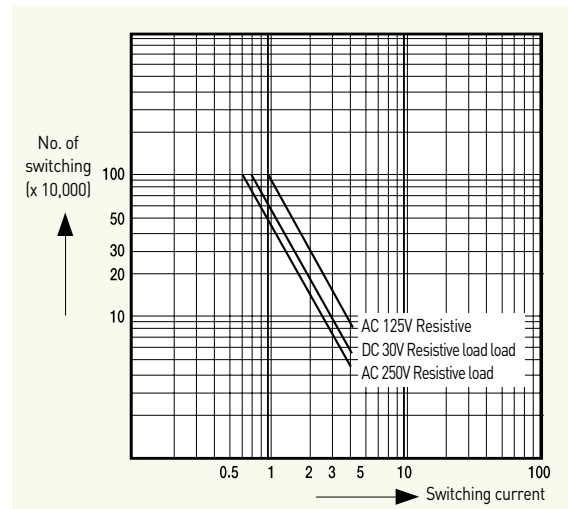

- Compressed terminal attaching sleeve cannot be mounted to XGT terminal block. The following picture shows appropriate compressed terminals for terminal block.

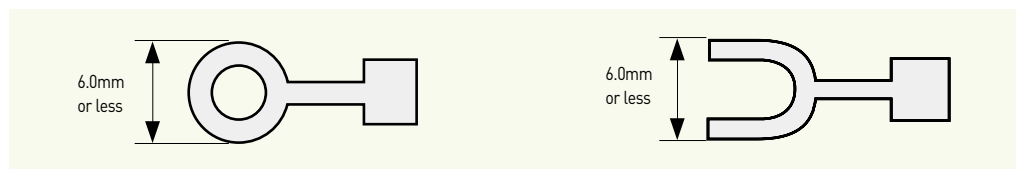

- Use 0.3-0.75mm twisted pair, below 2.8mm thickness cable for connecting to terminal block.
- Be careful when choosing and using the cable since the permissible current differs according to the insulation thickness.
- Joint torque of fixed screw and terminal block screw of the module needs to be within the range in the following table.

Joint	Joint torque range
I/O module terminal block screw (M3)	42-58 N·cm
I/O module terminal block fixed screw (M3)	68-89 N·cm

- Thermal protector is built in transistor module. Thermal protector is a function that protects PLC from an overload and overheating.